

---

TECHNICAL MANUAL  
OPERATOR'S MANUAL

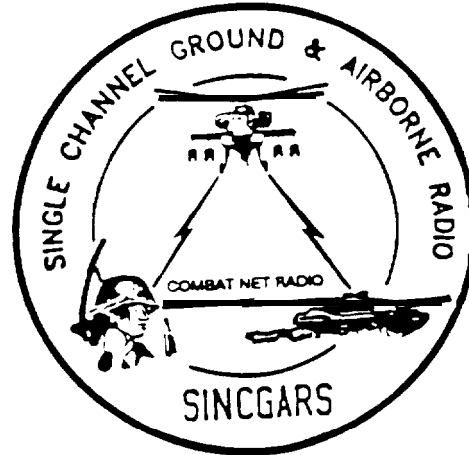

**SINGARS GROUND COMBAT  
NET RADIO, ICOM**

**MANPACK RADIO**

AN/PRC-119A/D/F (NSN 5820-01-267-9482) (EIC: L2Q)

**SHORT RANGE VEHICULAR RADIO**

AN/VRC-87A/D/F (NSN 5820-01-267-9480) (EIC: L22)

**SHORT RANGE VEHICULAR RADIO WITH SINGLE RADIO MOUNT**

AN/V/R/C-87C (NSN 5820-01-304-2045) (EIC:GDC)

**SHORT RANGE VEHICULAR RADIO WITH DISMOUNT**

AN/VRC-88A/D/F (NSN 5820-01-267-9481) (EIC: L23)

**SHORT RANGE/LONG RANGE VEHICULAR RADIO**

AN/VRC-89A/D/F (NSN 5820-01-267-9479) (EIC: L24)

**LONG RANGE VEHICULAR RADIO**

AN/VRC-90A/D/F (NSN 5820-01-268-5105) (EIC: L25)

**SHORT RANGE/LONG RANGE VEHICULAR RADIO WITH DISMOUNT**

AN/VRC-91A/D/F (NSN 5820-01-267-9478) (EIC: L26)

**SHORT RANGE/LONG RANGE VEHICULAR RADIO**

AN/VRC-92A/D/F (NSN 5820-01-267-9477) (EIC: L27)

**USED WITH**

**AUTOMATED NET CONTROL DEVICE (ANCD) (AN/CYZ-10)  
PRECISION LIGHTWEIGHT GPS RECEIVER (PLGR) (AN/PSN-11)  
SECURE TELEPHONE UNIT (STU)  
FREQUENCY HOPPING MULTIPLEXER (FHMUX)**

Approved for public release; distribution is unlimited.

---

HEADQUARTERS, DEPARTMENT OF THE ARMY

1 DECEMBER 1998



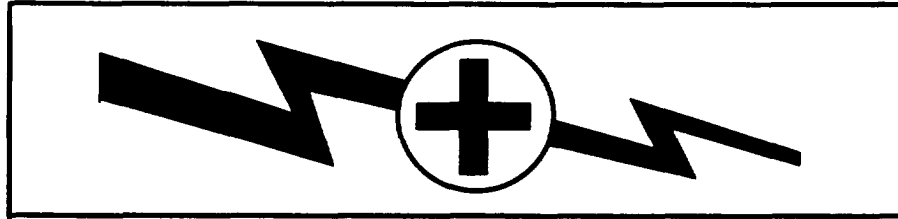

## **5** SAFETY STEPS TO FOLLOW IF SOMEONE IS THE VICTIM OF ELECTRICAL SHOCK.

---

---

- 1** DO NOT TRY TO PULL OR GRAB THE INDIVIDUAL.
- 2** IF POSSIBLE, TURN OFF THE ELECTRICAL POWER.
- 3** IF YOU CANNOT TURN OFF THE ELECTRICAL POWER PULL, PUSH, OR LIFT THE PERSON TO SAFETY USING A DRY WOODEN POLE OR A DRY ROPE OR SOME OTHER INSULATION MATERIAL.
- 4** SEND FOR HELP AS SOON AS POSSIBLE.
- 5** AFTER THE INJURED PERSON IS FREE OF CONTACT WITH THE SOURCE OF ELECTRICAL SHOCK, MOVE THE PERSON A SHORT DISTANCE AWAY AND IMMEDIATELY START ARTIFICIAL RESUSCITATION.

**WARNING**

A lithium-sulfur dioxide (Li-SO<sub>2</sub>) battery used with Battery Box, CY-8523 series contains pressurized sulfur dioxide (SO<sub>2</sub>) gas (rotten egg smell). The gas is toxic, and the battery **MUST NOT** be abused in any way which may cause the battery to rupture.

**DO NOT** heat, short circuit, crush, puncture, mutilate, or disassemble the battery.

**DO NOT USE** any battery which shows signs of damage, such as bulging, swelling, disfigurement, brown liquid in the plastic wrap, a swollen plastic wrap, etc.

**DO NOT** test Li-SO<sub>2</sub> batteries for capacity, except as authorized.

**DO NOT** recharge Li-SO<sub>2</sub> batteries.

**DO NOT** use water to extinguish Li-SO<sub>2</sub> battery fires.

If the battery compartment becomes hot to the touch, if you hear a hissing sound (i.e., battery venting), or if you smell irritating sulfur dioxide gas (rotten egg smell), **IMMEDIATELY TURN OFF** the equipment. Remove the equipment to a well ventilated area or leave the area.

**DO NOT** use a Halon type fire extinguisher on a lithium battery fire.

In the event of a fire near a lithium battery(ies), rapid cooling of the battery(ies) is important. Use a carbon dioxide (CO<sub>2</sub>) extinguisher.

**DO NOT** store lithium batteries with other hazardous materials and keep them away from open flame or heat.

**MANPACK LONG ANTENNA SAFETY PRECAUTIONS****WARNING****DEATH OR SERIOUS INJURY CAN OCCUR IF THE ANTENNA COMES INTO CONTACT WITH OVERHEAD POWER LINES**

Never fully extend the long antenna directly under power lines. If you must fully extend the long antenna near power lines, power line poles or towers, or buildings with overhead power line connections, never come closer than two times the antenna height from the base of the power line, pole tower or building.

Stop before you get close to the power line and check for clearance before passing. If needed, either carefully tie down the antenna or remove the antenna to make sure that you can safely pass under the power line.

When mission permits, use the short manpack antenna during operations on the move. If you must use the long antenna on the move, never pass under power lines if there is any doubt about overhead clearance.

For additional safety information, refer to TB-43-0129. "Safety Requirements for Use of Antenna and Mast Equipment".

**VEHICULAR ANTENNA SAFETY PRECAUTIONS****WARNING****DEATH OR SERIOUS INJURY CAN OCCUR IF THE ANTENNA COMES INTO CONTACT WITH OVERHEAD POWER LINES**

Do not stop your vehicle under power lines.

When mobile, never pass under power lines if there is any doubt about overhead clearance.

If you are not sure that an antenna on your vehicle will clear a power line, stop before you get close to the power line and either carefully tie down the antenna or, if necessary, remove the antenna to make sure that you can safely drive under the power line.

During cross-country operations, do not allow anyone to stick an arm, leg, or weapon over the sides of the vehicle. If your antenna accidentally touches a power line, individuals who are in contact with vegetation or the ground could suffer death or severe injury.

For additional safety information, refer to TB-43-0129, "Safety Requirements for Use of Antenna and Mast Equipment".

**THIS PAGE INTENTIONALLY  
BLANK.**

TECHNICAL MANUAL  
No. 11-5820-890-10-8

HEADQUARTERS  
DEPARTMENT OF THE ARMY  
Washington, DC, 1 DECEMBER 1998

## **SINGGARS GROUND COMBAT NET RADIO, ICOM**

### **MANPACK RADIO**

AN/PRC-119A/D/F (NSN 5820-01-267-9482) (EIC: L2Q)

### **SHORT RANGE VEHICULAR RADIO**

AN/VRC-87A/D/F (NSN 5820-01-267-9480) (EIC: L22)

### **SHORT RANGE VEHICULAR RADIO WITH SINGLE RADIO MOUNT**

AN/VRC-87C (NSN 5820-01-304-2045) (EIC: GDC)

### **SHORT RANGE VEHICULAR RADIO WITH DISMOUNT**

AN/VRC-88A/D/F (NSN 5820-01-267-9481) (EIC: L23)

### **SHORT RANGE/LONG RANGE VEHICULAR RADIO**

AN/VRC-89A/D/F (NSN 5820-01-267-9479) (EIC: L24)

### **LONG RANGE VEHICULAR RADIO**

AN/VRC-90A/D/F (NSN 5820-01-268-5105) (EIC: L25)

### **SHORT RANGE/LONG RANGE VEHICULAR RADIO WITH DISMOUNT**

AN/VRC-91A/D/F (NSN 5820-01-267-9478) (EIC: L26)

### **SHORT RANGE/LONG RANGE VEHICULAR RADIO**

A N/VRC-92A/D/F (NSN 5820-01-267-9477) (EIC: L27)

### **USED WITH**

**AUTOMATED NET CONTROL DEVICE (ANCD)(AN/CYZ- 10)  
PRECISION LIGHTWEIGHT GPS RECEIVER (PLGR) (AN/PSN-11)  
SECURE TELEPHONE UNIT (STU)  
FREQUENCY HOPPING MUTIPLXER (FHMUX)**

\* This manual supersedes TM 11-5820-890-10-8, dated 28 February 1995.

## TABLE OF CONTENTS

<u>CHAP</u>	<u>PARA</u>	<u>SUBJECT</u>	<u>PAGE</u>
<b>1</b>		<b>INTRODUCTION .....</b>	<b>1-1</b>
	1.1	Purpose .....	1-1
	1.2	Scope .....	1-1
	1.3	General Information .....	1-2
<b>2</b>		<b>SINGARS RADIOS AND COMPONENTS .....</b>	<b>2-1</b>
	2.1	SINGARS Receiver-Transmitters (RT) (RT -1523 Series).....	2-2
	2.2	Technical .....	2-8
	2.3	Manpack (MP) Radios .....	2-14
	2.4	Battery Requirements .....	2-17
	2.5	Vehicular (Veh) Radios .....	2-19
	2.6	Single Radio Mount (SRM) Radio .....	2-32
	2.7	Remote Control Unit (RCU) .....	2-35
	2.8	Control Monitor (C-M) .....	2-37
	2.9	Loudspeaker (LS-671) .....	2-39
<b>3</b>		<b>ASSOCIATED EQUIPMENT .....</b>	<b>3-1</b>
	3.1	Automated Net Control Device (ANCD) (AN/CYZ-10) .....	3-2
	3.2	Precision Lightweight GPS Receiver (PLGR) (AN/PSN - 11) .....	3-4
	3.3	Frequency Hopping Multiplexer (FHMUX) (TD-1456/VRC) .....	3-5
	3.4	Secure Telephone Unit (STU) .....	3-8
	3.5	Vehicular Intercommunications Set (VIC) (AN/VIC- 1).....	3-10
	3.6	Handheld Remote Control Radio Device (HRCRD) .....	3-12
<b>4</b>		<b>PRINCIPLES OF OPERATION .....</b>	<b>4-1</b>
	4.1	Secure (Cipher Text) (CT) Communications .....	4-2
	4.2	Single Channel (SC) Communications .....	4-4
	4.3	Frequency Hopping (FH) Communications .....	4-6
	4.4	Use of Julian Date and GPS Zulu Time .....	4-10
	4.5	Net Opening .....	4-13
	4.6	Late Net Entry .....	4-18
	4.7	Periodic Updating .....	4-22
	4.8	Electronic Updating .....	4-24
	4.9	Retransmission (RXMT) Operations .....	4-28
	4.10	Antennas .....	4-32
	4.11	Remoting Capabilities .....	4-34
	4.12	Net Management .....	4-46



<u>CHAP</u>	<u>PARA</u>	<u>SUBJECT</u>	<u>PAGE</u>
<b>5</b>		<b>OPERATOR TASKS .....</b>	<b>5-1</b>
	5.1	General .....	5-2
	5.2	Start-Up Procedure .....	5-3
	5.3	Operator Controls .....	5-5
	5.4	Primary Operator/Preparation Tasks .....	5-28
	5.5	Special Operator Tasks .....	5-42
	5.6	Special Operator Tasks (SIP/ASIP) .....	5-62
	5.7	Other Operator Procedures .....	5-64
<b>6</b>		<b>NET CONTROL STATION (NCS) TASKS .....</b>	<b>6-1</b>
	6.1	General .....	6-2
	6.2	NCS Responsibilities .....	6-3
	6.3	Primary NCS Tasks .....	6-6
	6.4	Special NCS Tasks .....	6-18
<b>7</b>		<b>SINGGARS ASSOCIATED TASKS .....</b>	<b>7-1</b>
	7.1	General .....	7-2
	7.2	Precision Lightweight GPS Receiver (PLGR) Tasks .....	7-3
	7.3	Secure Telephone Unit (STU) .....	7-11
	7.4	Frequency Hopping Multiplexer (FHMUX) .....	7-17
<b>a</b>		<b>OPERATOR MAINTENANCE .....</b>	<b>8-1</b>
	8.1	SINGGARS Radio Maintenance .....	8-1
	8.2	Associated Equipment .....	8-13
	8.3	Battery Requirements .....	8-25
<b>APPENDIX</b>			
	<b>A</b>	.....	<b>A-1</b>
	<b>B</b>	.....	<b>B-1</b>
	<b>C</b>	.....	<b>C-1</b>
	<b>E</b>	.....	<b>E-1</b>
<b>INDEX .....</b>			<b>Index-1</b>

## HOW TO USE YOUR MANUAL

### **COVER**

Information that you will use most often is boxed on the rear cover as well as in the Table of Contents. The boxed information found on the rear cover is thumb-indexed with edge marks so you can quickly refer to that information.

### **TABLE OF CONTENTS**

Refer to the Table of Contents to find out where information can be found. The Table of Contents lists each chapter and major paragraph, showing subject, paragraph, and page numbers.

### **CHAPTER CONTENTS**

For ease of reference, each chapter begins with a chapter table of contents showing the major paragraphs and sub-paragraphs contained in that chapter. Paragraph and page numbers are also provided.

### **SUBJECT INDEX**

A subject matter index may be found at the rear of the manual. Subjects are listed alphabetically by page number. The index is a good place to start if you are looking for a specific item of information.

### **ABBREVIATIONS**

For sake of brevity, this manual makes generous use of abbreviations. Abbreviations are identified with their complete meaning at first use and frequently thereafter. If you need the meaning of an abbreviation, it may be found in the alphabetical listing of abbreviations found in Appendix E at the rear of the manual.

### **GLOSSARY**

You may refer to the Glossary, also found in Appendix E, to find the meaning of unfamiliar terms.

### **NOMENCLATURE CROSS- REFERENCE LIST**

Although you will most frequently use common names for items of SINCGARS equipment, if you need to know the official nomenclature for an item it may be found in the Nomenclature Cross-Reference List, in Appendix E.

### **POCKET GUIDES**

Operator's and NCS Pocket Guides supplement this manual with information you can carry in your pocket. Use your pocket guide as a handy reference that prevents you from having to memorize task performance procedures.

# CHAPTER 1

## INTRODUCTION

<b>IN THIS CHAPTER:</b>	
1.1	<b>PURPOSE</b> ..... 1-1
1.2	<b>SCOPE</b> ..... 1-1
1.3	<b>GENERAL INFORMATION</b> ..... 1-2
a.	Maintenance Forms, Records, and Reports ..... 1-2
b.	Consolidated index of Army Publications and Blank Forms . . . 1-3
c.	Reporting Equipment Improvement Recommendations (EIR) ..... 1-3
d.	Reporting Errors and Recommending Improvements . . . . . 1-3
e.	Hand Receipt (-HR) Manuals ..... 1-3
f.	Security Classification and Marking ..... 1-3

**1.1. PURPOSE**

**READY REFERENCE**

Provide you with a ready reference when you need information regarding SINCGARS (Single Channel Ground & Airborne Radios) radios, their components, and associated equipment which is frequently employed in conjunction with SINCGARS radios. For example, this Manual contains official nomenclatures, common names, National Stock Numbers, part numbers, and unit authorizations.

**EASE OF USE**

Offer essential guidance regarding the employment and operation of SINCGARS that is easy to locate and readily understandable.

**BACK-UP**

Augment the operator and net control station (NCS) pocket guides with additional guidance and information as appropriate.

**1.2. SCOPE**

**EQUIPMENT**

This SINCGARS Operator's Manual cover capabilities and general specifications of SINCGARS Ground ICOM Radios using receiver-transmitter (RT) versions RT-1523, RT-1523A, RT-1523B, RT-1523C, RT-1523D, and RT-1523E. It covers both Manpack and Vehicular Radios, their principal components, Single Radio Mounts, Control Monitors, and remote control units (RCU). SINCGARS associated items of equipment addressed in this manual include the Automated Net Control Device (ANCD), Precision Lightweight GPS Receiver (PLGR), Frequency Hopping Multiplexer (FHMUX), Vehicular Intercommunications Set (VIC-1), and Secure Telephone Unit (STU) when used to transmit classified data from one location to another.

**OPERATIONS**

The Principles of Operation chapter covers how SINCGARS radios and associated equipment are employed to accomplish various communications requirements during unit mission operations. Some specific subjects addressed are single channel communications, frequency hopping nets, use of Julian Date and GPS Zulu time, net openings and late net entry methods, updating procedures, retransmission operations, use of antennas, remote control operations, and frequency management.

**TASKS**

Specific tasks covered in terms of sequential procedures are Operator Primary and Special, NCS Primary and Special, plus PLGR, FHMUX, and STU Transfer tasks. ANCD tasks are addressed as integral parts of Operator and NCS tasks.

**MAINTENANCE**

Operator level maintenance pertaining to SINCGARS radios is treated in the form of Preventive Maintenance Checks and Services (PMCS). Essential operator maintenance requirements for associated equipment is covered briefly and references are cited for each.

**BATTERIES**

Because of the critical Importance of batteries to the operation of SINCGARS radios and associated equipment, a Battery Requirements section provides general guidance regarding the number of hours of service that may be expected of various types of batteries under differing operational conditions.

**1.3. GENERAL INFORMATION**

**1.3a. Maintenance Forms, Records And Reports**

**DA Pam 738-750**

**Reports of Maintenance and Unsatisfactory Equipment.**

Department of the Army forms and procedures used for equipment maintenance will be those prescribed by DA Pam 738-750, as contained in Maintenance Management Update.

**SF 364 (ROD)**

**Reporting of Item and Packaging Discrepancies.**

Fill out and forward SF 364 (Report of Discrepancy (ROD) as prescribed in AR 735-11-2/DLAR 4140.55/SECNAVINST 4355.18/AFR 400-54/MCO 4430.3J.

**SF 361 (TDR)**

**Transportation Discrepancy Report (TDR) (SF 361).**

Fill out and forward Transportation Discrepancy Report (TDR) (SF 361) as prescribed in AR 55-38/NAVSUPINST 4610.33C/AFR 75-18/MCO P4610. 19D/DLAR 4500.15.

### 1.3b. Consolidated Index Of Army Publications And Blank Forms

DA Pam 25-30

Refer to the latest issue of DA Pam 25-30 to determine whether there are new editions, changes or additional publications pertaining to the equipment.

### 1.3c. Reporting Equipment Improvement Recommendations (EIR)

SF 368 (EIR)

If your radio or associated equipment needs improvement, let us know. Send us an EIR. You, the user, are the only one who can tell us what you don't like about your equipment. Let us know why you don't like the design or performance. Put it on an SF 368 (Product Quality Deficiency Report), if you can obtain this form. Otherwise, use regular paper for your report. Our interest is in what you have to tell us, and you will receive a reply. Mail your report to: **COMMANDER, U.S. ARMY CECOM, ATTN: AMSEL-ED-PH, FORT MONMOUTH, NJ 07703 - 5007.**

### 1.3d. Reporting Errors And Recommending Improvements

DA Form 2028

You can help improve this manual. If you find any mistakes or if you know of a way to improve the procedures, please let us know. Mail your letter, DA Form 2028 (Recommended Changes to Publications and Blank Forms), or DA Form 2028-2 located in the back of this manual directly to:

**COMMANDER, U.S. ARMY CECOM,  
ATTN: AMSEL-LC-LEO-D-SFO,  
FORT MONMOUTH, NJ 07703-5007** or electronically at [www.monmouth.army.mil/cecom/lrc/pubs/2028.html](http://www.monmouth.army.mil/cecom/lrc/pubs/2028.html), fill out the Online 2028 form and submit it for a faster response.

### 1.3e. Hand Receipt (-HR) Manuals

TM 10-HR

This manual has a companion document with a TM number followed by "-HR" (Hand Receipt). The TM 11-5820-890-10-HR consists of preprinted hand receipts (DA Form 2062) that list end item related equipment (i.e., COEI, BII, and AAL) you must account for. As an aid to property accountability, additional -HR manuals may be requisitioned from supply channels.

### 1.3f. Security Classification And Marking

TB 380-41-5

The receiver-transmitter (RT) of the SINCGARS ICOM ground radio, the remote control unit (RCU), and the Automated Net Control Device (ANCD) are designated as Controlled Cryptographic Items (CCI). Handle in accordance with TB 380-41-5.

**THIS PAGE INTENTIONALLY  
BLANK.**

## CHAPTER 2

# SINGGARS RADIOS AND COMPONENTS

**IN THIS CHAPTER:**

<b>2.1</b>	<b>SINGGARS Receiver-Transmitters (RT) (RT-1523 Series)</b> .....	<b>2-2</b>
	a. RT Capabilities .....	2-2
	b. Transmitter Characteristics .....	2-3
	c. Receiver Characteristics .....	2-4
	d. RT Model Differences (Distinguishing Features) .....	2-4
<b>2.2</b>	<b>TECHNICAL</b> .....	<b>2-8</b>
	a. SIP/ASIP Receiver-Transmitter (RT) .....	2-8
	b. SIP/ASIP RT Keypad .....	2-8
	c. SIP/ASIP VAA .....	2-9
	d. Connectors SIP RT .....	2-10
	e. Connectors, ASIP RT .....	2-11
	f. RT Messages .....	2-12
	g. RT Physical Data .....	2-13
	h. Common Connections .....	2-13
<b>2.3</b>	<b>MANPACK (MP) RADIOS</b> .....	<b>2-14</b>
	a. MPGeneral .....	2-14
	b. MP Radio Components .....	2-14
	c. MP Radio Physical Data .....	2-15
	d. MP Radio Performance Data .....	2-16
<b>2.4</b>	<b>BATTERY REQUIREMENTS</b> .....	<b>2-17</b>
	a. Power Source .....	2-17
	b. Main Power .....	2-17
	c. HUB.. .....	2-17
	d. Manpack Radio .....	2-17
	e. RCU(RT) .....	2-18
	f. Hold-Up Battery .....	2-18
<b>2.5</b>	<b>VEHICULAR (VEH) RADIOS</b> .....	<b>2-19</b>
	a. General .....	2-19
	b. Short Range (SR) Radio Components (AN/VRC-87A/D/F) .....	2-21
	c. Short Range Radio with Dismount (SR-D) Components (AN/VRC-88A/D/F) .....	2-22
	d. Long Range (LR) Radio Components (AN/VRC-90A/D/F) .....	2-22
	e. Short Range/Long Range Radio Components (AN/VRC-89A/D/F) .....	2-23
	f. Short Range/Long Range Radio with Dismount Components (AN/VRC-91A/D/F) .....	2-24
	g. Long Range/Long Range Radio Components (AN/VRC-92A/D/F) .....	2-24
	h. VAA Connectors (A/B models) .....	2-25
	i. VAA Connectors (C/D models) .....	2-27
	j. Cabling .....	2-29
	k. Vehicular Radio Physical Data .....	2-30
	l. Vehicular Radio Performance Data .....	2-31

<b>2.6</b>	<b>SINGLE RADIO MOUNT RADIO (SRM)</b> .....	<b>2-32</b>
	a. SR Radio with SRM Components (AN/VRC-87C) .....	2-32
	b. SRM Radio Physical Data .....	2-33
	c. SRM Radio Performance Data .....	2-34
<b>2.7</b>	<b>CONTROL, RECEIVER-TRANSMITTER (RCU) (C-11561 (C)/U)</b> .....	<b>2-35</b>
	a. RCU Components .....	2-35
	b. RCU Physical Data .....	2-36
	c. RCU Performance Data .....	2-36
<b>2.8</b>	<b>CONTROL-MONITOR (CM) (C-11291/VRC OR C-11291A/VRC)</b> .....	<b>2-37</b>
	a. CM Components .....	2-37
	b. CM Physical Data .....	2-38
	c. CM Performance Data .....	2-38
<b>2.9</b>	<b>LOUDSPEAKER (LS-671)</b> .....	<b>2-39</b>
	a. LS-671 Components .....	2-39
	b. LS-671 Physical Data .....	2-39
	c. LS-671 Performance Data .....	2-40

## 2.1. SINGARS RECEIVER-TRANSMITTERS (RT) (RT-1523 SERIES)

### 2.1 a. RT Capabilities

<b>SINGLE CHANNEL</b>	Single channel (SC) frequency modulation (FM) operation in very high frequency (VHF) band of 30.000 to 87.975 Megahertz (MHz).
<b>FREQUENCY HOPPING</b>	Frequency hopping (FH) mode for electronic counter counter-measure (ECCM) operation.
<b>PRESET CHANNELS</b>	Preset channels: eight for SC mode and six for FH mode, each of which may be loaded with COMSEC and used in CT or PT mode.
<b>DIGITAL TUNING</b>	Quick, silent, precise, digital tuning.
<b>VISUAL DISPLAY</b>	Electronic visual displays provide for quick checks and prompts.
<b>SELF-TEST (BIT)</b>	Built-in test (BIT) provides self-test for fast checking of equipment condition.
<b>VOICE-DATA</b>	Voice or digital data communication. Provides data rates of 600, 1200, 2400, 4800, and 16,000 bits per second [BPS]; also provides enhanced data rates (1200N, 2400N, 4800N, 9600N, PCKT) RT- 1523C/D/E only; analog data interface AD1 and TACFIRE TF.
<b>FREQUENCIES</b>	2320 SC frequencies.
<b>COMSEC</b>	Provides cipher text (CT) communications with integrated COMSEC (ICOM) feature.



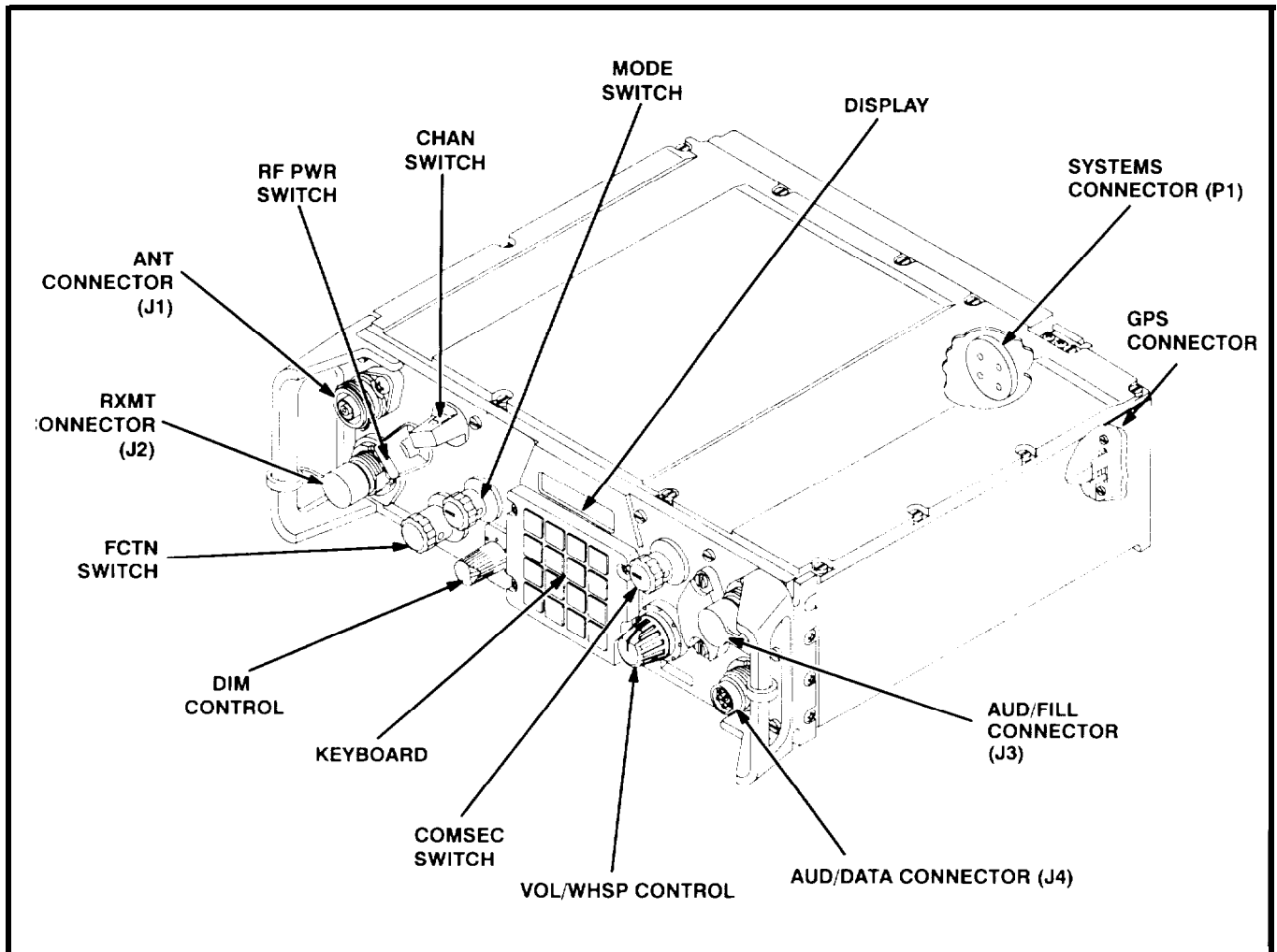

Figure 2-1. RECEIVER-TRANSMITTER (RT) (RT-1523 Series)

**2.1 b. Transmitter Characteristics**

**TYPICAL DUTY CYCLE**

“Typical duty cycle” is defined as nine minutes of receiving or monitoring for each one minute of transmission time; expressed as 9:1 duty cycle.

**MANPACK BATTERY**

With a 9:1 duty cycle, at 70 degrees F., a new manpack main power battery (BA-5590) has a service life of approximately 10-30 hours depending upon RT version and level of usage. (See Chapter 8 for additional data regarding service life expectancy of manpack batteries.)

**POWER DRAIN**

Manpack transmission maximum power draw is 3.25 amperes; vehicular radio is 6.25 amperes.

**CARRIER DEVIATION**

Carrier deviation (voice) is 6.5 Kilohertz (KHz) with audio input of 1.4 to 140 millivolts.

<b>MICROPHONE</b>	Microphone input impedance is 150 ohms.
<b>AUDIO</b>	Audio input (minimum) is 1.4 millivolts normal and 0.4 millivolts for whisper (WHSP).
<b>SQUELCH</b>	Squelch tone signal of 150 Hertz (Hz) is a part of all transmissions, except when FCTN is set to SQ OFF..

**2.1 c. Receiver Characteristics**

<b>SENSITIVITY</b>	Radio frequency (RF) signal sensitivity is 0.35 microvolt
<b>CHANNEL SPACING</b>	25 KHz.
<b>AUDIO</b>	Audio output impedance is 600 ohms (with handset at AUD/DATA or AUD/FILL).
<b>SQUELCH</b>	Receiver responds to 150 Hz tone with FCTN switch set to squelch on (SQ ON) or load (LD) when operating in SC mode.
<b>POWER DRAIN</b>	Manpack receiver power draw is 225 milliamperes. Vehicular receivers draw: 0.762 amp for short range radio; 1.094 amp for short range/long range radio; 0.942 amp for long range radio, and 1.524 amp for long range/long range radio.

**2.1d. RT Model Differences (Distinguishing Features)\***

<b>RT-1523:</b>	Control knobs are affixed with side- positioned Allen screws RT cover is affixed with slot-headed screws. Last two digits of net ID may be changed by operator. RT Mode switch is set to FH-M position to change net ID. Sync time is loaded into RT manually via the keypad or by electronic remote fill (ERF). Running self-test with COMSEC in PT results in display message of "FAIL 5." (Changing to CT clears message.) RT will accept ERF if sync time is less than +/- one hour different from net sync time.
-----------------	---

Figure 2-2. RT-1523 Features

**RT-1523A:**

Control knobs are affixed with top-positioned Phillips screws,  
 RT cover is affixed with Phillips screws,  
 All three digits of net ID may be changed by operator.  
 RT Mode switch may remain in FH position to change net ID.

Sync time may be loaded electronically from an Automated Net Control Device (ANCD), a Precision Lightweight GPS Receiver (PLGR), manually via the keypad, or by ERF.

Running self-test with COMSEC in PT results in display message of "GO CT" (Changing to CT clears message.)

RT will accept ERF if sync time is less than 100 days different from net sync time.

**Figure 2-3. RT-1523A Features**

**RT-15238:**

Control knobs are affixed with side-positioned Allen screws.  
 RT cover is affixed with slot-headed screws.  
 All three digits of net ID may be changed by operator.  
 RT Mode switch may remain in FH position to change net ID.

Sync time may be loaded electronically from an Automated Net Control Device (ANCD), a Precision Lightweight GPS Receiver (PLGR), manually via the keypad, or by ERF.

Running self-test with COMSEC in PT results in display message of "GO CT" (Changing to CT clears message.)

RT will accept ERF if sync time is less than 100 days different from net sync time.

**Figure 2-4. RT-1523B Features**

<b>RT-1523C:</b>	<p>Control knobs are affixed with side-positioned Allen screws.</p> <p>RT cover is affixed with Phillips-headed screws.</p> <p>All three digits of net ID may be changed by operator.</p> <p>RT Mode switch may remain in FH position to change net ID.</p> <p>Sync time may be loaded electronically from an Automated Net Control Device (ANCD), a Precision Lightweight GPS Receiver (PLGR), manually via the keypad, or by ERF</p> <p>Running self-test with COMSEC in PT results in display message of "GO CT" (Changing to CT clears message.)</p> <p>RT will accept ERF if sync time is less than <u>100 days</u> different from net sync time.</p> <p>New keypad with SIP features.</p> <p>GPS connector.</p>
------------------	---

**Figure 2-5. RT-1523C Features**

<b>RT-1523D:</b>	<p>Control knobs are affixed with side-positioned Phillips screws.</p> <p>RT cover is affixed with Phillips screws.</p> <p>All three digits of net ID may be changed by operator.</p> <p>RT Mode switch may remain in FH position to change net ID.</p> <p>Sync time may be loaded electronically from an Automated Net Control Device (ANCD), a Precision Lightweight GPS Receiver (PLGR), manually via the keypad, or by ERF</p> <p>Running self-test with COMSEC in PT results in display message of "GO CT" (Changing to CT clears message.)</p> <p>RT will accept ERF if sync time is less than <u>100 days</u> different from net sync time.</p> <p>New keypad with SIP features.</p> <p>GPS connector.</p>
------------------	---

**Figure 2-6. RT-1523D Features**

**RT-1523E:**

Reduced size and weight.

Internal battery.

Increased battery life.

Enhanced display (Backlight selectable).

Only one front panel switch.

Spare slots for future enhancements.

Enhanced self-test (BIT).

RT Mode switch may remain in FH position to change net ID.

All three digits of net ID may be changed by operator.

Sync time may be loaded electronically from an Automated Net Control Device (ANCD), a Precision Lightweight GPS Receiver (PLGR), manually via the keypad, or by ERF. RT will accept ERF if sync time is less than 100 days different from net sync time.

New keypad with SIP features.

GPS connector.

AUX connector for HRCRD/2-wire adapter.

**Figure 2-7. RT-1523E Features**

*\*Differences between RT models reflect manufacturer's options plus product improvements based on experience. They primarily affect radio performance and have minor impact on operator tasks and procedures.*

**12.2. TECHNICAL**

**2.2a. SIP/ASIP Receiver-Transmitter (RT)**

<b>Enhanced Data</b>	The SIP/ASIP RT offers enhanced data rates of 1200N, 2400N, 4800N, and 9600N BPS, where the “N” indicates new or enhanced rates. The advantages of these enhanced data rates are better accuracy, great speed, longer range, and improved forward error correction.
<b>New Data Modes</b>	Two new data modes are also provided: Packet (PCKT), which supports operations involving FBCB2 hardware and software, and RS-232 by which data messages can be sent from SIP/ASIP RT to SIP/ASIP RT using computers and commercial “Xmodem” communications software, a widely used file transfer protocol.
<b>RCU Function</b>	The SIP/ASIP RT can be used as a remote control unit by merely selecting the “RCU” option under the [RCU] key of the SIP/ASIP RT keypad. The RCU, C-11561, can still be used to remotely control a SIP/ASIP radio for voice and SINGARS data modes, but it cannot be used for enhanced data modes.
<b>GPS Time Loading</b>	A feature of the SIP/ASIP RT is the ability to load GPS time from an attached PLGR using the very simple procedure.
<b>Internal FSK Detector</b>	The SIP/ASIP RT contains an internal FSK detector circuit for use with the ‘AD1” and “TF” data rates. Use of a special CX-13808/U DMD interface cable is no longer necessary. In addition, TACFIRE devices must be cabled directly to the SIP/ASIP RT AUD/DATA connector.

**2.2b. SIP/ASIP RT Keypad**

<b>General</b>	The keypad of the SIP/ASIP radio is similar to that of earlier versions except four of the keys have been given new designations: RCU, GPS, SA, and CID. The ASIP keypad adds a MENU and Backlight function. Each is explained below.
<b>RCU/(P)</b>	The RCU key is used to select operating mode options of RT RCU, EXT, or LDE. RT is the normal employment of the RT as a receiver-transmitter. Selecting RCU allows the SIP/ASIP RT to be used as a remote control device. EXT is a capability of the SIP/ASIP that allows the radio to be controlled externally via the system connector. The ASIP radio is automatically in EXT when proper interface and software is detected. Selecting EXT disables the front panel controls of the RT. EXT is used for GRM-122 testing. LDE stands for local data entry and represents a future capability of the SIP/ASIP RT to communicate with SIP/ASIP VAA regarding data loads and requirements. This feature is currently not used.

**GPS/(5)** The GPS key is not used; it represents a possible future capability of the SINCGARS SIP/ASIP radio.

**SA/(6)** The SA key is not used; it represents a possible future capability of the SINCGARS SIP/ASIP radio.

**CID/(8)** The CID key is not used; it represents a possible future capability of the SINCGARS SIP/ASIP radio.

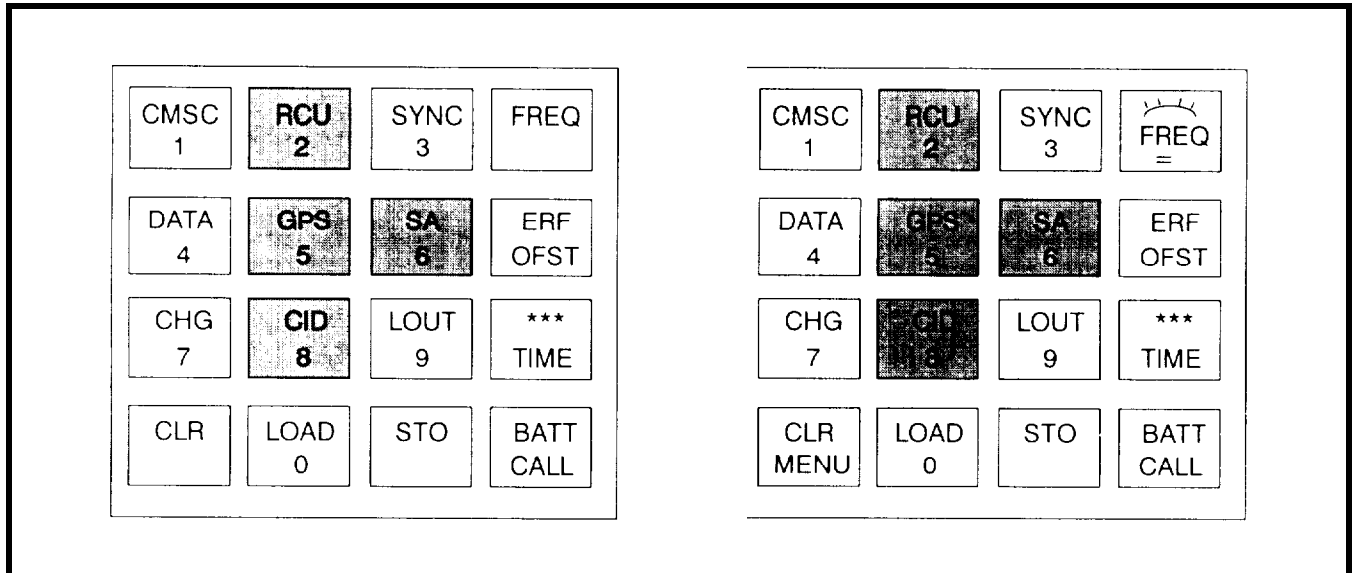

**Figure 2-8. SIP/ASIP Keypad**

**CLR/MENU** MENU appears on SINCGARS ASIP when key is pressed. Multiple presses will scroll MENU.

**FREQ/BACKLIGHT** ASIP radio must be in SQ ON, press key [FREQ], then CHG to change intensity.

**2.2c. SIP/ASIP VAA**

**Memory** The SIP/ASIP VAA contains a small microprocessor which allows data in the form of routing tables to be stored in the SIP/ASIP VAA.

**Internet** When used in conjunction with FBCB2 hardware and software, the SIP/ASIP VAA supports internet communications among SINCGARS FH nets and between SINCGARS and EPLRS nets. Employment of the internet feature requires that the SIP/ASIP RT be set to the Packet data mode.

**2.2d. Connectors, SIP RT**

**P1 (System)**

The P1 systems connector is located on the back of the SIP RT. This connector provides RT power and signaling interfaces.

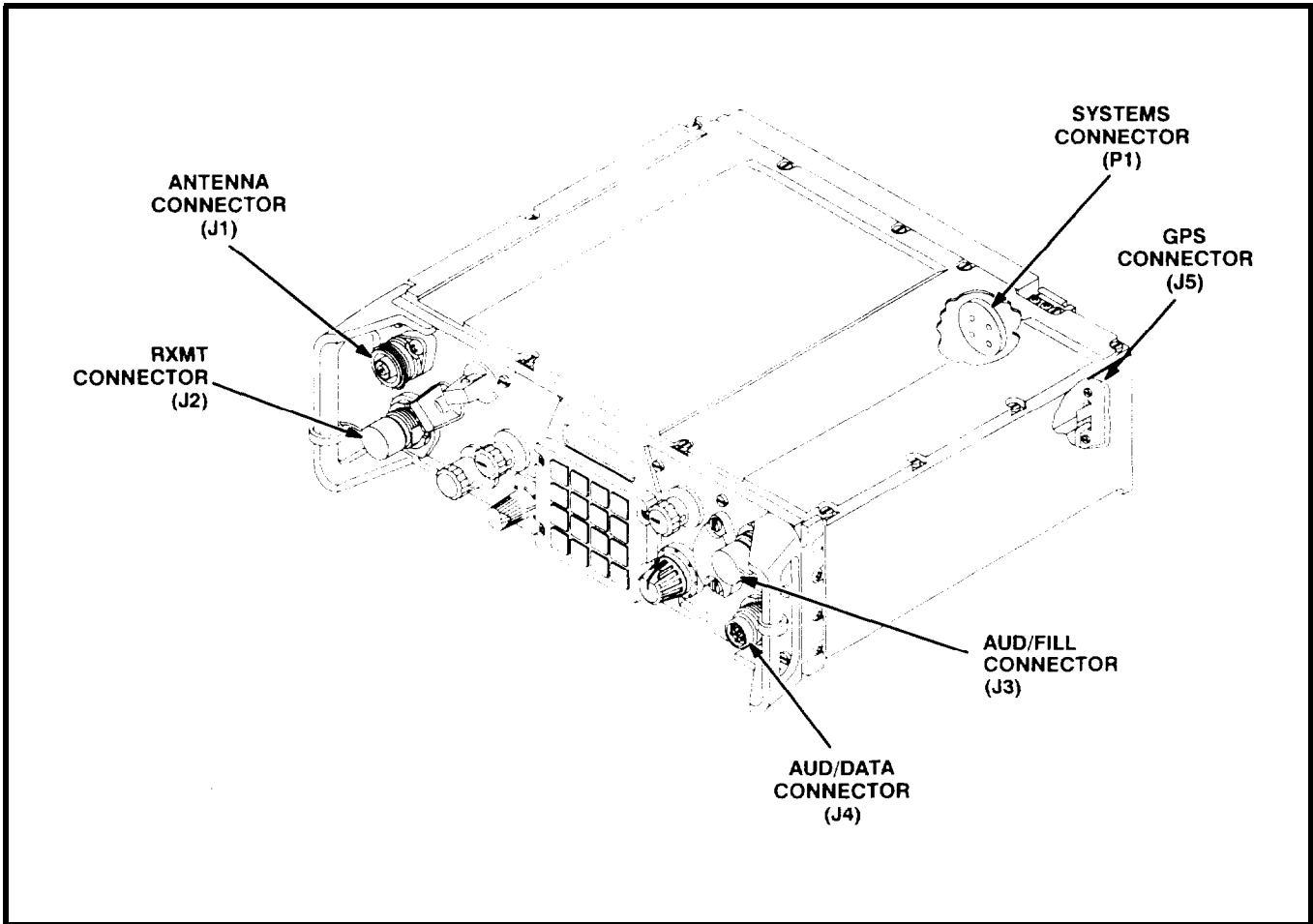

**Figure 2-9. SIP RT Connectors**

**J5 (GPS)**

Located on the back of the SIP RT, the GPS J5 connector provides an interface of the VAA GPS connector.

**J4 (AUD/DATA)**

The J4 (AUDIDATA) connector supports general data communications at SINCGARS Data Rates of 600, 1200, 2400, 4800 and 16,000 BPS and Enhanced Data Rates of 1200N, 2400N, 4800N, and 9600N BPS. The RS-232 interface allows transmission of data via SINCGARS SIP radios using computers and commercial "Xmodem" software. If not using Packet (PKT) data mode, or the internet controller (INC) feature of the SIP radio, all data devices must be connected to the AUD/DATA port, not to the SIP VAA.

**J3 (AUD/FILL)**

Handsets used with the SIP RT may be connected to the AUD/DATA or AUD/FILL connector. (NOTE: Handsets will not function if connected to the front of the SIP VAA.)



**2.2e. Connectors, ASIP RT**

**P1 (System)**

This connector provides RT power and signaling interfaces.

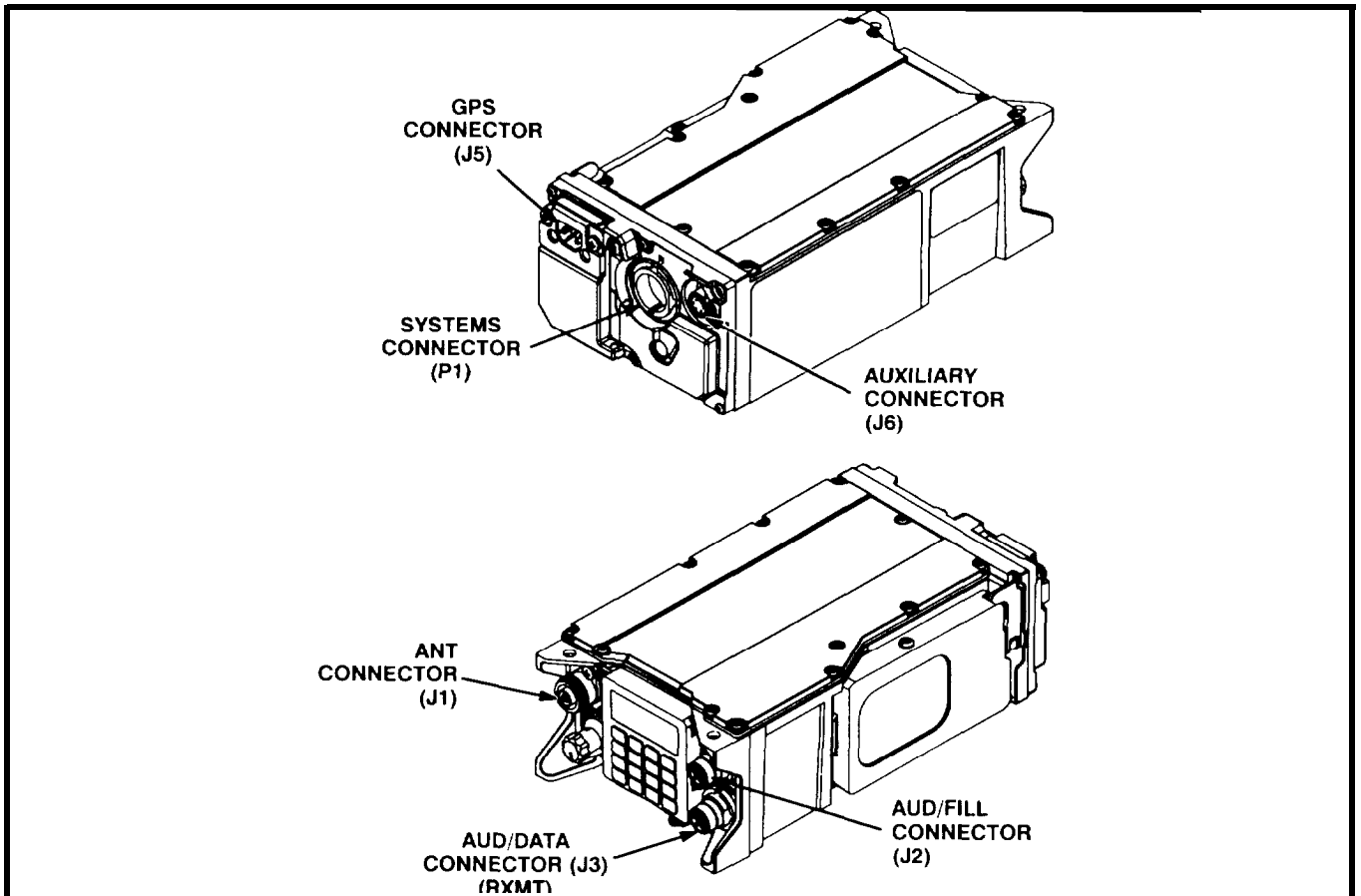

**Figure 2-10. ASIP RT Connectors**

**J6 (Auxiliary)**

Used to connect HRCRD handset and two-wire adapter.

**J5 (GPS)**

Enables a PLGR to be connected to a manpack radio.

**J3 (AUD/DATA)**

The J4 (AUD/DATA) connector supports general data communications at SINCGARS Data Rates of 600, 1200, 2400, 4800 and 16,000 BPS and Enhanced Data Rates of 1200N, 2400N, 4800N, and 9600N BPS. The RS-232 interface allows transmission of data via SINCGARS ASIP radios using computers and commercial "Xmodem" software. If not using Packet (PKT) data mode, or the internet controller (INC) feature of the ASIP radio, all data devices must be connected to the AUD/DATA port, not to the ASIP VAA.

**J2 (AUD/FILL)**

Handsets used with the ASIP RT may be connected to the AUD/DATA or AUD/FILL connector. (NOTE: Handsets will not function if connected to the front of the ASIP VAA.)

**J1 (Antenna)**

RF Input/Output.

**2.2f. RT Messages**

**“CALL”**

This message appears in the display of a remoted radio when an RCU(RT) operator presses the CALL key, and at the RCU(RT) when the remoted radio operator presses the CALL key.

**“EXT”**

If your radio has been set to EXT, as an option of the RCU key menu, an “EXT” message will be displayed. All RT front panel controls except COMSEC are disabled. Unless you want to use the EXT feature, use the RCU key to turn EXT mode off. The ASIP RT is always in an EXT mode as long as it detects proper interface and software, EXT will not be displayed.

**“Fail 5”**

If a “Fail 5” message is displayed during power-up and BIT, it means one of three things:

- (1) You have an ANCD or other fill device connected to the RT. Disconnecting the fill device will correct the FAIL 5 situation.
- (2) You have mistakenly set the COMSEC switch to Z. Moving the COMSEC switch to another position will correct the FAIL 5 situation.
- (3) The RT tamper switch has been activated or there is a hard COMSEC failure, in which case you need to see your unit maintainer.

**“Fail 6”**

This message applies to INC and HFMUX failures.

**“G”**

When GPS time has been successfully loaded into the SIP/ASIP radio, the letter “G” will be displayed. When a radio loaded GPS time is returned to SQ ON from STBY, a blinking “G” indicates that GPS time needs to be reloaded. Disappearance of the “G” indicates that the radio is no longer using GPS time.

**“GOPT”**

Indicates that the SIP/ASIP radio has experienced a COMSEC failure; operator must change to PT in order to continue to communicate.

**“GOTST”**

When this message appears, it indicates a COMSEC problem. The radio will not transmit, receive, or fill until BIT has successfully run. If you cannot get the RT to run BIT successfully, action by unit maintenance is needed.

**“NOGPS”**

This message appears when attempting to load GPS time without a GPS device (PLGR) attached.

**“NOKEY”**

If you power-up your radio in CT when there are no COMSEC keys loaded, a “NOKEY” message will be displayed and a COMSEC alarm will be heard. Setting COMSEC to PT or loading a COMSEC key will clear the alarm.

**“PT RX”**

This message will be displayed whenever you have your radio in CT and receive a PT message.

**“SETDR”**

For transmission operation, this message tells the RXMT operator who selects RS-232 that an EDM data rate (1200N, 2400N, 4800N, or 9600N) must be selected before RS232 transmissions can be started. (NOTE: All SIP/ASIP radios using RS232 mode must be set to the same EDM data rate.)

**“WAIT”**

This message is displayed while BIT is running, changing to the message “GOOD” when BIT is successful.

**2.29. RT Physical Data**

NOTE: Weights are in kilograms; measurements are in centimeters. The numbers in parentheses show equivalent pounds and inches. All weights are approximate; all measurements are maximums.

Table 2-1. Receiver-Transmitter Physical Data

ITEM	LENGTH	WIDTH	HEIGHT	WEIGHT
RT-1523	25.3 (10.0)	27.1 (10.7)	8.7 (3.4)	6.7 (14.7)
RT-1523A	25.3 (10.0)	27.1 (10.7)	8.7 (3.4)	6.9 (15.2)
RT-1523B/C/D	25.3 (10.0)	27.1 (10.7)	8.7 (3.4)	6.2 (13.7)
RT-1523E	25.6 (10.1)	13.5 (5.3)	13.5 (5.3)	3.6 (8.0)

**2.2h. Common Connections**

Table 2-2. Common Connections

ITEM	AUD/DATA	AUD/FILL	VAA J4/J5	BTRY BOX	AUX (ASIP)
ANCD		X			
Computer	X				
Handset	X*	X			
HRCRD	X	X		X	X
PLGR		X			
TF/FSK	X				
2-Wire Adapter					X
W-4**	X		X		

- . Handset H-250 cannot be connected to the AUD/DATA port when the Packet mode is in use.
- . \* Connecting a PLGR to the GPS port (J5/J12) of the RT or VAA requires a special cable.
- \*\*\*A W-4 cable is used to connect the VAA J5 (RT-A) or VAA J4 (RT-B) for Packet data only.

**2.3. MANPACK (MP) RADIOS (AN/PRC-119A/D/F)**

**2.3a. Manpack Radios, General**

**NOMENCLATURE**

The term “manpack” is the common name for the soldier carried AN/PRC-119A/D/F. (The “A/D/F” indicates this is an ICOM radio. Do not confuse this designation with the A found in RT version and other component numbers.)

**DISMOUNT**

Dismount is the term used to indicate that the equivalent of a manpack radio is included within the components of selected vehicular radios. Once assembled, there is no difference between a radio referred to as manpack and one called dismount.

**2.3b. Manpack Radio Components**

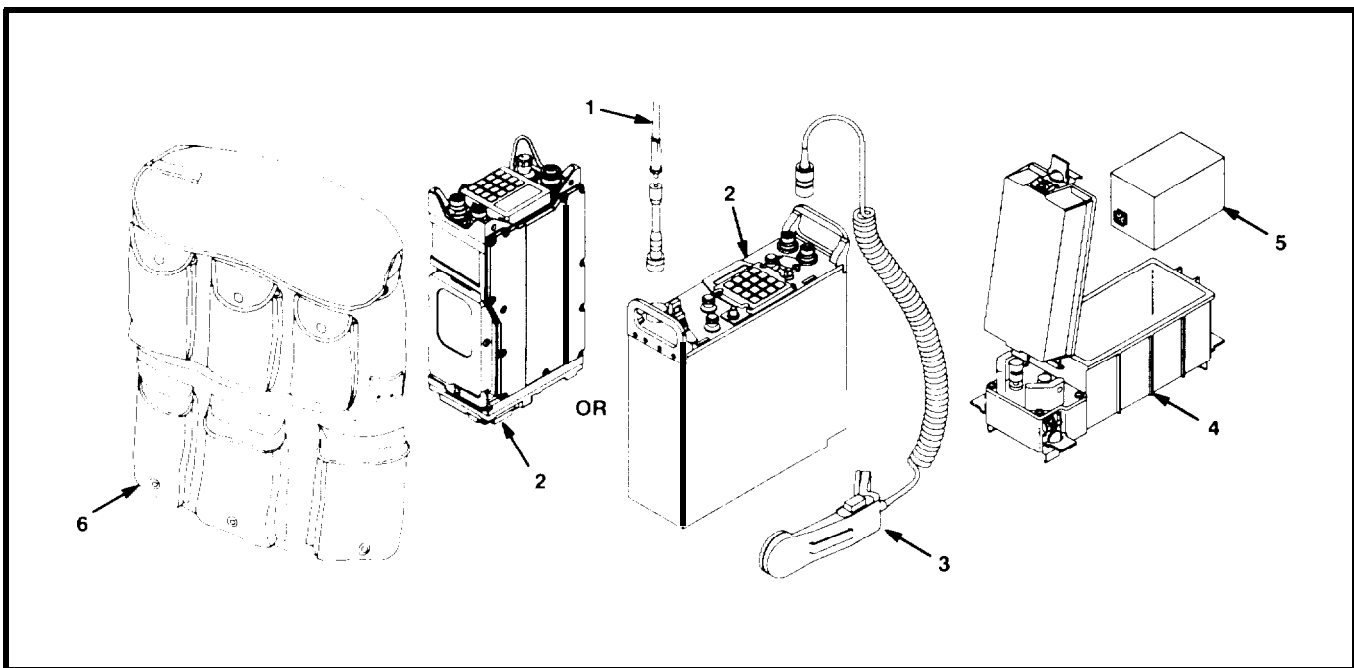

1. Antenna, manpack radio: may be AS-3683/PRC or AS-4266/PRC (long antenna).
2. Receiver-Transmitter (RT): may be RT-1523 Series.
3. Handset: H-250/U or Handheld Remote Control Radio Device (HRCRD) (C-12493/U).
4. Battery Box: may be CY-8523A/B, (CY-8523C is used with the HRCRD). Not required for ASIP RT.
5. Battery, main power: may be Battery, Non-Rechargeable, BA-5590/U; Battery, Rechargeable, BB-590/U; or Battery, Rechargeable, BB-390/U.
6. Carrying Case.

**Figure 2-11. Manpack Radio Components**

**2.3c. Manpack Radio Physical Data**

NOTE: Weights are in kilograms; measurements are in centimeters. The numbers in parentheses show equivalent pounds and inches. All weights are approximate; all measurements are maximums.

**Table 2-3. Manpack Radio Physical Data**

ITEM	LENGTH	WIDTH	HEIGHT	WEIGHT
Battery Box, CY-8523A, -8523B, or -8523C	23.4 (9.2)	8.5 (3.3)	12.8 (5.0)	1.4 (2.4)
Battery, BA-5590	12.5 (4.9)	5.8 (2.3)	10.9 (4.3)	1.0 (2.25)
Battery, BB-390	12.5 (4.9)	5.8 (2.3)	10.9 (4.3)	n/a
Battery, BB-590	12.5 (4.9)	5.8 (2.3)	10.9 (4.3)	1.8 (4.05)
Antenna, AS-3683	104.9 (41.3)	n/a	n/a	0.3 (0.7)
Antenna (long), AS-4266*	264.2 (104)	n/a	n/a	0.7 (1.5)
Handset, H -250	n/a	n/a	n/a	0.25 (0.55)
Carrying Case	50.2 (19.8)	36.2 (14.3)	18.0 (7.1)	3.2 (7.0)
Manpack Radio (with RT-1523)**	n/a	n/a	n/a	12.6 (27.7)
Manpack Radio (with RT-1523A)**	n/a	n/a	n/a	12.8 (28.2)
Manpack Radio (with RT-1523B)**	n/a	n/a	n/a	12.1 (26.6)
Manpack Radio (with RT-1523C)**	n/a	n/a	n/a	12.4 (26.9)
Manpack Radio (with RT-1523D)**	n/a	n/a	n/a	12.4 (26.9)
Manpack Radio (with RT-1523E)**	n/a	n/a	n/a	TBD

\* Length of long antenna when folded is 45.7 CM (18 IN).

\*\* When using BA-5590 as main power battery and short antenna (AS-3683/A).

**2.3d. Manpack Radio\* Performance Data**

**Table 2-4. Manpack Radio Performance Data**

TYPE COMM	RF PWR	RANGE**
<b>VOICE</b>	<b>LOW (LO)</b>	<b>200 M to 400 M</b>
VOICE	MEDIUM (M)	400 M to 5 KM
VOICE	HIGH (HI)	5 KM to 10 KM
DATA (600-4800 BPS)	HIGH (HI)	3 KM to 5 KM
DATA (1600 BPS)	HIGH (HI)	1 KM to 3 KM
* ** EDM DATA (1200N)	HIGH (HI)	5 KM to 10 KM
<b>EDM DATA (2400N)</b>	<b>HIGH (HI)</b>	<b>5 KM to 8 KM</b>
EDM DATA (4800N)	HIGH (HI)	3 KM to 5 KM
EDM DATA (9600N)	HIGH (HI)	1 KM to 3 KM

\* Above data apply equally to dismount radios and RCUs.

\*\* Ranges shown are for planning purposes only. They are based upon line of sight and are average for normal conditions. Ranges depend upon location, sighting, weather, and surrounding noise level, among other factors. Use of the OE-254 antenna will increase ranges for both voice and data transmissions. Enemy jamming and mutual interference conditions will degrade ranges. In data transmissions, use of lower baud rate increases the range.

\*\*\* EDM data rates are available on C, D, and E Model radios.

**2.4. BATTERY REQUIREMENTS**

**2.4a. Power Source**

**DESCRIPTION**

SIP manpack radios, including those in dismount kits of AN/VRC-88A/D and AN/VRC-90A/D configurations, require batteries for their main power source and hold-up (memory retention) function. This paragraph offers users of SIP radios with general guidelines regarding the number of hours of a particular type usage each battery is expected to provide. These times are based on computations as well as experience. Actual battery life will vary depending upon how long the battery has been in storage and the temperature at the time the battery is being used. Even so, these times offer you a basis for planning your battery requirements.

**2.4b. Main Power**

**DESCRIPTION**

Batteries used for main power in the SIP radio are:

- Battery, Rechargeable, BB-390A/U.
- Battery, Rechargeable, BB-590/U.
- Battery, Non-Rechargeable, BB-5590/U (Lithium)

**2.4c. HUB**

**DESCRIPTION**

The Hold-Up Battery used in SIP radios is Battery, Non-Rechargeable, BA-5372/U (Lithium).

**2.4d. Manpack Radio**

**ESTIMATED BATTERY LIFE USING BA-5590, RFPWR AT HI SETTING\***

**Table 2-5. Manpack Radio Main Power**

VOICE/DATA (FH & CT)	RT-1523	RT-1523A	RT-1523B	RT-1523C	RT-1523D	RT-1523E
Normal (OPR)*	18 Hours	30 Hours	26 Hours	28 Hours	TBD	33 Hours
Heavy (NCS)**	11 Hours	18 Hours	15 Hours	18 Hours	TBD	TBD
Standby (STBY) ****	3 Months	3 Months	3 Months	3 Months	3 Months	3 Months

\* Use of HRCRD reduces times shown by approximately one-half hour.

\*\* Represents 9 minutes of receiving and monitoring to every 1 minute of transmitting.

\*\*\* Represents 2 minutes of receiving and monitoring to every 1 minute of transmitting.

\*\*\*\* In STBY, RT draws power from main battery not the HUB.

**2.4e. RCU(RT)**

**ESTIMATED BATTERY LIFE, BA-5590, FOR RT USED AS RCU**

**Table 2-6. SIP/ASIP RT used As RCU - Main Power**

<b>VOICE/DATA (FH &amp; CT)</b>	<b>RT-1523C</b>	<b>RT-1523D</b>	<b>RT-1523E</b>
Normal (OPR)	TBD	TBD	TBD
Heavy (NCS)	TBD	TBD	TBD
Standby (STBY)	3 Months	3 Months	3 Months

**2.4f. Hold-Up Battery**

**ESTIMATED HOLD-UP BATTERY LIFE, BA-5372, SIP RADIO**

**Table 2-7. SIP/ASIP Radio Hold-Up Battery**

<b>USE</b>	<b>RT-1523</b>	<b>RT-1523A</b>	<b>RT-1523B</b>	<b>RT-1523C</b>	<b>RT-1523D</b>	<b>RT-1523E</b>
Back-Up	6 Months	6 Months	6 Months	6 Months	6 Months	6 Months

**CAUTION**

**SINGGARS HUB and ANCD batteries look similar and can be physically interchanged. The HUB battery is 6.5 Volts while ANCD batteries are 3 Volts each. If HUB batteries (3 of them) are mistakenly placed in the ANCD, it will be destroyed. Placing one ANCD battery in the RT HUB position will cause the RT to lose its fill of data. Therefore, be sure you know which battery goes where. Always read the label before installing either HUB or ANCD batteries!**



## 12.5. VEHICULAR (VEH) RADIOS (AN/VRC-87A/D/F thru 92A/D/F)

### 2.5a. Vehicular Radios, General

#### CONFIGURATIONS

There are six configurations of vehicular radios. They are:

- Short Range (SR) Radio (AN/VRC-87A/D/F\*)
- Short Range Radio with Dismount (AN/VRC-88A/D/F)
- Long Range (LR) Radio (AN/VRC-90A/D/F)
- Short Range/Long Range Radio (AN/VRC-89A/D/F)
- Short Range/Long Range Radio with Dismount (AN/VRC-91A/D/F)
- Long Range/Long Range Radio (AN/VRC-92A/D/F)

\* The "A/D/F" in SINGARS radio nomenclature means that these are ICOM radios. Do not confuse this designation with the A in RT version or other component numbers. The "C" in radio nomenclature indicates Single Radio Mount (SRM) radios.

#### COMPONENTS

The components which are used in all vehicular radio configurations are shown below in graphic form for ease of reference. Specific components which make up each configuration are listed under each radio designation

- |     |   |
|-----|---|
| 1.  | Receiver-Transmitter (RT) (RT-1523/A/B/C/D).                            |
| 2.  | Mounting Base (MB) (MT-6352/A), part of installation kit.               |
| 3.  | Vehicular Amplifier Adapter (VAA) (AM-7239/A/B/C/D/E).                  |
| 4.  | Vehicular Antenna (AS-3900), part of installation kit.                  |
| 5.  | SINGARS Low Profile Antenna (SLPA) (AS-3916), part of installation kit. |
| 6.  | Handset (HS) (H-250), part of installation kit.                         |
| 7.  | Loudspeaker (LS) (LS-671), part of installation kit.                    |
| 8.  | Power Amplifier (PA) (AM-7238/A/B).                                     |
| 9.  | Power Amplifier Mount (PA Mt) (MT-6353).                                |
| 10. | Cable (W2).   |
| 11. | Cable (W4).   |
| 12. | Control-Monitor (C-M)(C-11291A), part of installation kit.              |
| 13. | Receiver-Transmitter (RT) (RT-1523E).                                   |

Figure 2-12. Vehicular Radio Components

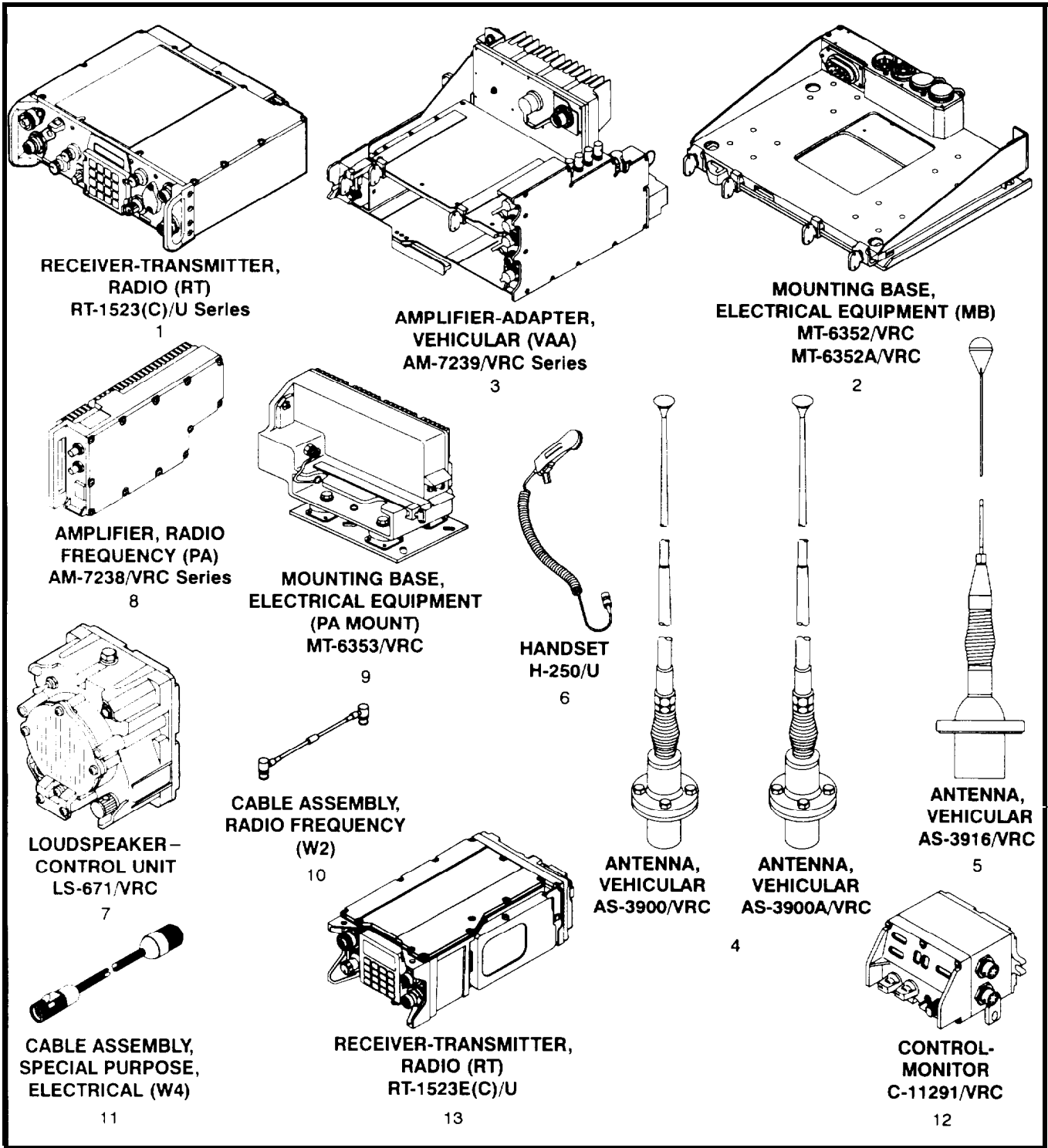
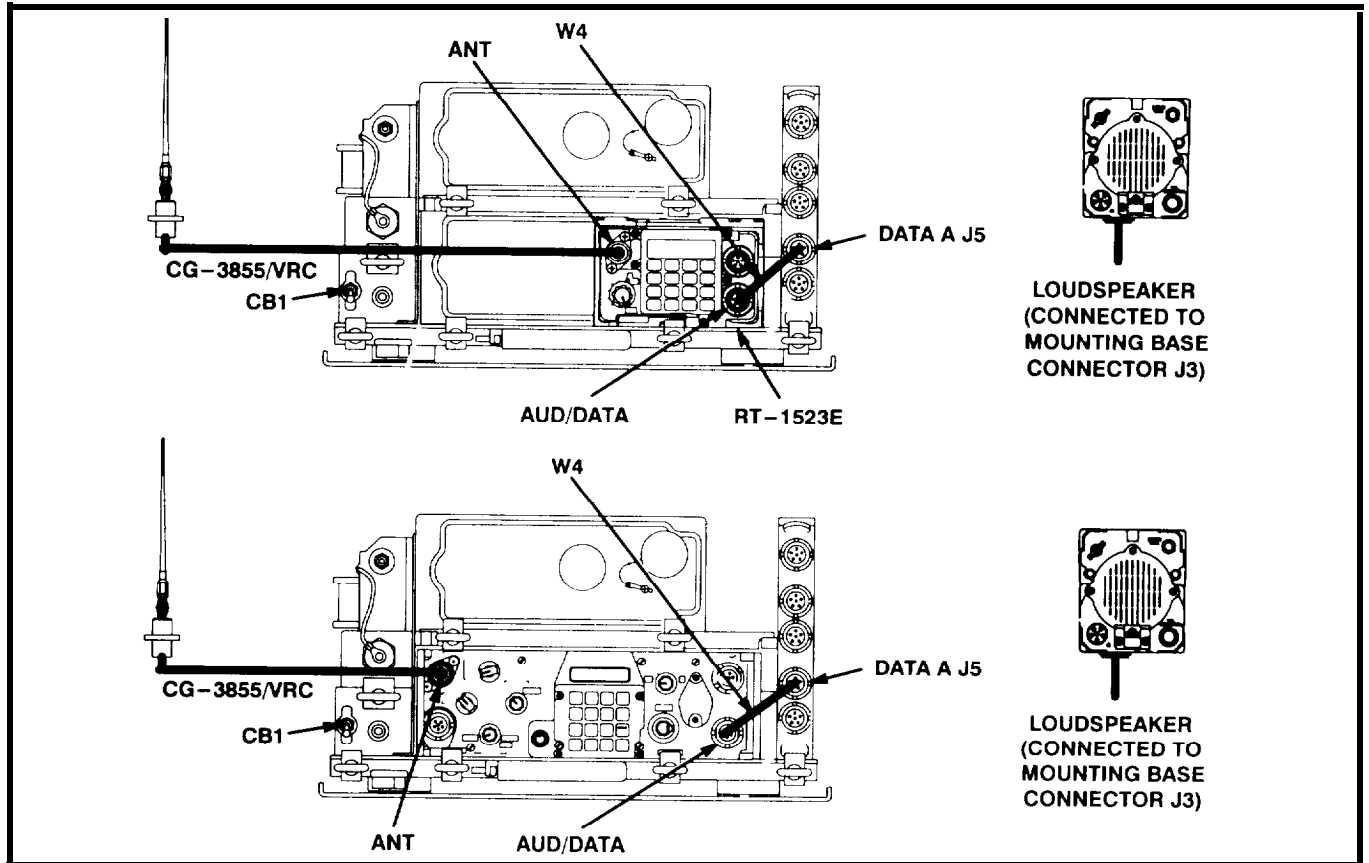

Figure 2-13. SINCGARS Radio Components

**2.5b. Short Range (SR) Radio Components (AN/VRC-87A/D/F)**



1. Receiver-Transmitter (RT) (RT-1523/A/B/C/D/E).
2. Mounting Base (MB) (MT-6352/A), part of installation kit.
3. Vehicular Amplifier Adapter (VAA) (AM-7239/A/B/C/D/E).
4. Vehicular Antenna (AS-3900/3916), part of installation kit.
5. Handset (HS) (H-250), part of installation kit.
6. Loudspeaker (LS) (LS-671), part of installation kit.
7. Cable (W4), connects RT to VAA.
8. Antenna Cable (CG-3856), part of installation kit.
9. Loudspeaker Cable (CX-13292), part of installation kit.
10. Power Cable, part of installation kit.

**Figure 2-14. Short Range (SR) Radio Components**

**2.5c. Short Range Radio with Dismount (SR-D) Components (AN/VRC-88A/D/F)**

Same as Short Range Radio, plus Dismount (Manpack) Radio.

**2.5d. Long Range (LR) Radio Components (AN/VRC-90A/D/F)**

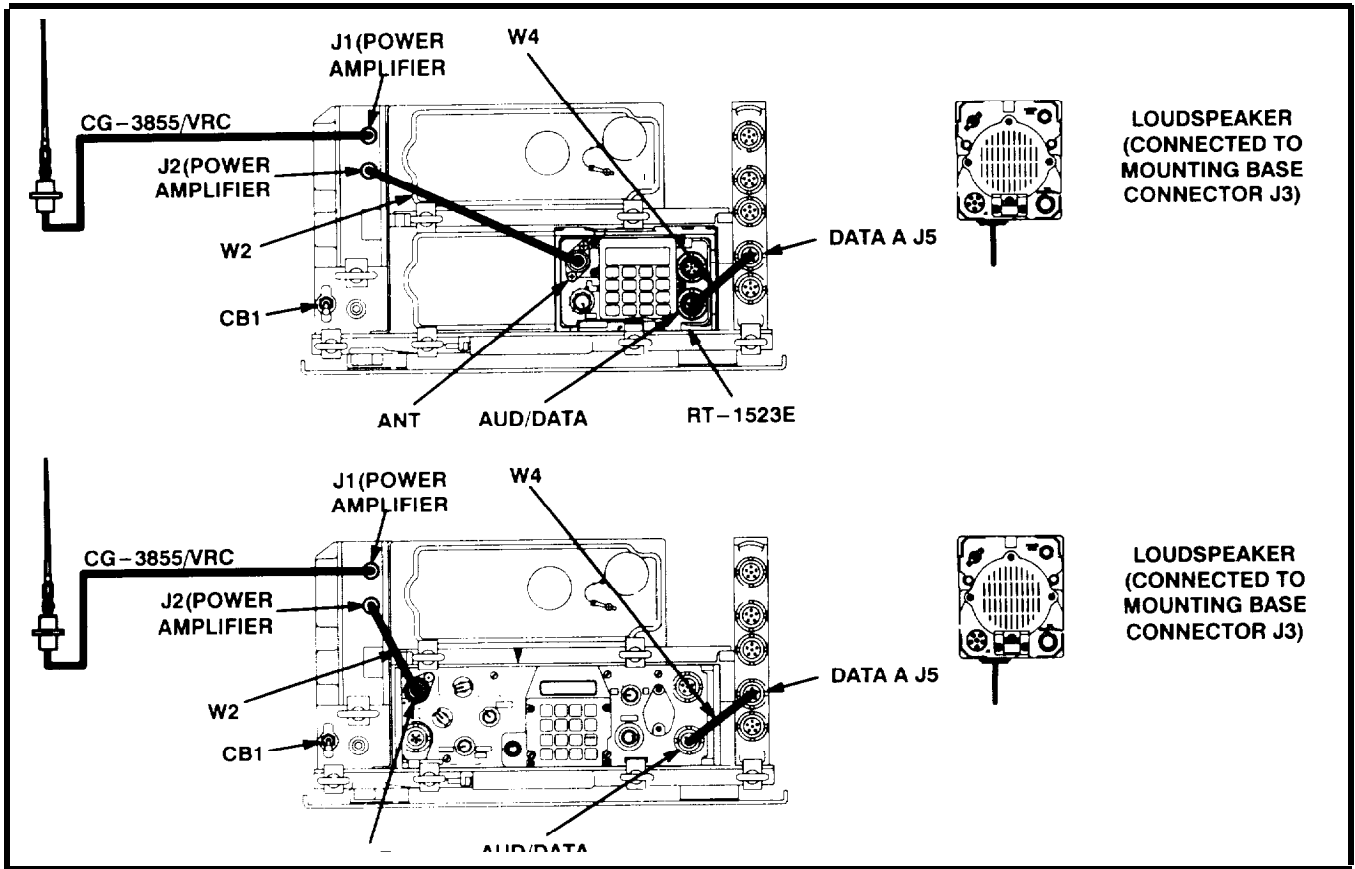

1. Receiver-Transmitter (RT) (RT-1523/A/B/C/D/E).
2. Mounting Base (MB) (MT-6352/A), part of installation kit.
3. Vehicular Amplifier Adapter (VAA) (AM-7239/A/B/C/D/E).
4. Vehicular Antenna (AS-3900/3916), part of installation kit.
5. Handset (HS) (H-250), part of installation kit.
6. Loudspeaker (LS) (LS-671), part of installation kit.
7. Power Amplifier (PA) (AM-7238/A/B).
8. Cable (W2), connects RT ANT to PA.
9. Cable (W4), connects RT to VAA.
10. Antenna Cable (CG-3856), part of installation kit.
11. Loudspeaker Cable (CX-13292), part of installation kit.
12. Power Cable, part of installation kit.

**Figure 2-15. Long Range (LR) Radio Components**

**2.5e. Short Range/Long Range Radio Components (AN/VRC-89A/D/F)**

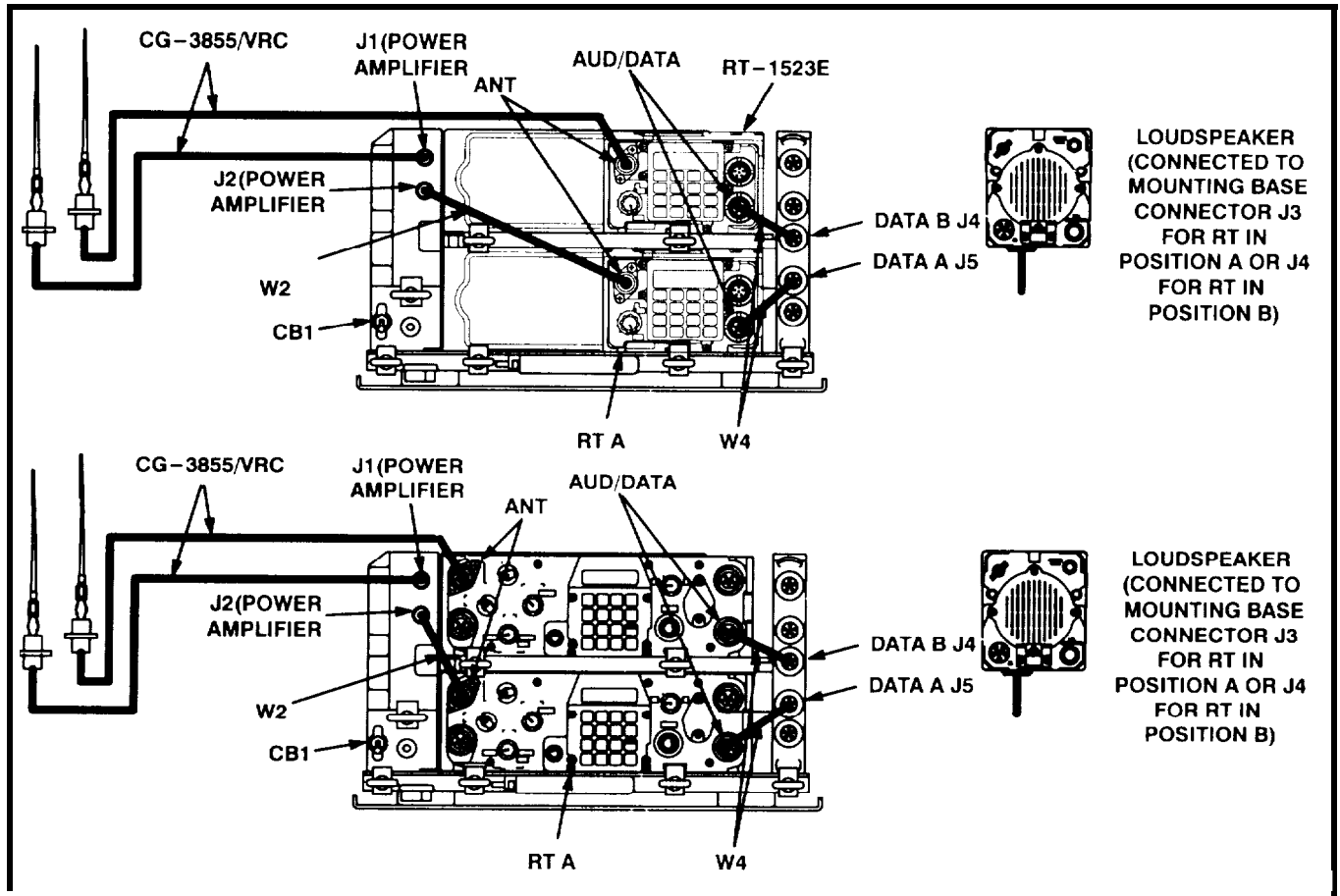

1. 2 Receiver-Transmitters (RT) (RT-1523/A/B/C/D/E).
2. Mounting Base (MB) (MT-6352/A), part of installation kit.
3. Vehicular Amplifier Adapter (VAA) (AM-7239/A/B/C/D/E).
4. Vehicular Antenna (AS-3900/3916), part of installation kit.
5. 2 Handsets (HS) (H-250), part of installation kit.
6. 2 Loudspeakers (LS) (LS-671), part of installation kit.
7. Power Amplifier (PA) (AM-7238/A/B).
8. Cable (W2), connects RT ANT to PA.
9. 2 Cables (W4), connect RTs to VAA.
10. 2 Antenna Cables (CG-3856), part of installation kit.
11. 2 Loudspeaker Cables (CX- 13292), part of installation kit.
12. Power Cable, part of installation kit.

**Figure 2-16. Short Range/Long Range (SR/LR) Radio Components**

**2.5f. Short Range/Long Range Radio with Dismount Components (AN/VRC-91A/D/F)**

Same as Short Range/Long Range Radio, plus Dismount (Manpack) Radio.

**2.5g. Long Range/Long Range Radio Components (AN/VRC-92A/D/F)**

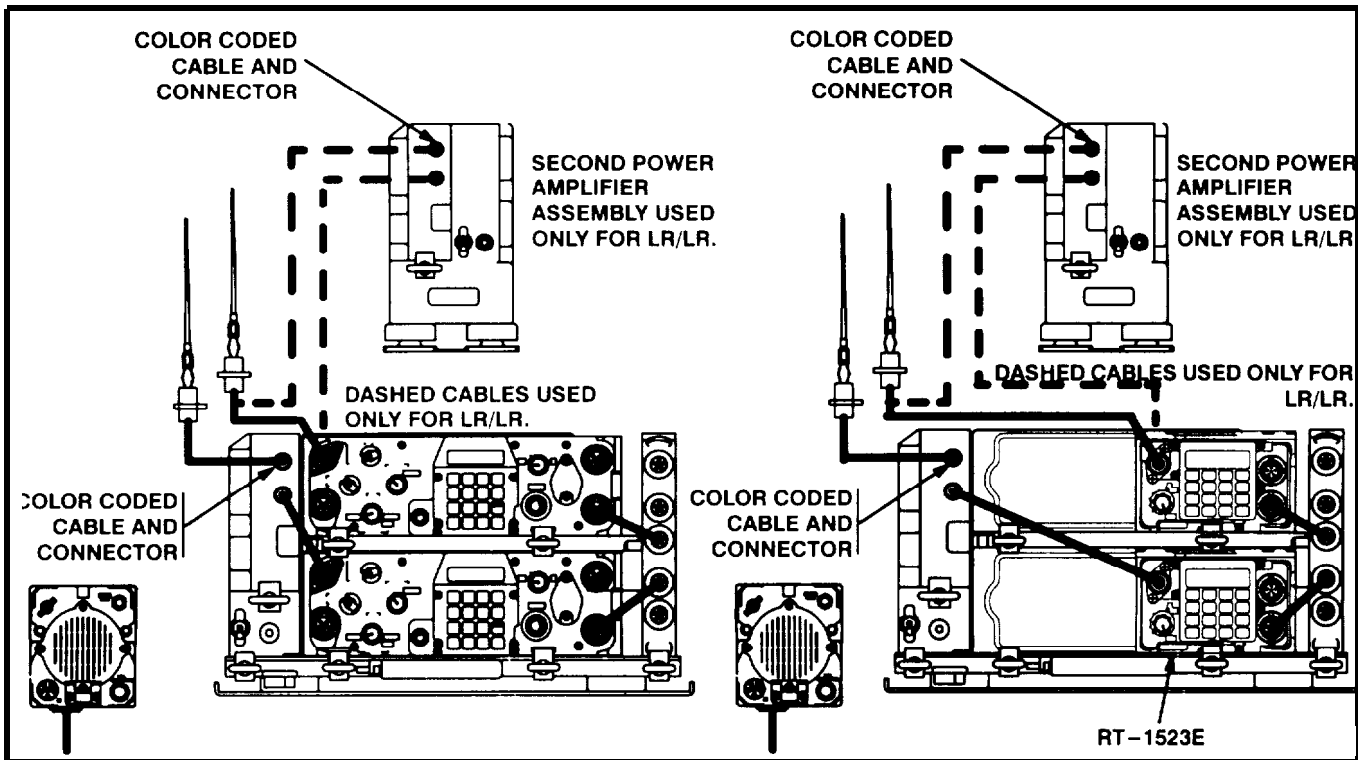

1. 2 Receiver-Transmitters (RT) (RT-1523/A/B/C/D/E).
2. Mounting Base (MB) (MT-6352/A), part of installation kit.
3. Vehicular Amplifier Adapter (VAA) (AM-7239/A/B/C/D/E).
4. Vehicular Antenna (AS-3900/3916), part of installation kit.
5. 2 Handsets (HS) (H-250), part of installation kit.
6. 2 Loudspeakers (LS) (LS-671), part of installation kit.
7. 2 Power Amplifiers (PA) (AM-7238/A/B).
8. Power Amplifier Mount (PA Mt) (MT-6353).
9. Cable (W2), connects RT ANT to PA.
10. 2 Cables (W4), connect RTs to VAA.
11. 3 Cable (CG-3856), 1 connects PA to antenna (5') (2 are in installation kit).
12. Cable (CX-13291), connects RT-B PA Mt to VAA.
13. Cable (CX-13298), connects RT-A to RT-B for RXMT.
14. Cable (CX-13303), connects RT-B PA Mt to MB.
15. 2 Loudspeaker Cables (CX-13292), part of installation kit.

**Figure 2-17. Long Range/Long Range (LR/LR) Radio Components**

**2.5h. VAA Connectors (A/B models)**

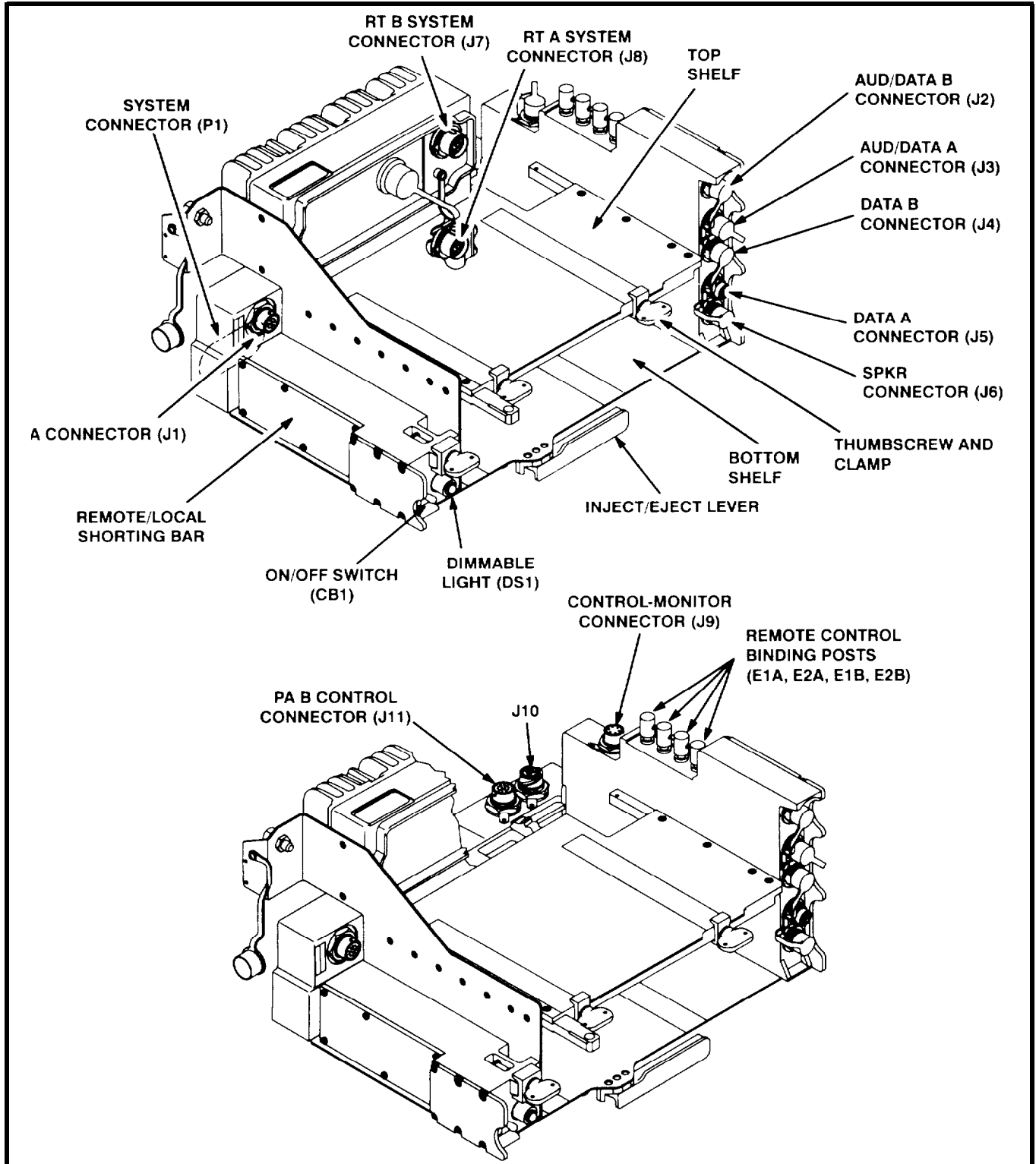

Figure 2-18. VAA Connectors

<b>J1</b>	RF PA Control (RT-A); provides control lines and power supply for the RF Power Amplifier (PA).
<b>J2</b>	AUD/DATA-B provides for connection of handset or data device for RT-B.
<b>J3</b>	AUD/DATA-A; provides for connection of handset or data device for RT-A.
<b>J4</b>	DATA-B; 6-pin connector used to couple VAA J4 to RT-B AUD/DATA port using a W-4 cable. (W-4 cable must be connected for use of J2 connector)
<b>J5</b>	DATA-A; 6-pin connector used to couple VAA J5 to RT-A AUD/DATA port using a W-4 cable. (W-4 cable must be connected for use of J3 connector)
<b>J6</b>	SPKR; 6-pin connector used to connect LS-454 loudspeaker.
<b>J7</b>	RT-B System Connector; 27-pin system connector for RT-B.
<b>J8</b>	RT-A System Connector; 27-pin system connector for RT-A.
<b>J9</b>	Control-Monitor; 6-pin connector for use of a control-monitor (C-11291).
<b>J10</b>	SNAP: not used.
<b>J11</b>	RF PA Control (RT-B); 14-pin connector for control of external RT-B power amplifier.
<b>E1/2A/B</b>	Two-wire binding posts used for remote control of RT-A/RT-B via C-11561 (RCU) or SIP RTs used as RCUs.
<b>P1</b>	Power connector; couples vehicle 27.5 VDC power to the intercom.
<b>CB1</b>	ON/OFF Switch.
<b>DS1</b>	Power indicator lamp.



2.5i. VAA Connectors (C/D models)

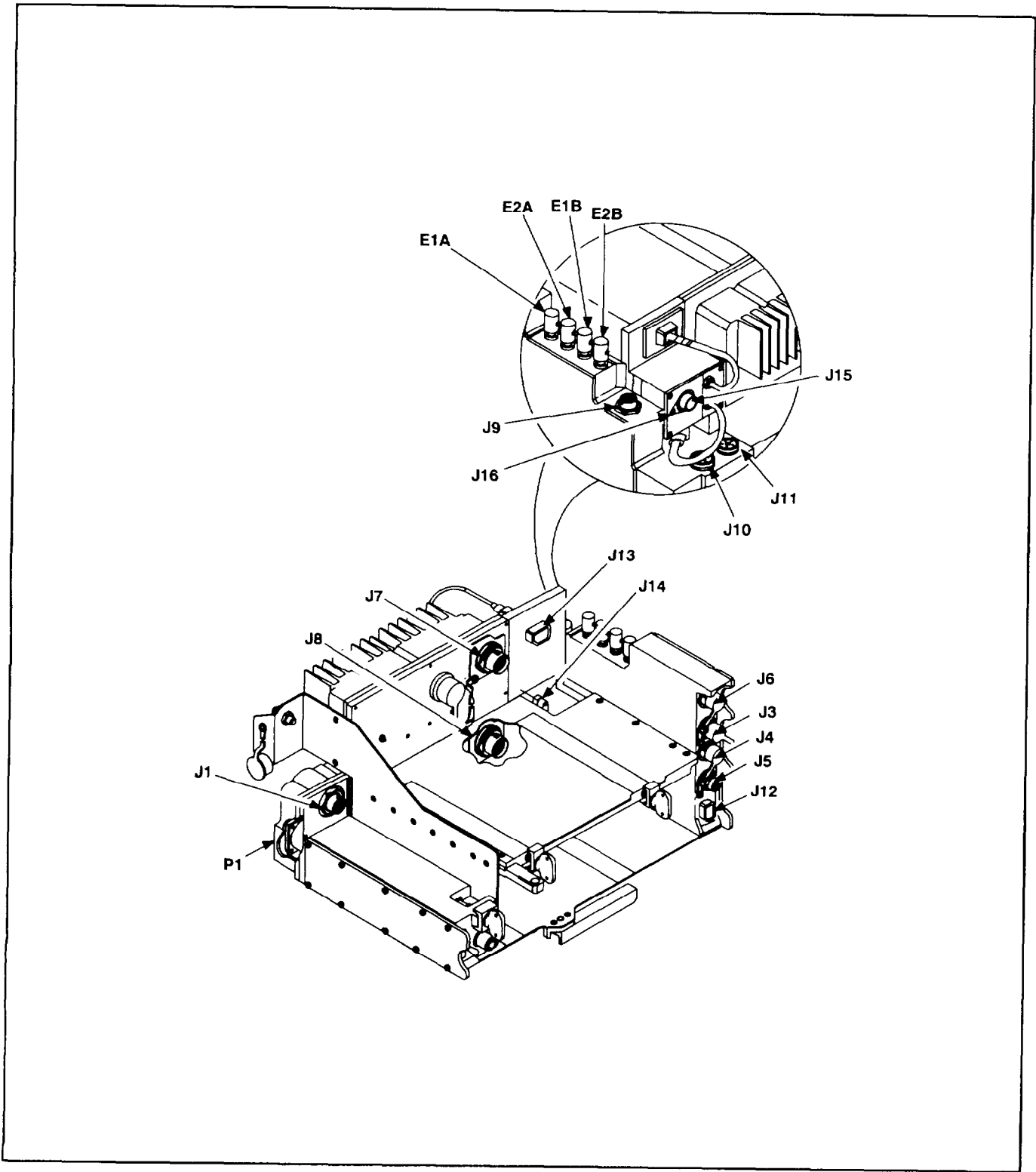

Figure 2-19. SIP VAA Connectors

J1	RF PA Control (FIT-A); provides control lines and power supply for the RF Power Amplifier (PA).
J3	RS-422/RS-423; 19-pin connector for full duplex connections.
J4	DATA-B; 6-pin connector used to couple VAA J4 to RT- BAUD/DATA port using a W-4 cable. (The W-4 cable is used only for Packet data mode operations)
J5	DATA-A; 6-pin connector used to couple VAA J5 to RT-A AUD/DATA port using a W-4 cable. (The W-4 cable is used only for Packet data mode operations)
J6	RS-232/RS-423; 19-pin connector that couples data transfer equipment to the VAA; used for FBCB2 connection.
J7	RT-B System Connector; 27-pin system connector for RT-B.
J8	RT-A System Connector; 27-pin system connector for RT-A.
J9	Control-Monitor; 6-pin connector for use of a control-monitor (C-11291).
J10	Frequency Information Connector; 12-pin connector for frequency information interface from RT-A and RT-B. (Dual SNAP connection for FHMUX)
J11	RF PA Control (RT-B); 14-pin connector for control of external RT-B power amplifier.
J12	GPS In; 6-pin and coax rectangular connector interface for GPS receivers.
J13	GPS-B; interface between GPS buffer and RT-B.
J14	GPS-A; interface between GPS buffer and RT-A.
J16	GPS RF In; interface for GPS antenna.
E1/2A/B	Two-wire binding posts used for remote control of RT-A/RT-B via C-11561 (RCU) or SIP RTs used as RCUs.
P1	Power connector; couples vehicle 27.5 VDC power to the intercom.

**2.5j. Cabling**

<b>HANDSETS</b>	Connected only to the AUD/DATA or AUD/FILL port of the SIP RT; they will not operate if connected to the SIP/ASIP VAA.
<b>RT-A (LOWER SHELF)</b>	Use of a W4 cable from the RT AUD/DATA port to the VAA J5 connector is required only for Packet data mode. The RT-A antenna is connected with a W2 cable from the RT antenna port to the PA connector.
<b>RT-B (TOP SHELF)</b>	Use of a W4 cable from the RT AUD/DATA port to the VAA J4 connector is required only for Packet data mode. The RT-B antenna is connected from the antenna port directly to the antenna for short range radios and from the RT antenna port to the auxiliary PA J2 connector, using cable CG-3855/-3856, for RT-B long range radios.
<b>COMPUTER</b>	Connected to the AUD/DATA port of the SIP/ASIP RT. (Do not attempt to connect your computer to the VAA; it will not work without FDCB2 software installed in the computer and tactical internet software installed in the VAA.)
<b>FSK DEVICES</b>	TacFire and other FSK data devices are connected directly to the AUD/DATA port of the RT, not to the VAA.
<b>HRCRD</b>	Connected to AUD/DATA or AUD/FILL on RT and to 6-pin connector on battery box CY-8523C.

**2.5k. Vehicular Radio Physical Data**

*NOTE: Weights are in kilograms; measurements are in centimeters. The numbers in parentheses show equivalent pounds and inches. A// weights are approximate; all measurements are maximums.*

**Table 2-8. Vehicular Radio Physical Data**

<b>ITEM</b>	<b>LENGTH</b>	<b>WIDTH</b>	<b>HEIGHT</b>	<b>WEIGHT</b>
<b>Mounting Base (MB), MT-6352 Series</b>	<b>40.9 (16.1)</b>	<b>40.4 (15.9)</b>	<b>11.1-11.7 (4.3-4.6)</b>	<b>9.2 (20.3)</b>
<b>Vehicular Amplifier Adapter (VAA), AM -7239 Series</b>	<b>38.6 (15.2)</b>	<b>36.7 (14.4)</b>	<b>19.3 (7.6)</b>	<b>11.0 (24.3)</b>
<b>Vehicular Antenna, AS - 3900</b>	<b>286.6 (112.8)</b>	<b>n/a</b>	<b>n/a</b>	<b>5.3 (11.6)</b>
<b>SINCGARS Low Profile Antenna (SLPA), AS-3916</b>	<b>209.9 (82.6)</b>	<b>n/a</b>	<b>n/a</b>	<b>2.4 (5.3)</b>
<b>Handset (HS), H-250</b>	<b>n/a</b>	<b>n/a</b>	<b>n/a</b>	<b>0.25 (0.55)</b>
<b>Loudspeaker (LS), LS 671</b>	<b>10.6 (4.2)</b>	<b>12.6 (4.9)</b>	<b>16.0 (6.3)</b>	<b>1.1 (2.4)</b>
<b>Power Amplifier (PA), AM 7238 Series</b>	<b>30.7 (12.1)</b>	<b>6.9 (2.7)</b>	<b>13.5 (5.3)</b>	<b>3.1 (6.8)</b>
<b>Power Amplifier Mount (PA Mt), MT-6353</b>	<b>34.6 (13.6)</b>	<b>14.7 (5.8)</b>	<b>12.9 (5.1)</b>	<b>6.0 (13.3)</b>
<b>Receiver-Transmitter, RT-1523</b>	<b>25.3 (10.0)</b>	<b>27.1 (10.7)</b>	<b>(8.7) (3.4)</b>	<b>6.7 (14.7)</b>
<b>Receiver-Transmitter, RT-1523A</b>	<b>25.3 (10.0)</b>	<b>27.1 (10.7)</b>	<b>8.7 (3.4)</b>	<b>6.9 (15.2)</b>
<b>Receiver-Transmitter, RT-1523B/C/D</b>	<b>25.3 (10.0)</b>	<b>27.1 (10.7)</b>	<b>8.7 (3.4)</b>	<b>(13.7)</b>
<b>Receiver-Transmitter, RT- 1523E</b>	<b>25.6 (10.1)</b>	<b>13.5 (5.3)</b>	<b>13.5 (5.3)</b>	<b>3.6 (8.0)</b>
<b>Control-Monitor (C-11291)</b>	<b>11.8 (4.6)</b>	<b>15.1 (5.9)</b>	<b>10.1 (4.0)</b>	<b>1.4 (3.0)</b>

**2.51. Vehicular Radio Performance Data**

Table 2-9. Vehicular Radio Performance Data

TYPE COMM	RF PWR	RANGE*
VOICE (SR or LR RADIO)	LOW (LO)	200 M to 400 M
VOICE (SR or LR RADIO)	MEDIUM (M)	400 M to 5 KM
VOICE (SR or LR RADIO)	HIGH (HI)	5KM to 10KM
VOICE (LR RADIO)	POWER AMPLIFIER (PA)	10KM to 40KM
DATA (SR RADIO) 600-4800 BPS 16000 BPS	HIGH (HI)	3KM to 5KM 1 KM to 3 km
DATA (LR RADIO) 600-2400 BPS 4800 BPS 16000 BPS	POWER AMPLIFIER (PA)	5KM to 25KM 5KM to 22KM 3KM to 10KM
** EDM DATA (SR RADIO) 1200N -2400N BPS 4800N BPS/PCKT 9600N BPS	HIGH (HI)	5KM to 10KM 5KM to 10KM 5KM to 10KM
EDM DATA (LR RADIO) 1200N-2400N BPS 4800N BPS/PCKT 9600N BPS	POWER AMPLIFIER (PA)	20 KM to 35 KM 15KM to 25KM 10KM to 25KM

\* Ranges shown are for planning purposes only. They are based upon line of sight and are average for normal conditions. Ranges depend upon location, sighting, weather, and surrounding noise level, among other factors. Use of the OE-254 antenna will increase ranges for both voice and data transmissions. Enemy jamming and mutual interference conditions will degrade ranges. In data transmissions, use of lower baud rate increases the range.

\*\* EDM Data rates are available on "C" and "D" model radios.

**2.6. SINGLE RADIO MOUNT (SRM) RADIO (AN/VRC-87C)**

**2.6a. Components of Short Range (SR) Radio in Single Radio Mount (AN/VRC-87C) 1**

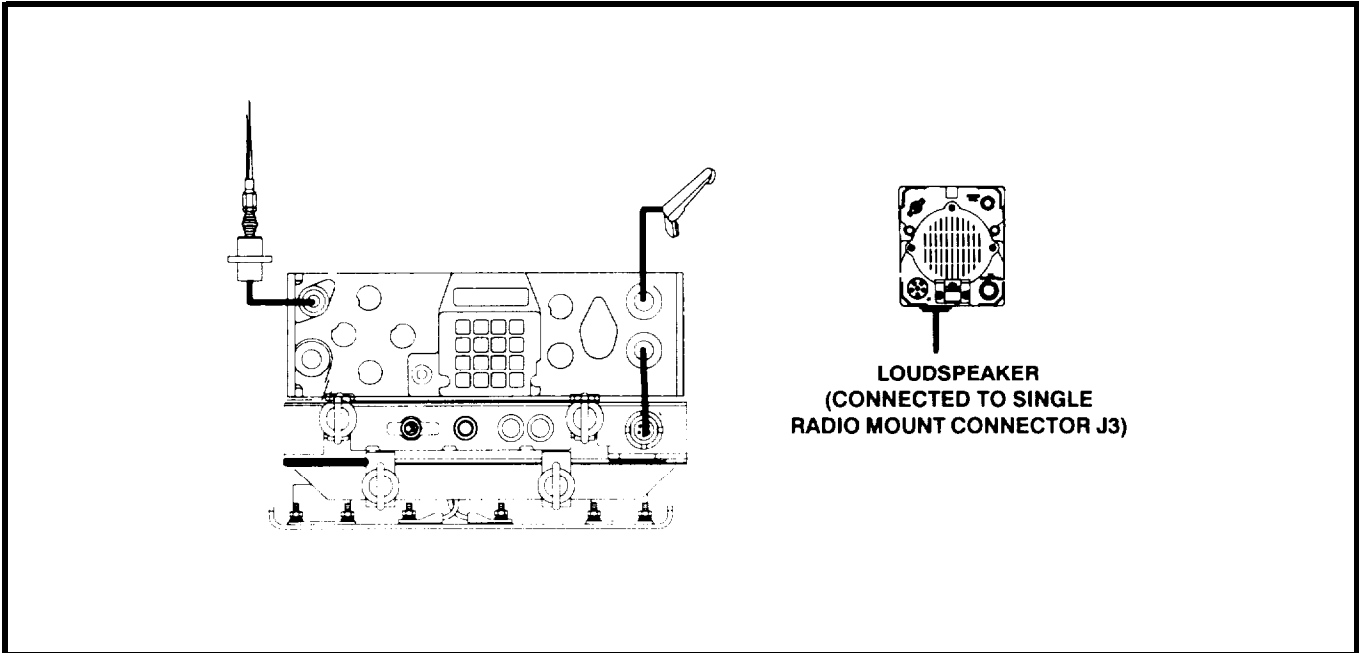

1. Receiver-Transmitter (FIT) (RT-1523/A\*/B).
2. Mounting Base, Electrical Equipment MT-6576 (SRM), part of installation kit.
3. Power Supply Adapter (PSA) (MX-10862).
4. Vehicular Antenna (AS-3900/3916), part of installation kit.
5. Handset (H-250), part of installation kit.
6. Loudspeaker (LS) (LS-671), part of installation kit.
7. Battery Tray (CY -8664) (selected configurations only), part of installation kit.
  - a. Battery Box (CY-8523A/B), installed in Battery Tray.
  - b. Battery (BA-5590), installed in Battery Box.
8. Cable (CX13314), connects RT to PSA.
9. Antenna Cable (CG-3856), part of installation kit.
10. Loudspeaker Cable (CX- 13292), part of installation kit.

\* RT-1523A versions with serial numbers below 20200 cannot be used with SRM configurations if either a VIC or LS-671 is used with that SRM radio.

**Figure 2-20. Components of Short Range Radio in Single Radio Mount (SRM)**

## 2.6b. Physical Data for Single Radio Mount (SRM) Radio

*NOTE: Weights are in kilograms; measurements are in centimeters. The numbers in parentheses show equivalent pounds and inches. All weights are approximate; all measurements are maximums.*

Table 2-10. Physical Data, Single Radio Mount Radios

ITEM	LENGTH	WIDTH	HEIGHT	WEIGHT
Mounting Base, Electrical Equipment, MT-6576 (SRM).	32.4 (12.8)	29.2 (11.5)	12.3 (4.8)	5.3 (11.5)
Power Supply Adapter (PSA), MX-10862.	29.8 (11.7)	27.4 (10.8)	12.6 (5.0)	4.1 (9.0)
High Voltage Center-Fed Antenna, AS - 3900	286.6 (112.8)	n/a	n/a	5.3 (11.6)
SINCGARS Low Profile Antenna (SLPA), AS- 3916.	209.9 (82.6)	n/a	n/a	2.4 (5.3)
Handset: H-250.	n/a	n/a	n/a	0.25 (0.55)
Loudspeaker (LS): LS-671.	10.6 (4.2)	12.6 (4.9)	16.0 (6.3)	1.1 (2.4)
Battery Tray, CY-8664 (Selected configurations only).	n/a	n/a	n/a	n/a
Receiver-Transmitter (RT), RT-1523	25.3 (10.0)	27.1 (10.7)	8.7 (3.4)	6.7 (14.7)
Receiver-Transmitter (RT), RT- 1523A	25.3 (10.0)	27.1 (10.7)	8.7 (3.4)	6.9 (15.2)
Receiver-Transmitter (RT), RT- 1523B	25.3 (10.0)	27.1 (10.7)	8.7 (3.4)	6.2 (13.7)

**2.6c. Performance Data for Single Radio Mount (SRM) Radio**

Table 2-11. Performance Data, Single Radio Mount Radios

TYPE COMM	RF PWR	RANGE*
VOICE	LOW (LO)	200 M to 400 M
VOICE	MEDIUM (M)	400 M to 5 KM
VOICE	HIGH (HI)	5KM to 10 KM
DATA 600-4800 BPS 16000 BPS	HIGH (HI)	3 KM to 5 KM 1 KM to 3 km

\* *Ranges shown are for planning purposes only. They are based upon line of sight and are average for normal conditions. Ranges depend upon location, sighting, weather, and surrounding noise level, among other factors. Use of the OE-254 antenna will increase ranges for both voice and data transmissions. Enemy jamming and mutual interference conditions will degrade ranges. In data transmissions, use of lower baud rate increases the range.*



**2.7. CONTROL, RECEIVER-TRANSMITTER (RCU) (C-11561 (C)/U)**

**2.7a. RCU Components**

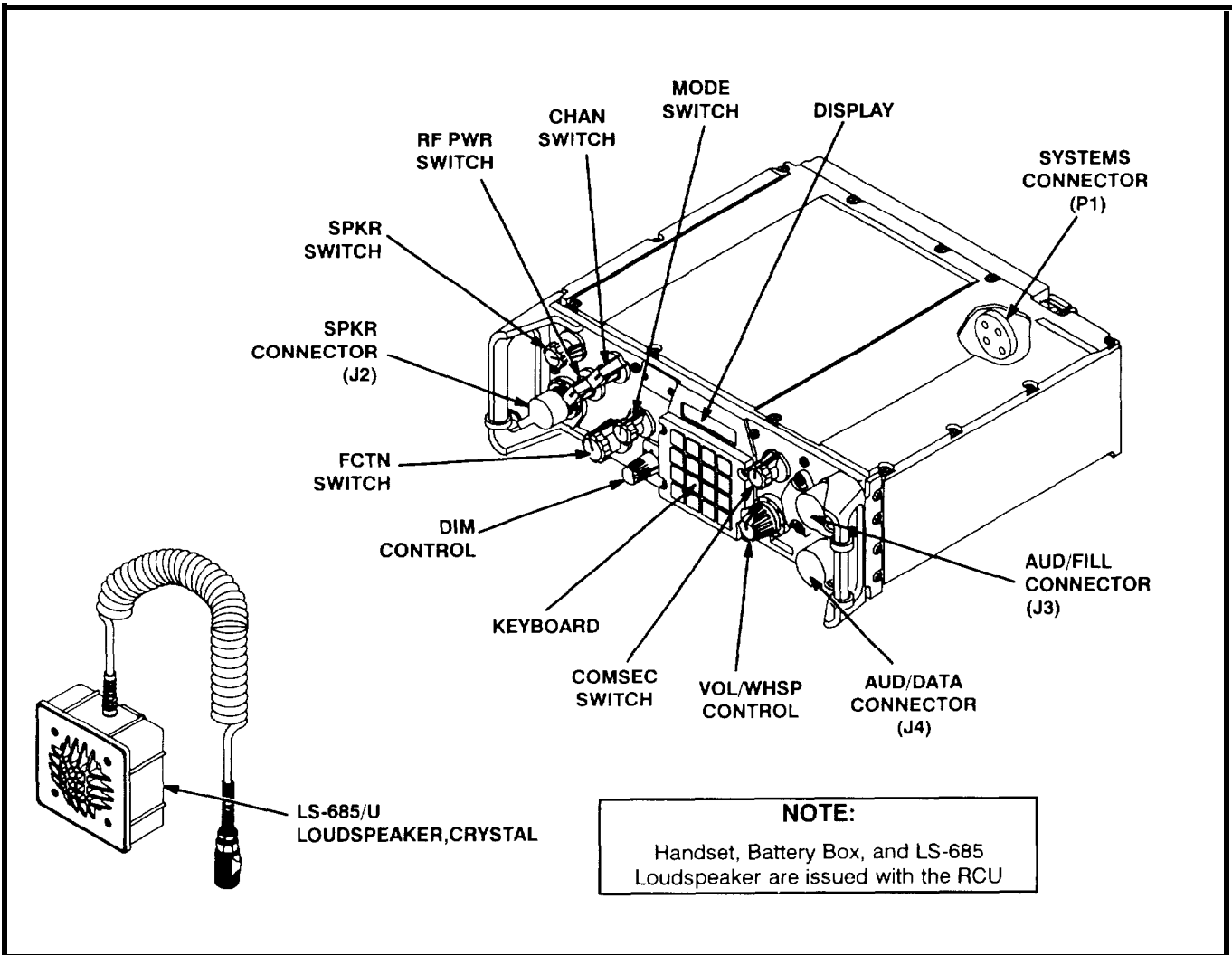

- |    |  |
|----|--|
| 1. | Control, Receiver-Transmitter, RCU (C-11561 (C)/U) |
| 2. | Battery Box (CY-8523A/B)                           |
| 3. | Handset (H -250)                                   |
| 4. | Loudspeaker (LS-685)*                              |

**Figure 2-21. Components of Control, Receiver-Transmitter (RCU)**

\* This is the only loudspeaker that can be used with the RCU speaker connector.

**2.7b. RCU Physical Data**

*NOTE: Weights are in kilograms; measurements are in centimeters. The numbers in parentheses show equivalent pounds and inches. All weights are approximate; all measurements are maximums.*

**Table 2-12. RCU Physical Data**

ITEM	LENGTH	WIDTH	HEIGHT	WEIGHT
<b>Control, Receiver–Transmitter (RCU) (C–11561)</b>	<b>25.3 (10.0)</b>	<b>27.1 (10.7)</b>	<b>8.6 (3.4)</b>	<b>7.0 (15.4)</b>
<b>Battery Box (CY–8523A/B)</b>	<b>23.4 (9.2)</b>	<b>8.5 (3.3)</b>	<b>12.8 (5.0)</b>	<b>1.4 (2.4)</b>
<b>Handset (H–250)</b>	<b>n/a</b>	<b>n/a</b>	<b>n/a</b>	<b>0.25 (0.55)</b>
<b>Loudspeaker (LS–685)</b>	<b>4.8 (1.9)</b>	<b>10.9 (4.3)</b>	<b>10.9 (4.3)</b>	<b>n/a</b>

**2.7c. RCU Performance Data**

**DISTANCE**

The RCU is connected to a SINGGARS radio by two-wire linkage (typically WD-1 field wire). The RCU may be located up to 4 kilometers away from the radio being remotely controlled.

**CAPABILITIES**

The RCU sends to and receives from its companion SINGGARS radio voice and data messages in either single channel or frequency hopping mode, and in plain or cipher text.

**INTERCOM**

A voice intercom capability is provided between the RCU and radio operators.

**RANGE**

Operating ranges of SINGGARS radios that are remotely controlled by an RCU are the same as the bracketed ranges shown for various radio configurations in paragraphs 2.3d and 2.51.

**2.8. CONTROL-MONITOR (C-M) (C-11291A)**

**2.8a. C-M Components**

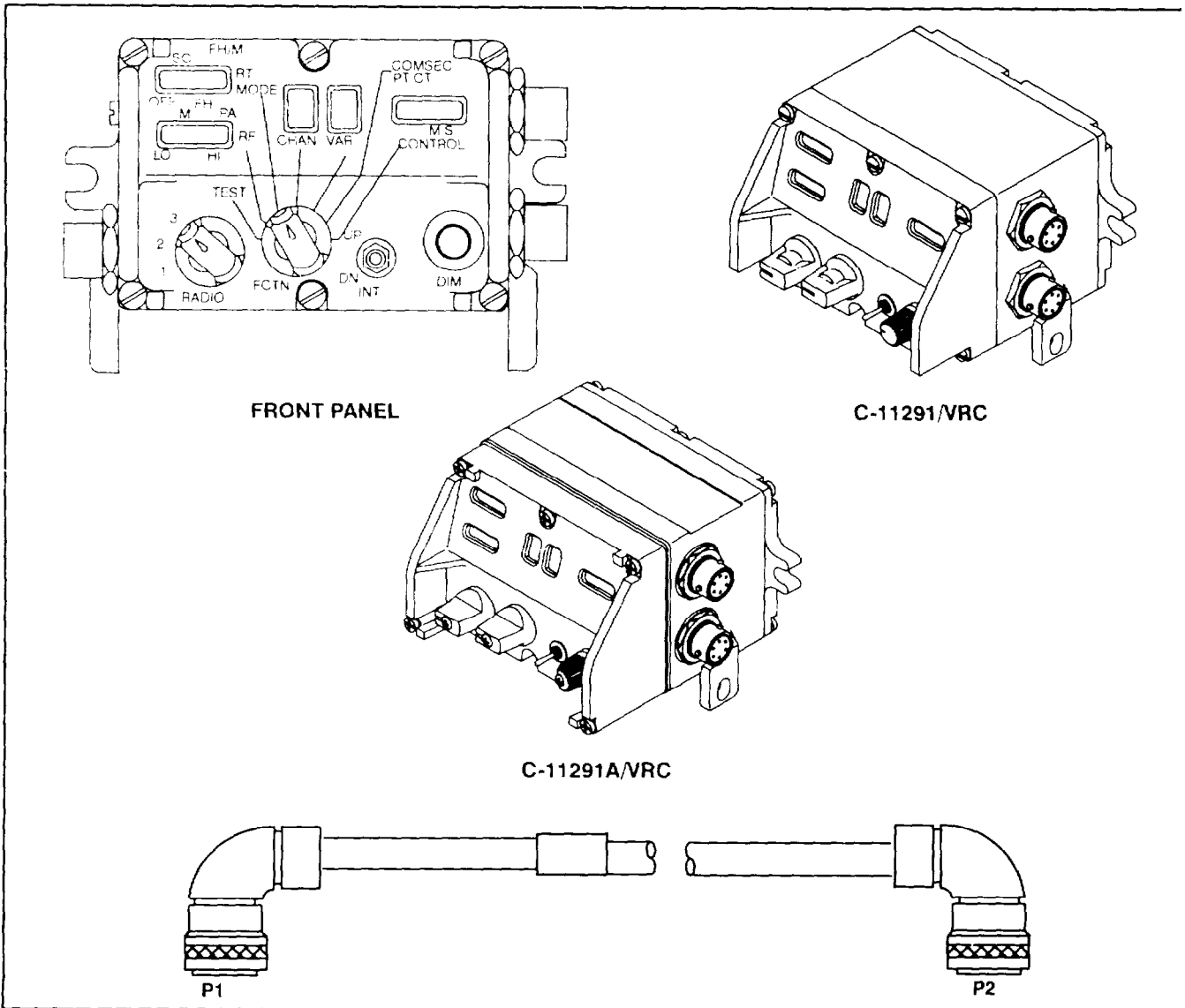

- 1. Control-Monitor (C-11291)
- 2. Cable (CX-13290), connects C-M to VAA.

Figure 2-22. Components of Control-Monitor (C-11291)

**2.8b. C-M Physical Data**

*NOTE: Weights are in kilograms; measurements are in centimeters. The numbers in parentheses show equivalent pounds and inches. All weights are approximate; all measurements are maximums.*

**Table 2 -13. Control - Monitor Physical Data**

ITEM	LENGTH	WIDTH	HEIGHT	WEIGHT
<b>Control-Monitor (C-11291)</b>	11.8 (4.6)	15.1 (5.9)	10.1 (4.0)	1.4 (3.0)
<b>Cable(s) (CX-13290) (2, 9, 15, 22 feet in length)</b>	n/a	n/a	n/a	n/a

**2.8c. C-M Performance Data**

- RADIOS** One Control-Monitor (C-M) can control up to three radios mounted in vehicular amplifier adapters (VAA). A three-position switch controls radio selection.
- FUNCTIONS** The Control-Monitor may be used to control radio RF Power, RT Mode, Channel, COMSEC keys, and active/standby status of C-M.
- SELF -TEST** A built-in self-test enables the Control-Monitor to check its control functions through proper manipulation of C-M controls.
- RADIO CAPABILITIES** Capabilities of the radios controlled by a Control-Monitor are the same as those for any SINCGARS radio.

**2.9 LOUDSPEAKER (LS-671)**

**2.9a. LS-671 Components**

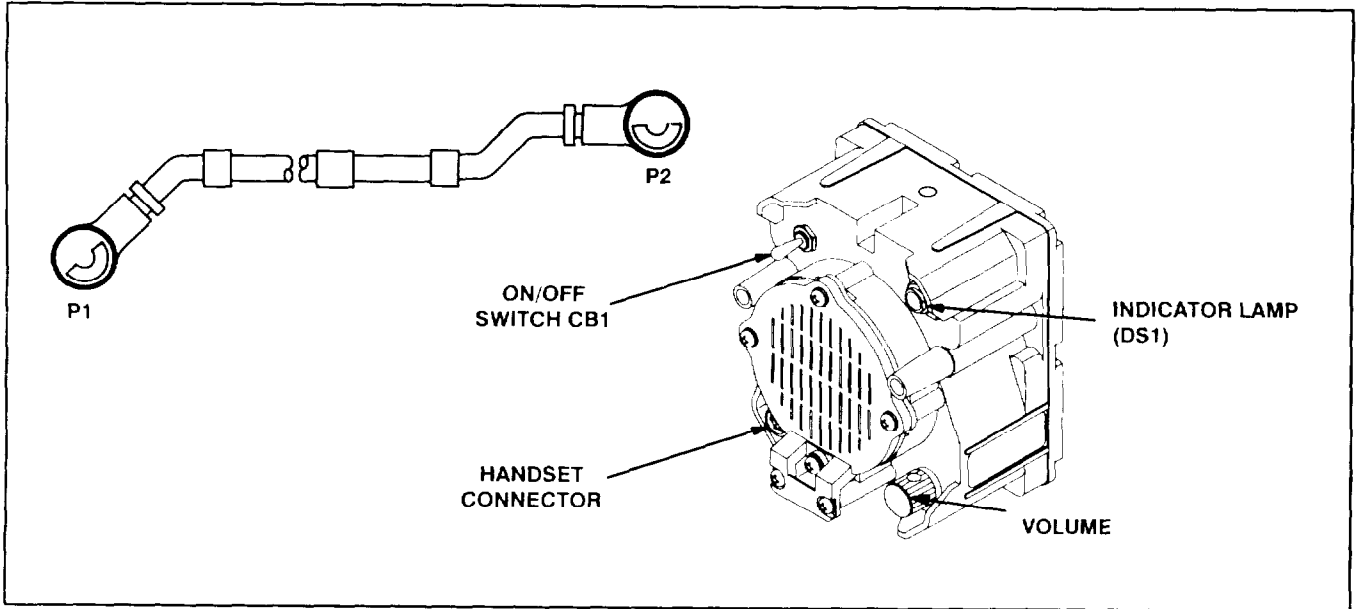

- |    |  |
|----|--|
| 1. | Loudspeaker (LS-671)                           |
| 2. | Cable (CX-13292), connects loudspeaker to MB.* |

Figure 2-23. Components of Loudspeaker (LS-671)

**2.9b. LS-671 Physical Data**

NOTE: Weights are in kilograms; measurements are in centimeters. The numbers in parentheses show equivalent pounds and inches. All weights are approximate; all measurements are maximums.

Table 2-14. LS-671 Physical Data

ITEM	LENGTH	WIDTH	HEIGHT	WEIGHT
Loudspeaker (LS-671)	10.6 (4.2)	12.6 (4.9)	14.6 (5.8)	( E )
Cable* (CX-13292) (Length of 3 to 100 feet)	n/a	n/a	n/a	n/a

\* Cable ends are marked "RADIO" and "SPEAKER." They can be reversed physically, but the radio/LS-671 will not operate. Be sure LS-671 cable is properly installed.

**2.9c. LS-671 Performance Data**

<b>PURPOSE</b>	Used to transmit and receive voice communications in vehicular radio configurations.
<b>POWER SWITCH</b>	Used to turn the loudspeaker on and off. May also be used to turn radio power on and off when VAA CB1 is set to ON.
<b>POWER INDICATOR</b>	Lamp lights when power switch is set to ON.
<b>HANDSET CONNECTOR</b>	Provides for connection of handset.
<b>VOLUME CONTROL</b>	Adjusts volume level of loudspeaker or handset. To adjust loudspeaker volume, pull control out and turn. To adjust handset volume, push control in and turn.
<b>J1 CONNECTOR</b>	Enables loudspeaker to be connected to mounting base or single radio mount using loudspeaker cable (CX- 13292).

## CHAPTER 3

### ASSOCIATED EQUIPMENT

**IN THIS CHAPTER:**

<b>3.1</b>	<b>AUTOMATED NET CONTROL DEVICE (ANCD) (AN/CYZ-10)</b> .....	<b>3-2</b>
	a. ANCD Capabilities .....	3-2
	b. ANCD Characteristics .....	3-3
	c. ANCD Physical Data .....	3-3
	(See TM 11-5810-394-14&P for detailed operating instructions)	
<b>3.2</b>	<b>PRECISION LIGHTWEIGHT GPS* RECEIVER (PLGR) (AN/PSN-11)</b> ...	<b>3-4</b>
	a. PLGR Capabilities .....	3-4
	b. PLGR Characteristics .....	3-4
	c. PLGR Physical Data .....	3-4
	(See TM 11-5825-291 -13 for detailed operating instructions)	
<b>3.3</b>	<b>FREQUENCY HOPPING MULTIPLEXER (FHMUX) (TD-1456/VRC)</b> ...	<b>3-5</b>
	a. FHMUX Components .....	3-5
	b. FHMUX Physical Data .....	3-5
	c. FHMUX Performance Data .....	3-6
<b>3.4</b>	<b>SECURE TELEPHONE UNIT (STU)</b> .....	<b>3-8</b>
	a. STU Capabilities .....	3-8
	b. STU Characteristics .....	3-8
	c. STU Physical Data .....	3-9
	(See manufacturer' s user manual for detailed operating instructions)	
<b>3.5</b>	<b>VEHICULAR INTERCOMMUNICATIONS SET (VIC) (AN/WC-1)</b> .....	<b>3-10</b>
	a. VIC Capabilities .....	3-10
	b. VIC Characteristics .....	3-10
	c. VIC Physical Data .....	3-11
	(See TM 11-5830-340-12 for detailed operating instructions)	
<b>3.6</b>	<b>HANDHELD REMOTE CONTROL RADIO DEVICE (HRCRD)</b> .....	<b>3-12</b>
	a. HRCRD .....	3-13

*\*Global Positioning System*

**3.1. AUTOMATED NET CONTROL DEVICE (ANCD) (AN/CYZ-10)**

**3.1 a. ANCD Capabilities**

<b>FUNCTIONS</b>	Capable of receiving, storing, and transferring data from ANCD to ANCD, from ANCD to SINCGARS radios, and from ANCD to other compatible communications/electronic equipment.
<b>PRIMARY USE</b>	The ANCD is used primarily for handling of COMSEC keys, FH data, sync time, and signal operating instructions (SOI) information.
<b>REPLACEMENT</b>	For SINCGARS applications, the ANCD replaces COMSEC devices such as KYK- 13, KYX- 15, and KOI- 18 as well as electronic counter counter-measure (ECCM) fill MX- 18290.
<b>DATA LOADS</b>	A typical ANCD data load at the operator level consists of two loadsets (COMSEC keys and FH data for all six radio channels), each good for 30 days of operation, plus 60 days of SOI information, structured in five ten-day editions, containing two 5-day sets each.
<b>CAPACITIES</b>	When used for a single or special purpose, an ANCD can store as many as 20 loadsets (COMSEC and FH data), and two or more division-wide editions (10 days each). The number of smaller unit SOI editions that can be stored in an ANCD depends entirely on the size of the SOI extract. An ANCD will also store as many as 120 COMSEC keys (traffic encryption key [TEK] or key encryption key [KEK]), or 280 transmission security keys (TSKs).

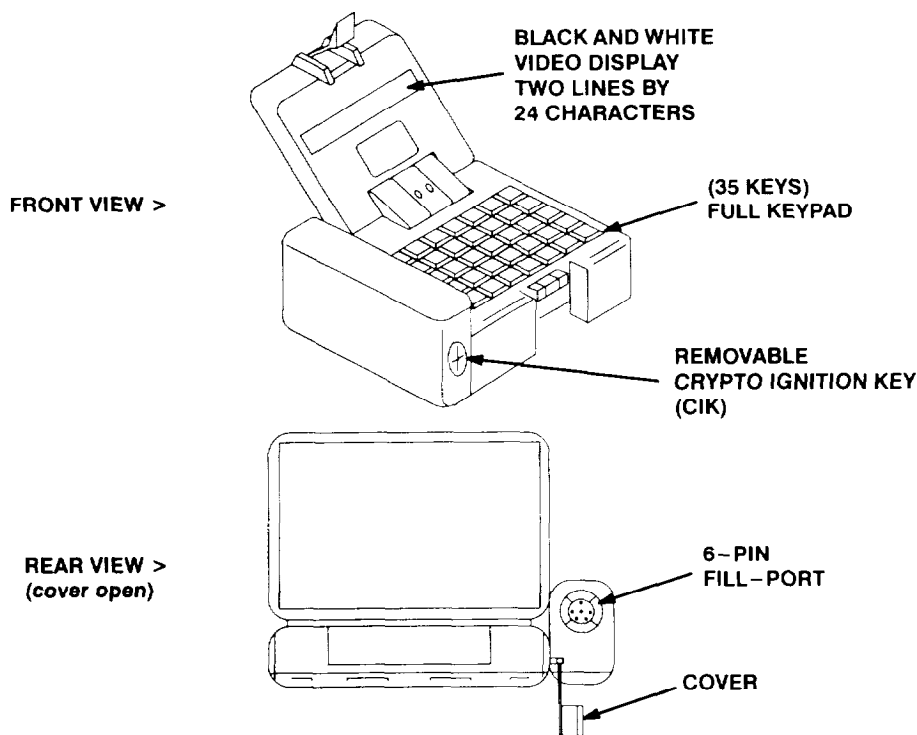

Figure 3-1. Automated Net Control Device (ANCD), AN/CYZ-10



<b>TRADE - OFFS</b>	When an ANCD is used for special data storage purposes, trade-offs between the above COMSEC/FH data and SOI capacities allow the ANCD storage capability to be tailored to specific unit requirements.
<b>MEMO</b>	The ANCD has the ability to receive, store, and transfer up to four short memos, each six lines in length, with 22 characters per line.
<b>OTAR</b>	Over-The-Air-Rekey (OTAR) operations, both Automatic Keying (AK) and Manual Keying (MK) Keying methods, are fully supported by the ANCD.
<b>BROADCAST</b>	The method of transmitting SOI information from one location to another electronically, known as "broadcast," is also fully supported by the ANCD.
<b>SECURE PHONE</b>	COMSEC keys, FH data, and SOI information can be sent from one location to another through use of the ANCD in conjunction with a Secure Telephone Unit (STU).
<b>PLGR</b>	The Precision Lightweight GPS Receiver (PLGR) can be loaded with the required operational key through use of the ANCD.

**3.1 b. ANCD Characteristics**

<b>HAND-HELD</b>	The ANCD is a hand-held electronic device.
<b>CASE</b>	The ANCD is housed in a weather-resistant case that provides a fill connector, cryptographic ignition key (CIK) port, and battery access cover as the only external openings.
<b>LID</b>	A hinged lid allows access to the ANCD LCD display.
<b>KEY PAD</b>	A 35- key keypad enables the operator receive, store, transfer, and use ANCD data.
<b>NIGHT VIEWING</b>	An internal ANCD lamp enables viewing of the display and keypad when night goggles are employed.
<b>BACKUP MEMORY</b>	The ANCD will retain stored data for up to two minutes to enable the operator to change batteries when required

**3.1c. ANCD Physical Data**

<b>MEASUREMENTS</b>	Length is 16.1 CM (6.3 IN).
	Width is 11.2 CM (4.4 IN).
	Height is 5.0 CM (2.0 IN).
<b>POWER</b>	The ANCD uses three 3-volt lithium batteries.
<b>WEIGHT</b>	With batteries installed, the ANCD weighs approximately 2 pounds.

**3.2. PRECISION LIGHTWEIGHT GPS RECEIVER (PLGR) (AN/PSN-11)**

**3.2a. PLGR Capabilities**

<b>LOCATION</b>	Through global positioning system (GPS) satellite contact, provides accurate location information in various formats.
<b>TIME</b>	Through global position system (GPS) satellite contact, provides accurate time in various formats and for various time zones.
<b>USES</b>	Primary use is to determine position location; secondary use is as the primary source of sync time used in SINCGARS radios.

**3.2b. PLGR Characteristics**

<b>ANTENNA</b>	The PLGR has a built-in antenna that can be swivelled to improve reception.
<b>KEY PAD</b>	The PLGR has a keypad with twelve multifunction keys that are used to control PLGR operation.
<b>DISPLAY</b>	The PLGR display contains four lines of information, with 16 characters per line.
<b>HANDLE</b>	A built-in, adjustable handle facilitates reading the PLGR display and making keypad entries while holding the device in the hand.

**3.2c. PLGR Physical Data**

<b>MEASUREMENTS</b>	Length is 24.1 CM (9.5 IN). Width is 10.4 CM (4.1 IN). Depth is 6.6 CM (2.6 IN).
<b>POWER</b>	For primary power, the PLGR uses a 6-volt lithium BA-5800 battery, and the memory battery is a 3.6-volt (LS-6) lithium battery.

**3.3. FREQUENCY HOPPING MULTIPLEXER (FHMUX) (TD-1456/VRC)**

The multiplexer combines any mix of up to four low to high power frequency hopping (SINGARS) transceivers to a single antenna. The FHMUX unit operates across the 30.000 to 87.975 MHz frequency range. The primary function is to extend the multiplexing capability to frequency hopping radios. In addition to the multiplexing function, the FHMUX prevents frequency collisions and provides the selectivity necessary to attenuate any local interfering signal which might otherwise result in degrading the receiver sensitivity. The FHMUX is digitally tuned via the SNAP interface when controlled by a SINGARS radio

**3.3a. FHMUX COMPONENTS**

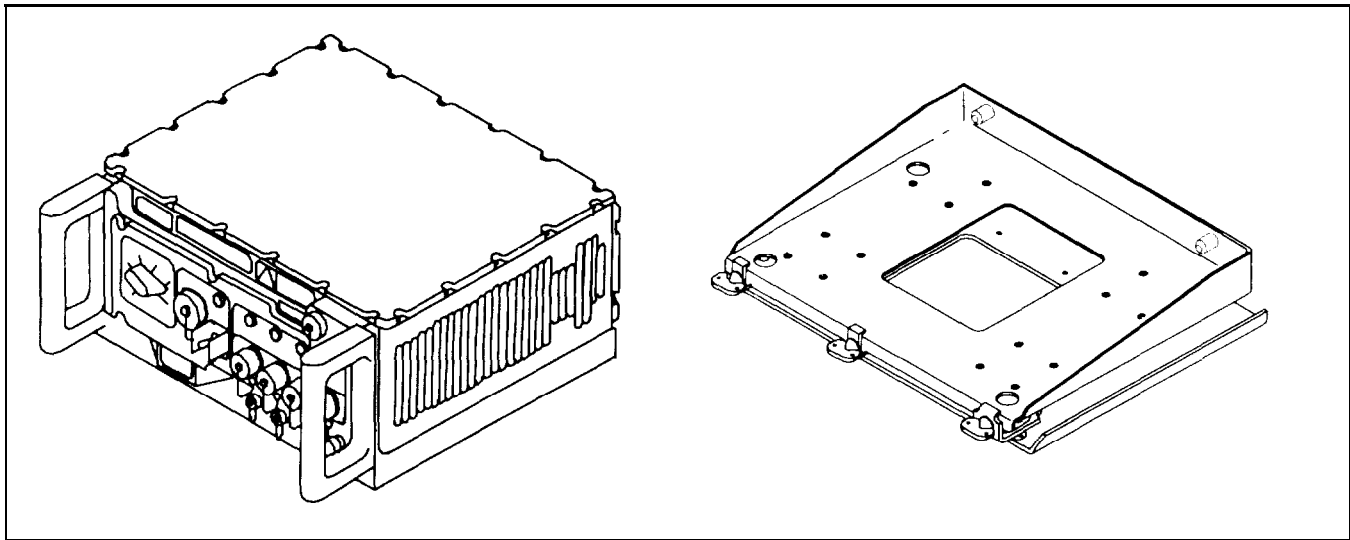

1. Multiplexer TD-1456/VRC (FHMUX)
2. Mounting Base

Figure 3-2. Multiplexer TD-145/VRC and Mounting Base

**3.3b. FHMUX Physical Data**

NOTE: Weights are in kilograms; measurements are in centimeters. The numbers in parentheses show equivalent pounds and inches. All weights are approximate; all measurements are maximums.

ITEM	LENGTH	WIDTH	HEIGHT	WEIGHT
Multiplexer	43.2 (17.0)	40.6 (16.0)	21.6 (8.5)	25 (56)
Multiplexer mounting base	40.6 (16.0)	41.4 (16.3)	8.9 (3.5)	8.6 (19)

**3.3c. FHMUX Performance Data**

**Vehicular Configuration**

Figure 3-5 shows a typical vehicular configuration using one multiplexer and two VRC-92A radios. The introduction of the multiplexer into the radio system is “transparent”, that is it does not affect the way the radios are operated. The number of vehicular antennas needed is reduced from four to one. Instead of each radio going directly to its own antenna, the antenna connections of the four radios are routed to the multiplexer and the multiplexer then connects to a single common antenna. To provide frequency hopping information to the multiplexer, the SNAP control signals provided by the VAA must be connected to the multiplexer, one SNAP cable per VAA. Vehicular DC power (22 to 32 Vdc) must also be supplied to the multiplexer through J2 on the Power Amplifier Mount (MT-6353/VRC) or through J2 on the Mounting Base (MT-6576/VRC).

The only two operator controls on the multiplexer are the POWER switch and the RADIO PRIORITY switch. The POWER switch must be placed in the ON position to use the FXMUX (the POWER switch can be turned ON and left ON if the DC power is controlled remotely by CB1 on the VAA).

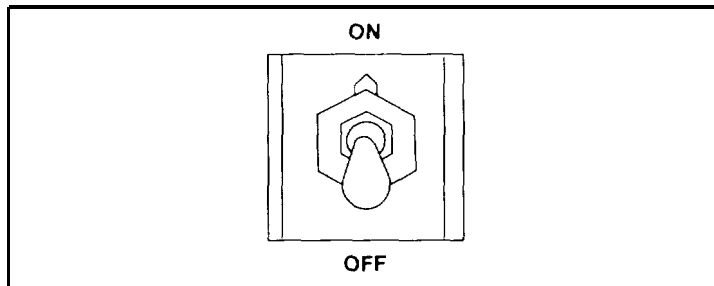

**Figure 3-3. POWER Switch**

The RADIO PRIORITY switch position is set based on the desired operating scenario. In the EQUAL position, all four radios connected to the multiplexer will have equal communications priority. In the 1A, 1B, 2A and 2B positions, the selected radio will have a slightly higher priority than the other radios whenever there is frequency conflict (a frequency conflict is when two or more hopping radios want to communicate on the same frequency at the same instant). In the RXMT(1A+1B) position, radios 1A and 1B (operating in the retransmit mode) have higher priority than radios 2A and 2B. Normally the switch will be set in the EQUAL position, but if desired, higher priority can be given to a critical communications link

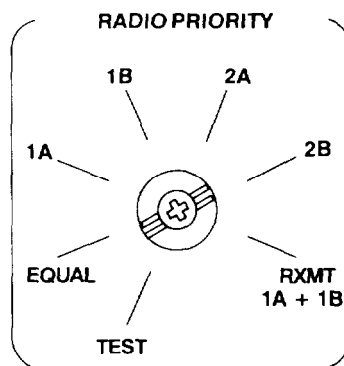

**Figure 3-4. RADIO PRIORITY Switch**

The TEST position is used only for Off -Line BIT and the switch should not be placed in this position except as directed in the -20 and -30 maintenance manuals.

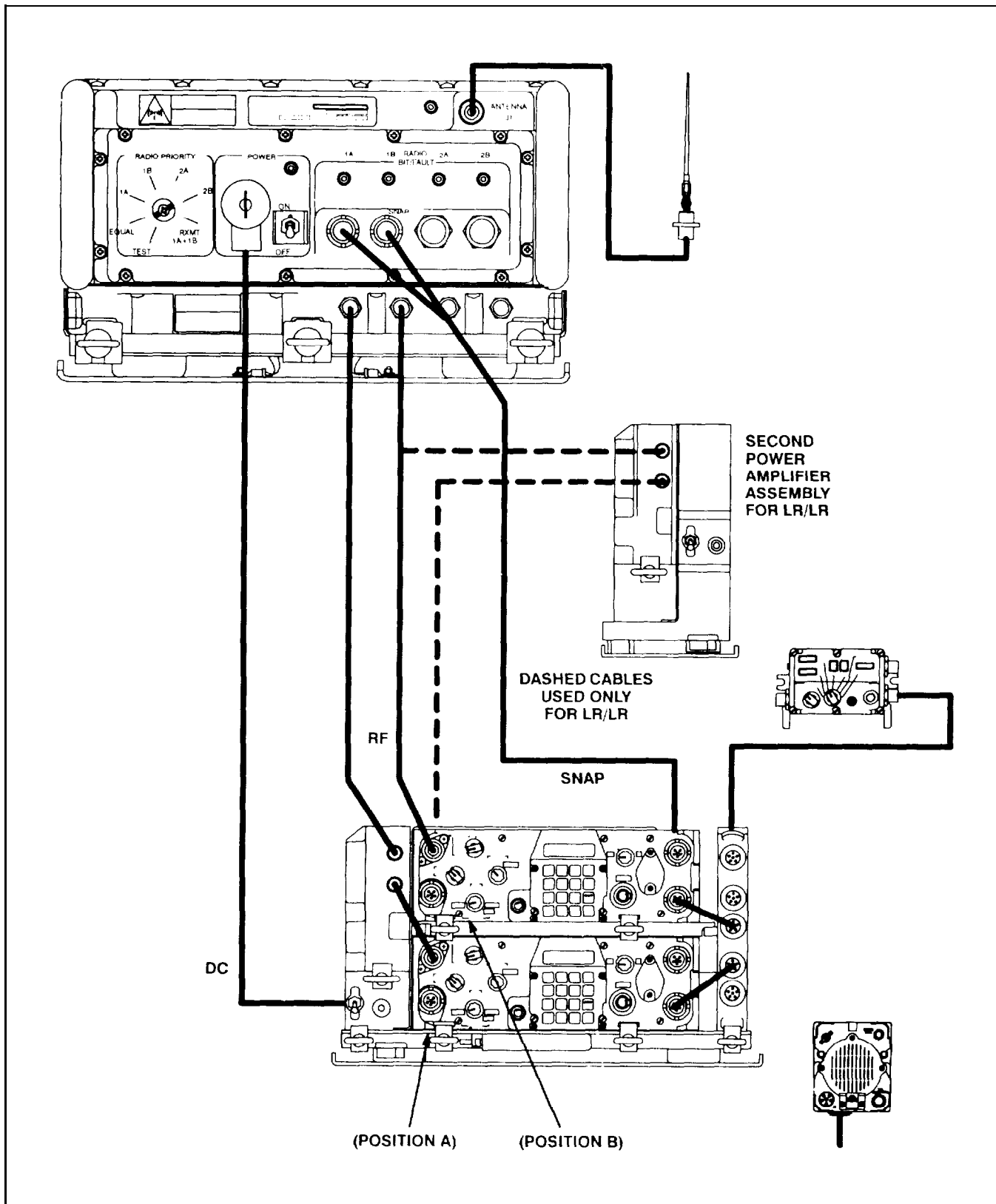

Figure 3-5. Dual Long/Long Range (LR/LR), two AN/VW-92s) with Multiplexer

### **3.4. SECURE TELEPHONE UNIT (STU)**

#### **3.4a. STU Capabilities**

<b>PURPOSE</b>	To enable secure (up to and including SECRET level of classification) voice and data transmissions to be performed over commercial and military telephone circuits.
<b>ANCILLARY DEVICES</b>	The ANCD may be connected to the STU to serve as the source of data and information to be transferred via telephone.
<b>APPLICATIONS</b>	COMSEC key, FH data (hopset/lockout, TSK, net ID), and SOI information may be sent over commercial and military telephone circuits, distance unlimited.
<b>DATA RECEIPT</b>	At the receiving end of the STU transfer operation, data is received by and stored in a target ANCD, available for use when required.
<b>AVAILABILITY</b>	STU equipment is provided primarily for peacetime, non-battlefield use, but it can be used whenever commercial or military telephone circuits are available. It is anticipated that STU transfer of SINCGARS-related key and data will be especially useful during mobilization as well as peacetime management of widely dispersed Reserve Component forces.

#### **3.4b. STU Characteristics**

<b>COMSEC</b>	Secure telephone units require use of proper COMSEC key.
<b>DATA RATES</b>	Synchronous data modes are at 2400, 4800, and 9600 BPS
<b>CIK</b>	Interoperable Cryptographic Ignition Key (CIK) allows the use of seven terminals.
<b>COMPATIBILITY</b>	STU is compatible with US commercial, DDN, and international telephone systems.
<b>TEMPEST</b>	STU meets requirements of NACSIM 5100A and is in compliance with MIL-STD-461B(RS03).
<b>COMMERCIAL</b>	The STU is a commercial off -the-shelf item and is not designed for outdoor, all-weather use.

**3.4c. STU Physical Data****MEASUREMENTS**

Height is 6.4 CM (2.5 IN).

Width is 22.9 CM (9.0 IN).

Depth is 25.4 CM (10.0 IN).

**POWER**

Uses 115 or 230 Vac, 50-60 Hz, at 20 W nominal consumption.

**BACK-UP POWER**

Uses a lithium, industry standard BR2325 battery to prevent loss of fill from power outage.

**WEIGHT**

3.6 KG (8.0 LB).

**TEMPERATURE**

Operating temperature ranges are 0 to 70 C (32 to 122 F).

**3.5. VEHICULAR INTERCOMMUNICATIONS SET (WC) (AN/VIC-1)**

**3.5a. VIC Components**

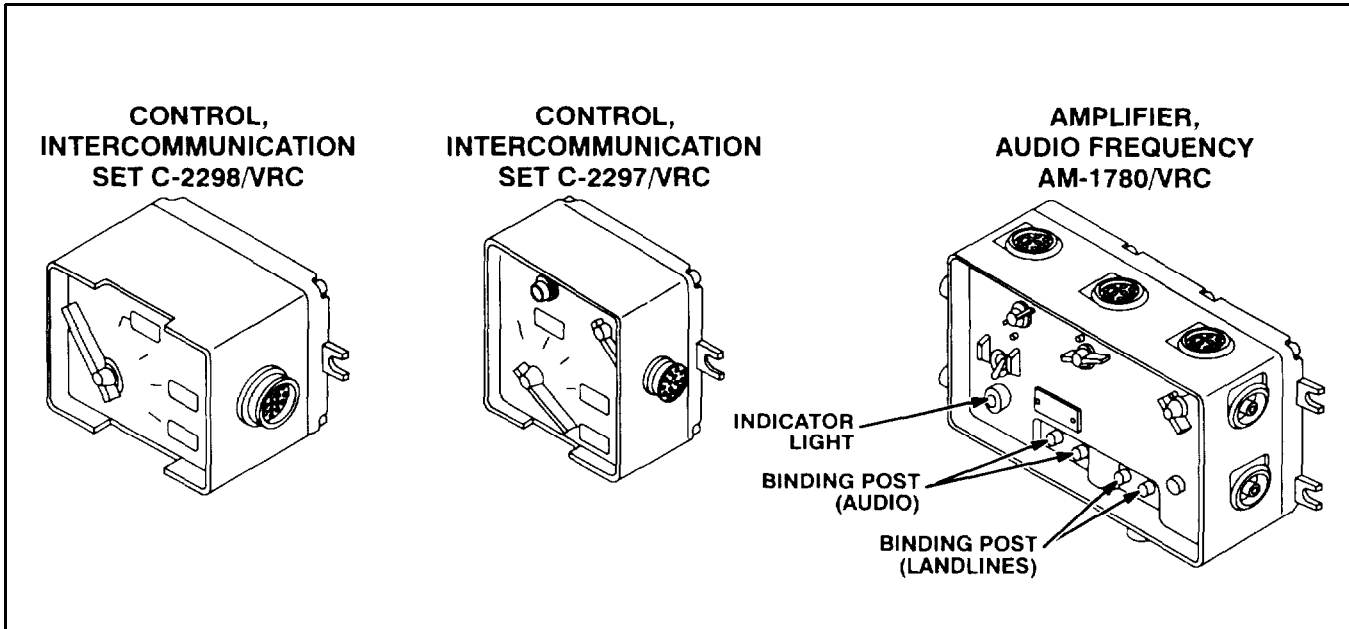

1. Audio Frequency Amplifier (AM- 1780)
2. Commander and Crewmember Control Box (C-2298)
3. Driver Control Box (C-2297)

**Figure 3-6. Components of AN/VIC-1 Intercommunication Set**

**3.5b. VIC Capabilities**

**AM-1780**

The audio frequency amplifier is the main junction box for the VIC-1 system. It provides control of DC power to associated control boxes and to the radio system connected to the AM-1780 amplifier. It also amplifies and controls audio signals in the intercom and radio circuits.

**C-2298/C-2297**

When a combat vehicle crew (CVC) helmet cord is connected to a control box, the crewmember can select, by means of the MONITOR switch and CVC controls, to communicate on the intercom or on a radio.



**3.5c. VIC Physical Data**

*NOTE: Measurements are in centimeters. The numbers in parentheses show equivalent inches. All measurements are maximums.*

**MEASUREMENTS  
(AM - 1780)**

Height is 9.6 CM (3.8 IN)

Depth is 14.6 CM (5.8 IN)

Width is 24.6 CM (9.7 IN)

**MEASUREMENTS  
(C-2297/C-2298)**

Height is 11.4 CM (4.5 IN)

Depth is 14.6 CM (5.8 IN)

Width is 8.9 CM (3.3 IN)

### 3.6. HANDHELD REMOTE CONTROL RADIO DEVICE (HRCRD)

The new Handheld Remote Control Radio Device (HRCRD), C-12493/U, is used with manpack radio AN/PRC-119A/D/F and the dismount kits of vehicular radio configurations AN/VRC-88A/D/F. The HRCRD enables the manpack operator to control the following functions of the radio using the HRCRD: Channel, RF Power, Mode, and COMSEC. For control of these functions, access to the manpack RT is not required. The operator can control the volume level of audio at the HRCRD by use of the thumb wheel located on the side of the device. Also, the operator can turn the NRCRD back light on and off by pressing the round light button. Operation of the HRCRD requires use of Battery Box, CY-8523C (for RT-1523C/D), which provides power from the main manpack battery to the remote control handset. The cable attached to the HRCRD forms a "Y" with one end connected to the RT AUD/DATA or AUD/FILL port and the other end to the 6-pin connector of Battery Box CY -8523C or AUX connector of the RT- 1523E.

Although the HRCRD is intended primarily for use with manpack radios, it can be used with vehicular configurations by connecting one end of the "Y" cable to the J9 port of the VAA. This will control the "A" radio only.

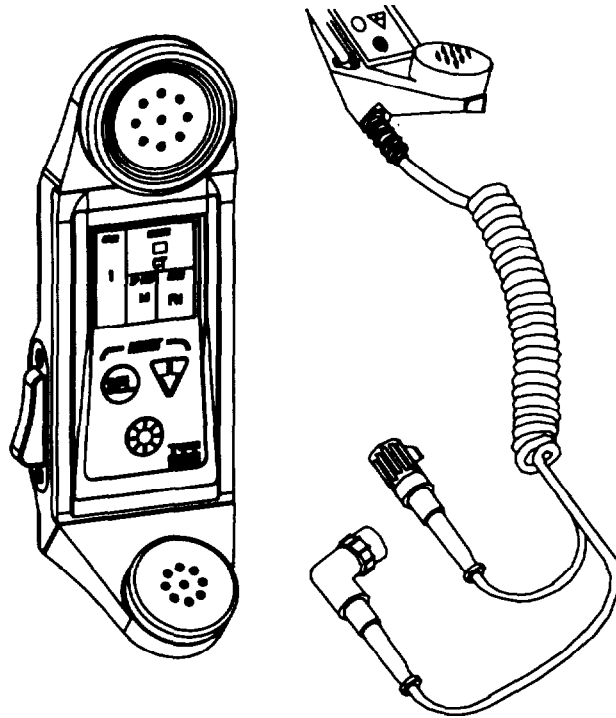

Figure 3-7. Handheld Remote Control Radio Device (HRCRD)

**3.6a. HRCRD****Cabling**

Connect the HRCRD “Y” cable ends to the RT AUD/FILL or AUD/DATA port and to the 6-pin connector on Battery Box CY-8523C or AUX connector of the RT-1523E. Only **Battery Box CY-8523C** may be used with the HRCRD.

**Controls**

To control radio functions, press [SEL] until the required function is highlighted (CHAN; COMSEC; RF PWR; MODE). Then press the [DOWN ARROW] until the specific item you need appears in the display. RT FCTN switch must be in REM for HRCRD to be functional.

**Light**

To turn the backlight on, press the light button. To turn the light off, press the light button a second time.

**Volume**

To change the level of audio volume, rotate the volume control knob on the side of the HRCRD to reach to level desired.

**Radio Controls**

For control of the other radio functions, make all the required selections and changes using the R keypad and front panel controls.

**Transmit**

Press the Push-To-Talk (PTT) switch on the side of the HRCRD.

**Receive**

Place handset near one end and adjust volume to required level for reception.

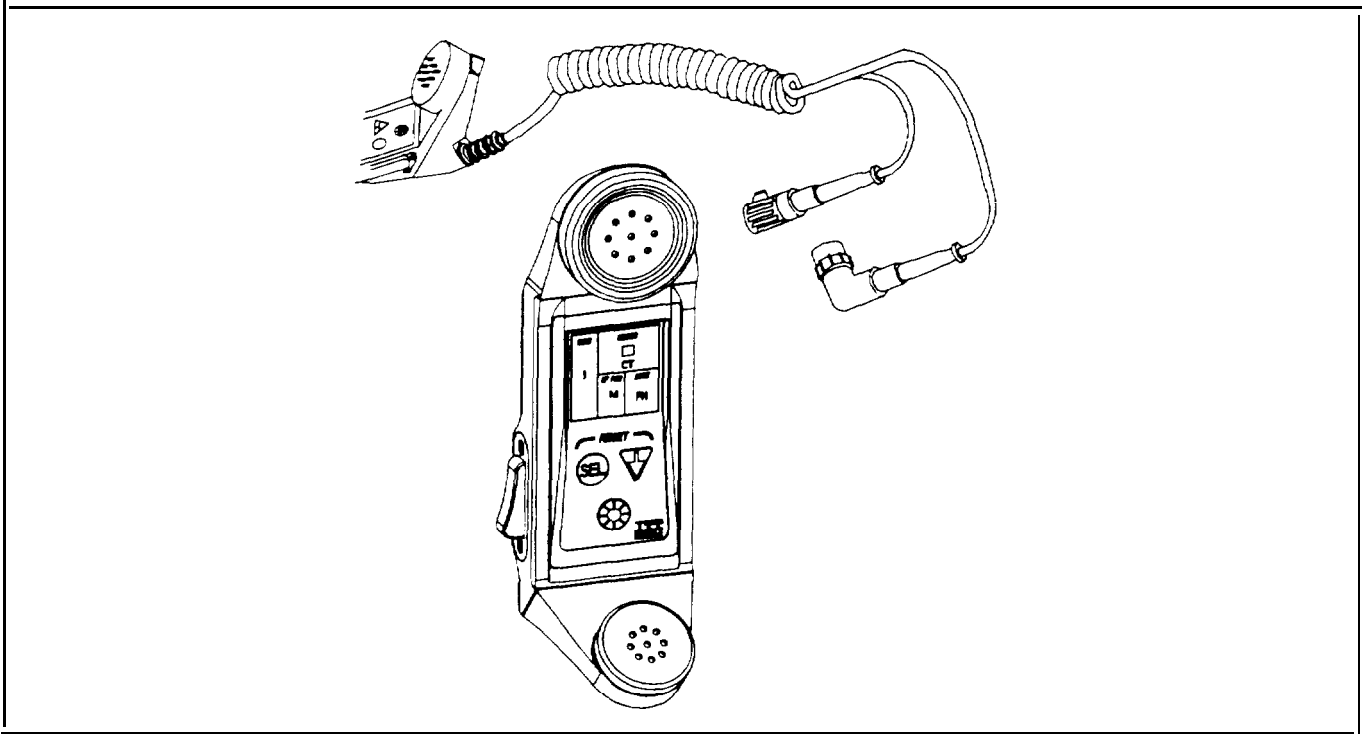

Figure 3-8. HRCRD Cables and Controls

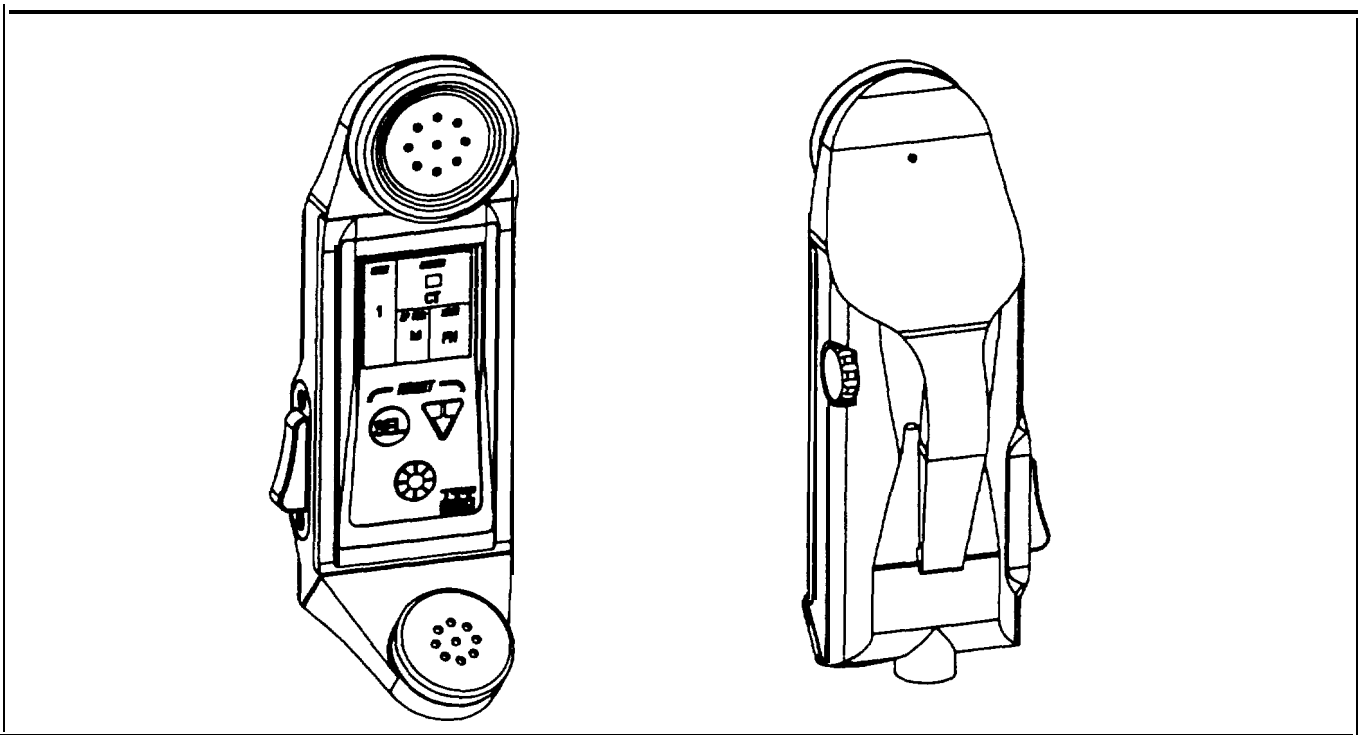

Figure 3-9. HRCRD, Front and Rear Views

# CHAPTER 4

## PRINCIPLES OF OPERATION

**IN THIS CHAPTER:**

4.1	<b>SECURE (CIPHER TEXT) (CT) COMMUNICATIONS</b> .....	4-2
	a. Integrated COMSEC (ICOM) .....	4-2
	b. Traffic Encryption Key (TEK) .....	4-3
	c. Cipher Text Operations .....	4-3
4.2	<b>SINGLE CHANNEL (SC) COMMUNICATIONS</b> .....	4-4
	a. Capabilities .....	4-4
	b. Limitations .....	4-5
	c. Required Usage .....	4-5
4.3	<b>FREQUENCY HOPPING (FH) COMMUNICATIONS</b> .....	4-6
	a. Capabilities .....	4-6
	b. Frequency Hopping Data .....	4-6
	c. SyncTime .....	4-7
	d. Advantages .....	4-9
4.4	<b>USE OF JULIAN DATE AND GPS ZULU TIME</b> .....	4-10
	a. Two-Digit Julian Date .....	4-10
	b. Precise GPS Time .....	4-11
	c. Common Zulu Time .....	4-11
	d. Cross-Net Communications .....	4-12
4.5	<b>NETOPENING</b> .....	4-13
	a. General .....	4-13
	b. Loadsets.. .....	4-13
	c. ICOM Fill of RT .....	4-15
	d. Hot Start Procedure .....	4-16
	e. Cold Start Procedure .....	4-17
4.6	<b>LATE NET ENTRY</b> .....	4-18
	a. General .....	4-18
	b. Passive Method .....	4-18
	c. Hot Start Option .....	4-19
	d. Reloading Sync Time .....	4-20
	e. CUE and ERF Method .....	4-21
4.7	<b>PERIODIC UPDATING</b> .....	4-22
	a. COMSEC Keys .....	4-22
	b. FH Data .....	4-22
	c. SOI Information .....	4-22
	d. SyncTime .....	4-22
	e. ANCD Loads and Updating .....	4-23

4.8	<b>ELECTRONIC UPDATING</b> .....	<b>4-24</b>
	a. Sending TEK by Over-The-Air-Rekey (OTAR) Procedures .....	4-24
	b. Sending FH Data by Electronic Remote Fill (ERF) Process .....	4-26
	c. Sending SOI Information by Broadcast Method .....	4-27
4.9	<b>RETRANSMISSION (RXMT) OPERATIONS</b> .....	<b>4-28</b>
	a. General .....	4-28
	b. RXMT Capability Modes .....	4-29
	c. RXMT Procedures .....	4-30
4.10	<b>ANTENNAS</b> .....	<b>4-32</b>
	a. Long Manpack Antenna (AS-4266A) .....	4-32
	b. SINCGARS Low-Profile Antenna (SLPA) (AS-3916) .....	4-33
	c. OE-254 .....	4-34
4.11	<b>REMOTING CAPABILITIES</b> .....	<b>4-34</b>
	a. Use of RCU .....	4-34
	b. Use of RT as RCU .....	4-40
	c. Use of LS-671 .....	4-41
	d. Use of Control-Monitor .....	4-42
	e. Use of Wire Line Adapter, HYX-57 .....	4-44
	f. Use of Remote Control Device, C2329/GRA-39 .....	4-45
4.12	<b>NETMANAGEMENT</b> .....	<b>4-46</b>
	a. Net Discipline .....	4-46
	b. Role of the NCS .....	4-47
	c. Role of Alternate NCS .....	4-47
	d. Special Task Performance .....	4-48
	Operator Proficiency .....	4-48
	f. MSE Compatibility .....	4-48
	g. Role of Signal Officers/NCOs .....	4-49

**4.1. SECURE (CIPHER TEXT) (CT) COMMUNICATIONS**

**4.1 a. Integrated COMSEC (ICOM)**

**BUILT-IN COMSEC**

SINCGARS ICOM radios have COMSEC capability built-in to the RT. All that is required to achieve secure, cipher text communications is to load the required COMSEC key.

**COMSEC ALARM**

The RT-1523/A/B COMSEC alarm (beeping sound) must be cleared by pressing PTT twice in order to load COMSEC keys or continue normal operations. The RT-1523C/D/E will generate a constant tone and display "NOKEY".

**PLAIN TEXT CALLS**

When a station operating in CT receives a call from a station using plain text (PT), the radio inserts a soft beeping alarm over the message to let the receiving operator know that the incoming message is not secure.

**4.1 b. Traffic Encryption Key (TEK)**

<b>KEY</b>	A traffic encryption key (TEK) enables the SINCGARS radio to operate in a secure, cipher text (CT) mode of communications. The TEK is loaded into the SINCGARS RT from an ANCD, or other COMSEC fill device, if desired.
<b>CHANNELS</b>	A TEK may be loaded into all six channels of the RT, or channel 6 may be reserved for OTAR use, covered below. Normally, the same TEK is loaded into all five or six channels, but any TEK may be loaded into any channel. If, for example, it is necessary to communicate with elements of a different division, you would load their TEK into the channel you intend to use for that purpose.
<b>COMPATIBILITY</b>	In order to communicate in secure, CT mode, both the transmitting and receiving radios must be using the same TEK. When using more than one TEK in your radio, it is important to record which channel each TEK is stored in.
<b>SCROLLING</b>	The SINCGARS radio offers the operator the ability to move TEKs from channel to channel. The process is called "scrolling," and it is easy to per-form. (For detailed procedures, see Figure 4-1, below.)

- |     |  |
|-----|--|
| (1) | Set CHAN switch to 1-5 (cannot scroll in chan 6), where different TEK is needed  |
| (2) | Press [CMSC] button; display shows TEK 1, TEK 2, etc.  |
| (3) | Press [CHG] button until TEK desired appears in display.   |
| (4) | Different TEK is now ready for use in channel selected.  |
| (5) | To return to original TEK, repeat steps (2) and (3), or move the CHAN switch out of and back into the operational channel. |

**Figure 4-1. HOW TO SCROLL TEK**

**4.1 c. Cipher Text Operations**

<b>PURPOSE</b>	The purpose of using secure, CT communications is to prevent the enemy from intercepting friendly traffic.
<b>POLICY</b>	Army policy calls for the use of CT mode whenever the capability is available.
<b>EASE OF USE</b>	With the built-in COMSEC feature of SINCGARS ICOM radios, ease with which all RT channels can be loaded with TEKs and the practice of using a common TEK throughout a division area makes secure communication quite easy to perform.

## 4.2. SINGLE CHANNEL (SC) COMMUNICATIONS

### 4.2a. Capabilities

#### DEFINITION

SINGGARS is a “single channel” radio in that it can transmit or receive on only one channel at a time. Single channel, or the SC mode of operation, refers to the fact that only one frequency is being used for communications.

#### FREQUENCIES

The SINGGARS radio will operate on 2320 different frequencies in the range of 30.000 to 87.975 MHz, with a 25 KHz separation between frequencies.

#### CHANNELS

Eight single channel frequencies can be loaded into a SINGGARS RT: one in each numbered channel 1-6, plus one each in the CUE and MAN channels.

#### LOADING

SC frequencies are loaded via the RT keypad. Although a matter of command policy, operators are normally required to load only those SC frequencies they are expected to need during mission operations. To load SC frequencies, use the procedure shown in Figure 4-2, below. (Also, see Primary Operator Task 1, “Load Single Channel Frequencies into SINGGARS RT.”)

- (1) Set FCTN switch to LD; MODE to SC.
- (2) Select CHAN 1-6, CUE, or MAN.
- (3) Press FREQ, then CLR.
- (4) Enter 5-digit frequency.
- (5) Press STO.
- (6) Repeat for each channel to be loaded.

Figure 4-2. HOW TO LOAD SC FREQUENCIES



#### **4.2b. Limitations of SC Communications**

##### **LOCATING**

When using the SC mode of communication, it is important to remember that an enemy with direction finding capability can pin-point your location. It may be necessary for you to move frequently, or limit transmission times, to avoid enemy action.

##### **JAMMING**

In that the SC mode uses only one frequency at a time to send or receive messages, the enemy may be able to jam your communications fairly easily.

#### **4.2c. Required Usage**

##### **COLD START**

To employ the Cold Start net opening procedure, it is necessary to use the MAN channel for sending and receiving the electronic remote fill (ERF) which contains FH data and sync time for frequency hopping operations.

##### **CUE PROCESS**

When an operator needs to enter an FH net and does not have the required FH data, or a radio with FH capability, it is necessary to “cue” (press PTT) on CUE channel or frequency with COMSEC set to PT. (For detailed procedure, see Figure 4-3, below.)

- (1) Calling operator sets CHAN to CUE; MODE to SC; COMSEC to PT; RF PWR to HI; presses PTT
- (2) Calling operator changes from PT to CT immediately after pressing PTT
- (3) This procedure is repeated about every 15 seconds until answer is received.
- (4) Receiving NCS sees “CUE” in RT display.
- (5) NCS changes to CUE, responds in CT
- (6) NCS directs caller to change to MAN.
- (7) On MAN chan, in CT mode, NCS determines what calling operator needs.

**Figure 4-3. HOW TO “CUE” AN NCS**

### **4.3. FREQUENCY HOPPING (FH) COMMUNICATIONS**

#### **4.3a. Capabilities**

<b>FREQUENCIES</b>	In the frequency hopping (FH) mode of operation, the SINCGARS radio transmits and receives on any or all of the 2320 frequencies, with 25 KHz separation, in the 30.000 to 87.975 MHz range. For best results, 1200 or more of the total 2320 frequencies are normally used.
<b>HOPPING</b>	In the FH mode, the SINCGARS radio uses, "hops on," over 100 frequencies per second.
<b>COMMUNICATING</b>	For two or more radios operating in the FH mode to communicate, it is essential that they contain the same set of frequencies and other variables, commonly referred to as "FH Data" .

#### **4.3b. Frequency Hopping (FH) Data**

<b>HOPSET</b>	Frequencies made available for a SINCGARS radio to hop on are called a "Hopset." A typical hopset consists of what remains of the total 2320 frequencies after protected frequencies, such as commercial television, are removed. Protected frequencies are frequently referred to as "Lockouts." In any case, except for technical purposes, lockouts are treated as an integral part of the hopset.
<b>TSK</b>	The pattern in which the radio selects frequencies to hop on is pseudo-random, as determined by the transmission security key (TSK). Depending upon the number of frequencies available for hopping and the TSK itself, the exact sequence of frequencies used during any one second will not be repeated for long periods of time.
<b>NET ID</b>	The remaining variable required for two or more frequency hopping radios to communicate is called the "Net ID." It is a three-digit number, 000-999, which controls where in the pseudo-random sequence the radio begins to hop.
<b>FH DATA</b>	In shot-t, the term FH Data refers to: Hopsets (with Lockouts integrated), TSK, and Net ID.
<b>COMMONALITY</b>	Typically, division-sized units use the same Hopset and TSK for all their SINCGARS frequency hopping nets. On the other hand, each net is assigned its own Net ID.

**4.3c. Sync Time****OTHER VARIABLE**

The remaining variable required for two or more frequency hopping radios to communicate is called "Sync Time." In addition to the FH Data elements discussed above, communicating radios must also have the same sync time, within plus or minus 4 seconds.

**RADIO CLOCKS**

In order to maintain proper sync time, the SINCGARS radio uses seven internal clocks, a base clock plus one for each of the six FH channels. MAN and CUE settings will display the base clock time.

**LOADING TIME**

For purposes of net opening, sync time can be loaded into the radio three ways: electronically from an ANCD or PLGR (RT-1523A/B/C/D/E only); manually through the RT keypad; or by receipt of a cold start net opening ERF. All three procedures set all seven clocks to the same sync time.

**CHANNEL TIME**

The plus or minus 4 seconds sync time requirement applies to each net individually. For example, if you are operating on Channel 1, and have proper sync time for that net, you cannot communicate on Channel 2 unless you also have the proper sync time for that net. With a separate clock for each channel, the radio allows for time differences greater than +/- 4 seconds among nets.

**CHANGING TIME**

Once your radio is operational in the FH mode, sync time can be changed in all seven clocks by the three methods discussed above. Sync time can be changed in a single channel, leaving other channels unchanged, only by receipt of an ERF and storing it in the channel to be changed.

**DANGER**

Nothing will take your radio OUT of a FH net quicker than changing sync time unintentionally. Normally, a SINCGARS operator loads sync time in preparation for net opening and does not touch the TIME button thereafter.

**NCS CONTROL**

The NCS radio, and only the NCS radio, uses the “FH-M” MODE position. In this mode, the NCS radio automatically brings the time of all net radios back into synchronization every time the NCS transmits. In short, when an operator is monitoring the operational net, there is little or no possibility that your radio will drift out of proper sync time.

**OTHER NETS**

Remember that the SINGARS radio can transmit or receive on only one channel at a time. In order to keep your radio in sync with nets other than your operational net, you need to check into or monitor each of the other nets at least once every 24 hours.

**COMMON SYNC TIME**

With the fielding of the Precision Lightweight GPS Receiver (PLGR), all units have been provided a ready source of highly accurate GPS time. By opening all nets on GPS time and updating NCS RT sync time to GPS time daily, all nets of a division, corps, or larger force are continuously kept within the +/- 4 second window required for FH communications. When common sync time is maintained, there is no need to enter or monitor another net to remain within that net’s sync time. Any net you need to enter, whether a part of your loadset or not, is readily available without concern for sync time.

**DIFFERENCES**

Operational differences in terms of sync time are shown in Figure 4-4, below.

RT VERSION	NORMAL COMM	PASSIVE LATE NET ENTRY	CUE AND ERF
RT-1523	+/- 4 seconds	+/- 1 minute	+/- 1 hour
RT-1523A	+/- 4 seconds	+/- 1 minute	up to 100 days
RT-1523B/C/D/E	+/- 4 seconds	+/- 1 minute	up to 100 days

**Figure 4-4. SYNC TIME OPERATIONAL DIFFERENCES**

**4.3d. Advantages****INTERCEPTION**

In addition to the built-in COMSEC capability of the SINCGARS radio, it confronts an enemy attempting to monitor friendly traffic with the rapid change of frequencies over a wide range. To intercept friendly traffic, an enemy must be able to match the FH data and sync time of the friendly net.

**JAMMING**

Jamming a SINCGARS FH net can be done, but only with extraordinary effort and commitment of equipment on the part of the enemy. Tests have shown that even when 30% of the FH channels have been jammed, a significant achievement, voice messages are still quite understandable.

**LOCATING**

Although it is relatively easy for an enemy with direction finding capabilities to accurately locate stations broadcasting in SC mode, experience has shown that it is nearly impossible to determine the location of an FH station.

**FREQUENCY SHARING**

SINCGARS hopsets, because of the rapidity of frequency hopping, can include frequencies used by single channel nets and mobile subscriber equipment (MSE). The frequency manager at division, corps, or higher headquarters ensures best overall usage of frequencies when developing hopsets.

**COMPATIBILITY**

SINCGARS radios will communicate with VRC- 12 Series radios, and similar radios of our Allies, in the SC mode. Also, the retransmission (RXMT) feature can be used as the interface between FH and SC nets when appropriate.

**UPDATE PERIODS**

Loadsets containing TEKs and TSKs are good to use for 30 days. ANCDs provide an additional 30 days of reserve data. In short, there is no requirement to update data for 30 days and then the unit has another 30 days to get their ANCDs reloaded with new data.

## **4.4. USE OF JULIAN DATE AND GPS ZULU TIME**

### **4.4a. Two-Digit Julian Date**

<b>DEFINITION</b>	Julian calendar days are normally numbered 1 through 365 or 366, with the year appended as a fourth digit.
<b>TWO-DIGIT DATE</b>	The SINCGARS radio uses a special two-digit form of Julian Date as a part of sync time. The two-digit Julian Date begins with 01 for 1 January and continues through to 00, repeating as necessary to cover the entire year.
<b>1 JANUARY CHANGE</b>	<p>In that the two-digit Julian year ends on 65, or 66 for leap year, every 1 January the Julian Date must be changed to 01. This can be done by:</p> <ol style="list-style-type: none"><li>(1) The NCS sending an ERF;</li><li>(2) Operators reloading time directly from an ANCD or PLGR; or,</li><li>(3) Operators manually changing the date in the radio by using the RT keypad.</li></ol>
<b>CONVERSION</b>	Dates displayed in the ANCD and PLGR take the form of Day-Month-Year (23-09-95). When these dates are loaded into a SINCGARS radio, they are automatically converted to the correct two-digit Julian Date needed by the radio.
<b>APPENDIX</b>	Appendix A to this manual provides two-digit Julian Date calendars for both regular and leap years.
<b>IMPORTANCE</b>	If your net were the only one operating in the FH mode, your NCS could select any two-digit date for net opening. Technically, the radio will work on any two-digit date. The importance of using the prescribed two-digit Julian Date is when there are other FH nets operating and you may need to contact them or they may need to contact you. Unless both nets have the same two-digit date as a part of sync time, they cannot communicate.

**4.4b. Precise GPS Time****IMPORTANCE**

As with the two-digit Julian Date, the importance of having the same accurate sync time in all FH radios is for cross-net communications. If only one net is involved, any time will do. If you want to communicate with nets you do not have loaded in your radio, having the same sync time is a big advantage.

**SOURCE**

Global Positioning System (GPS) satellites offer SINCGARS users very precise time by use of the Precision Lightweight GPS Receiver (PLGR).

**COMMON BASE**

When all FH nets are opened using precise GPS time, and when sync time of the NCS radio is checked against GPS time daily, all nets within a division or larger force are accessible by merely changing to the proper net ID.

**NO EXCEPTIONS**

With GPS time readily available to all SINCGARS NCSs and operators, there is no reason to use other than GPS time for SINCGARS sync time.

**4.4c. Common Zulu Time****IMPORTANCE**

Zulu time is commonly used for military message dating to provide a common basis of time around the world. Zulu time is used as basic SINCGARS sync time to ensure that all nets are using the same time, especially important when operating near a time zone boundary.

**AVAILABILITY**

The PLGR provides both local and Zulu time; either may be selected and read or transferred directly from the device.

**APPENDIX**

Appendix A to this manual provides a time zone map with Zulu time highlighted. For example, when Zulu time is 2400 hours, local time in New York is 1900, and in California it is 1600.

#### **4.4d. Cross- Net Communications**

**ONE NET ONLY**

Unless there is but a single FH net operating, a totally unrealistic battlefield situation, there is great advantage from the use of common sync time.

**FH- M POSITION**

The NCS radio automatically maintains sync time control (+/- 4 seconds) for that one net.

**RT CLOCKS**

With a separate clock for each FH operating channel, sync time is automatically maintained for your operational channel and the other four or five nets you have loaded into your radio.

**COMMANDERS**

Commanders, aircraft crews, and others who cross unit boundaries frequently have the need to be able to enter any net quickly and with minimum time and effort. If the net required is loaded in a channel of one of the operating radios, only the channel switch needs to be changed. If the net required is not loaded in one of the operating radios, and if all nets use common COMSEC, FH data, and sync time, only the net ID needs to be changed for secure FH communications to begin.

**MONITORING**

Monitoring, or "eavesdropping" as it is some times called, across all unit nets is essential to command and control on the modern battlefield. SINCGARS provides the capability to monitor or enter any net in the division so long as common COMSEC key, FH data, Julian Date, and GPS Zulu time are properly used.



## 4.5. NET OPENING

### 4.5a. General

#### NCS ROLE

The NCS of each net is responsible for opening the net at the time required to support unit operations. NCS net opening responsibilities include:

- Announcing the date-time of opening;
- Ensuring operators are provided the required COMSEC key and FH data loads;
- Sending an ERF if required; and,
- Logging members into the net during opening.

#### NET OPERATION

A SINCGARS secure, FH net will be opened prior to the start of an operation while the unit is still at home station or in an assembly area. It is highly unlikely the net, once operational, will ever be completely shut down until the exercise or operation has been completed. In combat situations, it would be rare for an entire net to shut down.

#### MINIMUM RT REQUIREMENTS

The minimum essential data required by a SINCGARS radio prior to net opening are COMSEC key and TSK. These data elements must be manually loaded into the radio even when an ERF is to be sent. Maximum data that can be loaded into the radio prior to net opening include COMSEC key, FH data, and sync time. In this case the radio is ready to enter the secure, FH net at the opening time or when called.

### 4.5b. Loadsets

#### DEFINITION

A "Loadset" is defined as all of the COMSEC keys (TEK and KEK) and FH data (hopset, TSK, and net ID) required to load all six channels of the SINCGARS radio.

#### UNIT-SPECIFIC

Loadsets are tailored to the needs of each net or unit, specifying by channel where the operational net will be and what other nets will be loaded into the remaining channels. For examples of company and platoon loadsets, see Figures 4-5 and 4-6, below. Unit loadset composition may be left to the discretion of each operator, but it is normally prescribed by the unit SOP to ensure that all operators have the same information and can readily contact other nets in the loadset.

CHANNEL 1	NET ID: 275	CO/TEAM COMMAND NET
CHANNEL 2	NET ID: 678	FIRE SUPPORT NET
CHANNEL 3	NET ID: 280	RIGHT FLANK CO/TEAM
CHANNEL 4	NET ID: 250	BN/TF COMMAND NET
CHANNEL 5	NET ID: 733	ATCHD ENGINEER PLT
CHANNEL 6	NET ID: 255	BN/TF ADMIN/LOG NET (OR KEK)*

Figure 4-5. EXAMPLE OF COMPANY LOADSET

CHANNEL 1	NET ID: 276	1 ST PLT
CHANNEL 2	NET ID: 277	2ND PLT
CHANNEL 3	NET ID: 278	3RD PLT
CHANNEL 4	NET ID: 275	CO/TEAM COMMAND NET
CHANNEL 5	NET ID: 678	FIRE SUPPORT NET
CHANNEL 6	NET ID: 733	ATCHD ENGR PLT (OR KEK)*

Figure 4-6. EXAMPLE OF PLATOON LOADSET

\* If a KEK is loaded in Channel 6 in preparation for use of OTAR procedures, Channel 6 may not then be used for either voice or data communications. Sending a TEK by OTAR procedures is normally an infrequent requirement, and Channel 6 requires FH data be loaded in order to send an OTAR message. One solution is to load a TEK in Channel 6, use it for normal communications until an OTAR requirement comes up, and then load a KEK from the ANCD into Channel 6.

**RESPONSIBILITIES**

Unit Signal Officers/NCOs are responsible for determining unit-specific loadset requirements and advising the brigade or separate battalion level Lightweight Computer Unit (LCU) operator of those requirements. The LCU operator, using the computer, assembles data into loadsets and distributes them to the using units.

**TF CHANGES**

When changes in task organization can be anticipated, revised loadsets are developed by the supporting LCU operator. When time does not permit LCU operator support, using units change net IDs as appropriate to accommodate changes in task organization.

**4.5c. ICOM Fill of RT**

**DEFINITION**

An ICOM fill is the loading of a loadset plus sync time from an ANCD into a SINCGARS RT (RT-1523A/B/C/D/E). (With RT-1523, sync time is loaded via the RT keypad.) As a result of an ICOM fill, all six channels of the radio are loaded with COMSEC key, FH data, and sync time. After an ICOM fill is performed, the operator needs only to call the NCS to enter the net.

**PROCEDURE**

Performing an ICOM fill is one of the basic tasks required of all SINCGARS operators. The procedure is simple and requires only the steps shown in Figure 4-7, below. (Also, see Primary Operator Task 2, "Load COMSEC/FH Data/Sync Time into Radio Using ICOM Fill.")

- |  |   |
|--|---|
| <ol style="list-style-type: none"> <li>(1)</li> <li>(2)</li> <li>(3)</li> <li>(4)</li> <li>(5)</li> <li>(6)</li> </ol> | <p>Turn radio and ANCD ON.</p> <p>On ANCD, select Radio, Send, Radio, and ICOM from the ANCD menu.</p> <p>Connect ANCD to the RT with proper fill cable.</p> <p>Set RT FCTN to LD; and COMSEC to CT</p> <p>Press [LOAD] button on RT</p> <p>All six RT channels are now loaded with COMSEC key, FH data, and sync time (if loading RT-1523A/B/C/D/E).</p> |
|--|---|

**Figure 4-7. HOW TO PERFORM AN ICOM FILL**

**4.5d. Hot Start Procedure**

**NCS REQUIREMENTS**

NCS requirements regarding the Hot Start net opening procedure are limited to setting the time of opening and ensuring that all net members receive the loadset to be used and correct sync time.

**LOADING THE RT**

The operator participating in a Hot Start net opening performs an ICOM fill (COMSEC key, FH data, and sync time) prior to the announced time of net opening. That is the only preparation the operator needs to make.

**NET ENTRY**

At the prescribed time for net opening, each net operator calls the NCS and enters the secure, FH net. The Hot Start net opening procedure is completed once all members have entered the net. An alternative procedure is for the NCS to call net members at opening time, but requirements remain the same. (See Figure 4-8, below, or Primary Operator Task 3, "Perform Hot Start Net Opening," for detailed procedures.)

- |   |
|---|
| <ol style="list-style-type: none"> <li>(1) Load RT using ICOM fill procedure.</li> <li>(2) Load sync time manually if required.</li> <li>(3) Call NCS and enter CT, FH net.</li> <li>(4) When all operators have entered the net, the Hot Start net opening is complete.</li> </ol> |
|---|

**Figure 4-8. HOT START NET OPENING**

**PREFERRED METHOD**

Because it is simple and easy to execute, the Hot Start method is generally preferred for net openings. A major advantage of the Hot Start procedure is that coordination requirements are minimized, and operators have maximum latitude regarding RT loading and net entry.

**SPECIAL MEMBERS**

The Hot Start procedure also recognizes that some operators, the commander's driver for example, may not be available at the announced net opening time. Such special operators can enter the net at whatever time they are available when Hot Start procedures are used.

4.5e. <b>Cold Start Procedure</b>
-----------------------------------

<b>FORMER PRIMARY</b>	Prior to the fielding of ANCDs and PLGRs, the Cold Start procedure was the primary method of net opening.
<b>NCS RESPONSIBILITIES</b>	The NCS is responsible for announcing the date-time of net opening, ensuring net members have all required COMSEC key and FH data, and for sending the net opening ERF.
<b>LOADING THE RT</b>	Net operators are required to load COMSEC key and FH data into their radios in preparation for the Cold Start ERF. Each receiving radio must have a TSK loaded in order to receive other required FH data by ERF
<b>SENDING THE ERF</b>	At the prescribed time, the NCS calls the net and announces that the net opening ERF will now be sent. To do so, the NCS merely retrieves appropriate data from the channel where it was stored and presses [ERF] on the RT keypad. (See Figure 4-9 below or NCS Primary Task 4 for detailed procedures.)
<b>RECEIVING THE ERF</b>	Receiving operators standby at the announced time with FCTN set to LD and MAN channel selected. When the ERF is received, operators will note the signal display jump and the RT display will show "HF XXX". The operator then presses [STO] followed by the channel number in which the ERF data is to be stored.
<b>ICOM FILL MINUS</b>	If operators use ICOM fill procedures for their Cold Start net opening preparations, but omit sync time, their radios will be fully operational once the ERF loads sync time into the base clock

- |     |  |
|-----|--|
| (1) | load SC frequency in MAN channel.  |
| (2) | load COMSEC key and FH data into RT  |
| (3) | Prepare radio to receive ERF: FCTN to LD, COMSEC to CT CHAN to MAN, MODE to FH.  |
| (4) | Standby for NCS to send ERF  |
| (5) | When ERF is sent, note sig display activate and display show "HF XXX."           |
| (6) | Press [STO] and channel number for storage.                                      |
| (7) | Set FCTN to SQ ON.   |
| (8) | Call NCS and enter the net, or wait for NCS call.                                |
| (9) | When all operators have entered the net, the Cold Start net opening is complete. |

**Figure 4-9. COLD START NET OPENING**

<b>SELECTIVE USE</b>	The Cold Start method of net opening is more demanding than the Hot Start procedure, but it can be useful in situations where the NCS desires to bring all operators into the net at the exact same time.
----------------------	---

## **4.6. LATE NET ENTRY**

### **4.6a. General**

#### **DEFINITION**

The term "Late Net Entry" means that the operator missed the announced net opening time and wishes to enter the net now, the operator left the net for some reason and now wants to re-enter, or sync time in the operator's radio now differs by more than +/- 4 seconds from that of the net.

#### **METHODS**

There are four ways in which an operator can perform a late net entry, each described below:

- (1) Passive method of late net entry;
- (2) The Hot Start option;
- (3) Reloading sync time option; and,
- (4) The CUE and ERF method.

#### **PREFERENCE**

All four methods are effective. The one to use is the one which best fits your situation.

### **4.6b. Passive Method**

#### **EASIEST**

When your situation will permit use of the Passive method, it is the easiest to use, requires minimum action on the part of the operator.

#### **BUILT-IN CAPABILITY**

The SINCGARS radio has a built-in capability to bring itself back into the +/-4 second window.

#### **SITUATION**

The typical situation where the Passive method is most useful is when the radio remains fully loaded with data but sync time has, for whatever reason drifted out of the +/-4 second window. It must still be within one minute of net sync time.

#### **PROCEDURE**

An indicator of the above situation is that no traffic is heard on the net for some period. The operator merely presses [FREQ] on the keypad, and then [SYNC]. The RT display shows "LF XXX". The operator then waits for traffic to be heard on the net, at which time the display drops the "L" and reads a normal "F XXX." At this point, time has been electronically brought back into sync, and the operator is back in the net. (See Primary Operator Task 4 for details.)

- |     |  |
|-----|--|
| (1) | Note lack of traffic on net.   |
| (2) | Press [FREQ] on RT keypad; display reads "F xxx."                                    |
| (3) | Press [SYNC] on RT keypad; display read "LF XXX."                                    |
| (4) | Wait to hear traffic on net; DO NOT PTT* (Note that "L" disappears from RT display.) |
| (5) | Your radio has brought you back into sync time; you are back in the the net.         |

**Figure 4-10. PASSIVE LATE NET ENTRY**

\* *If you PTT while your radio is in late net entry mode, your sync time will be thrown farther out of sync. (RT- 1523 only)*

**4.6c. Hot Start Option**

**NEXT EASIEST**

In this option, the operator connects the ANCD to the RT and repeats the ICOM fill procedure. It is easy to perform and takes very little time.

**SITUATION**

A typical situation where an operator would select this option is when the cause of being out of the net is uncertain. In short, the problem could be with data fill as well as with sync time.

**PROCEDURE**

The procedure is to select the proper menu items (four) on the ANCD, connect the ANCD to the RT, and press [LOAD] on the RT keypad. Sync time must be loaded manually if other than RT- 1523A/B/C/D/E is being used.\* Having repeated the ICOM fill, the operator merely follows Hot Start procedure and re-enters the net. (See Figure 4-8 or Primary Operator Task 3, "Perform Hot Start Net Opening," for detailed procedures.)

\* *If possible, check ANCD sync time against PLGR GPS time. If it has been more than 24 hours since GPS time was loaded into the ANCD, time difference may exceed +/- 4 seconds. In the worst case, load ANCD time and use passive late net entry.*

**4.6d. Reloading Sync Time**

**ALSO EASY**

This method calls for reloading of sync time, whether as a part of an ICOM fill, by electronic transfer from a PLGR, or through manually loading new sync time via the RT keypad.

**SITUATION**

The typical situation in which to use this method is again where the operator is reasonably certain that sync time is the problem. Another factor is that the operator may not be willing to wait for traffic to be heard (passive method) and elects this method to re-enter the net as quickly as possible.

**PROCEDURE**

There are three procedures by which sync time can be reloaded:

- (1) Repeat ICOM fill that includes sync time. Procedure is the same as that described in Figure 4-7 and Primary Operator Task 2, "Load COMSEC/FH Data/Sync Time into RT Using ICOM Fill."
- (2) Connect a PLGR to the RT and transfer GPS time. (See PLGR Task 3, "Load PLGR Date and GPS Zulu Time in SINCGARS RT," for detailed procedure.)
- (3) Determine correct GPS time from PLGR or ANCD, clear and load new Julian Date, clear and load new hours and minutes. Press [STO] at the time seconds are the same in the source device and the RT. Newly loaded sync time should be within one second of source time, otherwise try again. (See Figure 4-11, below, or Subtasks c and d of Primary Operator Task 3, "Perform Hot Start Net Opening," for detailed procedures.)

- |      |   |
|------|---|
| (1)  | Obtain running GPS time from ANCD or PLGR.  |
| (2)  | Press [TIME] on RT; display shows "DD."   |
| (3)  | Press [CLR] on RT; display shows "- _."   |
| (4)  | Enter correct Julian Date; display shows "XX."  |
| (5)  | Press [STO] on RT; Julian Date is stored.   |
| (6)  | Press [TIME] on RT; display shows "HH MM."  |
| (7)  | Press [CLR] on RT; display shows " _ _ _ _."  |
| (8)  | Enter GPS HH; display shows "HH."   |
| (9)  | Enter MM, the minute ahead of GPS time.   |
| (10) | When RT and GPS minutes are the same (zero seconds), press [STO] on RT.                 |
| (11) | If time stored in RT is more than one second different from GPS time, reload sync time. |
| (12) | Manual loading of GPS sync time is complete.  |

**Figure 4-11. CHANGING RT SYNC TIME**



4.6e. <b>CUE and ERF Method</b>
---------------------------------

**NOT SO EASY**

The CUE and ERF method of late net entry does work, but it requires much more of the operator than the other methods, described. It also requires action on the part of the NCS or alternate NCS, and it involves the use of SC transmissions with probable displacements following each.

**SITUATION**

A situation in which an operator may find it necessary to use the CUE and ERF method is when no net traffic is heard, data or sync time are believed to be at fault, and neither an ANCD nor a PLGR is available for reloading.

**PROCEDURE**

For the procedure to perform CUE and ERF method of late net entry, see Figures 4-12 and 4-13, below, or Special Operator Task 5, "Perform CUE and ERF Late Net Entry."

- |     |  |
|-----|--|
| (1) | Load CUE and MAN frequencies into RT   |
| (2) | Set CHAN to CUE, COMSEC to PT.   |
| (3) | Press PTT for 5 seconds (no need to talk).   |
| (4) | Set COMSEC to CT immediately.  |
| (5) | Wait for NCS to respond (repeat steps (2)-(4) every 15 seconds until a response is received. |

**Figure 4-12. OPERATOR' S CUE & ERF PROCEDURE**

*To respond to the operator' s CUE and ERF request, the NCS or alternate NCS, follows the procedure shown in Figure 4.13 (also see Primary NCS Task 5, " ' Respond to CUE Calls" :*

- |     |  |
|-----|--|
| (1) | Note "CUE" message in RT display.  |
| (2) | Switch from operational channel to CUE.  |
| (3) | Respond on CUE channel in CT mode.   |
| (4) | Direct caller to MAN channel.  |
| (5) | Upon caller' s request, send ERF on MAN channel.   |
| (6) | Return to operational channel, and check communications.   |
| (7) | Immediately displace to new location if enemy is believed to have direction finding capabilities. (Alt NCS normally responds to CUE calls to preclude NCS displacement.) |

**Figure 4-13. NCS CUE & ERF PROCEDURE**

**4.7. PERIODIC UPDATING**

**4.7a. COMSEC Keys**

TEK Traffic Encryption Key (TEK) must be updated (replaced) at least every 30 days.

KEK Key Encryption Key (KEK) must be replaced at least every 90 days.

**4.7b. FH Data**

HOPSET Hopsets do not require periodic change and may remain unchanged throughout an operation. Hopsets may change at any time because of operational requirements.

TSK Transmission Security Key (TSK) must be replaced at least every 30 days, the same frequency as TEK.

NET ID Net IDs do not require periodic change and normally remain unchanged throughout an operation. They may be changed at any time for operational reasons.

**4.7c. SOI Information**

DAILY The following SOI items change every 24 hours: call signs, suffixes, expanders, CUE frequency, MAN frequency, SC frequencies for channels 1-6, and sign/countersign.

10 DAYS Smoke and pyrotechnic signals change every 10 days

NO CHANGE Unclassified call words and their associated suffixes and expanders.

DEFINITIONS A five-day package of SOI information is called a set; a ten-day package is referred to as an edition.

**4.7d. Sync Time**

NO REQUIREMENT There is no requirement to periodically change sync time. The only requirement is to keep radios within a net, and nets within a command, on the same sync time.

OPERATIONAL The operational requirement calls for each NCS to once daily check RT sync time against GPS time. **If the difference is more than one second**, the NCS is expected to adjust the sync time in the NCS radio. Sync time in net member' s radios can then be updated by the NCS transmitting or merely pressing PTT several times. This sync time updating procedure ensures that cross -net communications are readily available to commanders and others who need them.

**4.7e. ANCD Loads and Updating**

<b>ACTIVE DATA</b>	Three SOI editions provide a using unit thirty days of SOI information for active use. One loadset provides the using unit with 30 days of COMSEC key and FH data.
<b>RESERVE DATA</b>	One reserve loadset provides the using unit 30 additional days of COMSEC key and FH data. Two reserve SOI editions provide SOI information good for the 30 days the active loadset is being used.
<b>ANCD LOAD</b>	By loading one active loadset (30 days), three active SOI editions (30 days), one reserve loadset (30 days), and two reserve SOI editions into unit ANCDs, there are three results. The unit has all the active data, loadset and SOI, it needs for 30 days. At the end of 30 days, the unit changes to the reserve loadset and the last SOI edition and continues to operate without interruption. The unit then has another thirty days during which to reload ANCDs with new loadsets and SOI editions in the same proportion.
<b>UPDATE CYCLE</b>	By making full use of the ANCD memory capacity, it is thus possible to minimize the impact of periodic updating on operational units. With an update requirement only every 30 days, and a thirty-day period in which to accomplish the update, there should be little or no impact on mission operations.

**4.8. ELECTRONIC UPDATING**

**4.8a. Sending TEK by Over-The-Air-Rekey (OTAR) Procedures**

<b>RESTRICTION</b>	Only TEK may be transmitted over the air using the OTAR procedure. KEK may be distributed by physical means only.
<b>TWO WAYS</b>	There are two procedures by which aTEK may be sent over the air. One is called Automatic Keying (AK); the other is Manual Keying (MK).
<b>MANUAL KEYING (MK)</b>	The MK OTAR procedure allows an NCS to transmit a TEK from a source ANCD, through the SINCGARS radios, to one or more target ANCDs. This is a useful form of OTAR in that the receiving NCS can then distribute the new TEK to net operators by passing the ANCD through the unit.
<b>AUTOMATIC KEYING (AK)</b>	The AK OTAR method transmits the new TEK from the NCS radio directly into the target operators' radios. An advantage of the AK method is that the receiving operator is required to take no action at all. A disadvantage is that the TEK and KEK in the receiving radios are changed immediately while the sending NCS must reload that radio with the new TEK and an updated KEK. This procedure involves some risk of losing communications, at least in secure mode.
<b>SENDING MK OTAR</b>	To send a new TEK to other NCSs by using the MK OTAR process, the sending NCS operator follows the steps shown in Figure 4-14, below (also see Special NCS Task 3, "Send TEK to Other NCSs Using MK Method of OTAR," for detailed procedures):

- |             |  |
|-------------|--|
| <b>(1)</b>  | Prepare radio to send MK OTAR: FCTN to SQ ON, MODE to FH-M, COMSEC to CT and DATA to OFF.            |
| <b>(2)</b>  | Load receiving stations KEK into NCS radios channel 6.   |
| <b>(3)</b>  | Prepare ANCD to send MK OTAR: turn ANCD ON, enter Radio, Comsec, MK, select TEK.                     |
| <b>(4)</b>  | Connect ANCD to NCS RT using fill cable.   |
| <b>(5)</b>  | Direct target NCSs to standby, make special NCS task 5 preparations, and ACK when ready for MK OTAR. |
| <b>(6)</b>  | Direct target NCSs to set RT to chan 6; press [RCV].   |
| <b>(7)</b>  | Set NCS RT to channel 6 and press [SEND].  |
| <b>(8)</b>  | Return to operational channel.   |
| <b>(9)</b>  | After 30 seconds, announce OTAR complete, TEK ID is xxxxx, effective DTG is xxxx, and obtain ACK.    |
| <b>(10)</b> | Reload KEK in NCS radio; MK OTAR is complete.  |

**Figure 4-14. SENDING MK OTAR**

**RECEIVING MK OTAR**

Target NCSs perform the steps shown in Figure 4-15, below (also see Special NCS Task 5, “Receive and Store TEK Sent by MK Method of OTAR,” for detailed procedures).

- |            |   |
|------------|---|
| <b>(1)</b> | Prepare radio to receive <b>MK</b> OTAR: FCTN to SQ ON, COMSEC to CT and DATA to OFF. |
| <b>(2)</b> | Prepare ANCD to receive MK OTAR: Turn ANCD ON, enter Radio, COMSEC, RV.               |
| <b>(3)</b> | Connect ANCD to RT; ACK to NCS when ready for MK.                                     |
| <b>(4)</b> | When directed, set RT to Chan 6; press [RCV] on ANCD.                                 |
| <b>(5)</b> | Return to operational channel.  |
| <b>(6)</b> | Enter Text ID; skip tag sequence.   |
| <b>(7)</b> | New TEK is now stored in target NCS ANCD ready for distribution when required.        |

**Figure 4-15. RECEIVING MK OTAR**

**SENDING AK OTAR**

To send a new TEK to net members by AK OTAR, the NCS will follow the steps shown below in Figure 4-16 (also see Special NCS Task 4, “Send TEK to Net Operators Using AK Method of OTAR”):

- |            |  |
|------------|--|
| <b>(1)</b> | Prepare NCS radio for AK OTAR: FCTN to LD, MODE to FH-M, COMSEC to CT and DATA to OFF.   |
| <b>(2)</b> | Prepare NCS ANCD to send AK OTAR: turn ON; enter Radio, COMSEC, and AK; select key.      |
| <b>(3)</b> | Alert operators to standby; press [SEND].  |
| <b>(4)</b> | Load AK OTAR TEK into NCS radio: select key and press [LOAD] / [STO]/[CHAN] on RT        |
| <b>(5)</b> | Update KEK used for AK OTAR: enter VU, select KEK; and press [RCV] on ANCD.              |
| <b>(6)</b> | Load updated KEK into NCS radio: enter text ID, Ld, and KEK; press [LOAD], [STO], and 6. |

**Figure 4-16. SENDING AK OTAR**

**FOLLOW UP ACTIONS**

The NCS sending an AK OTAR needs to do two things after sending the new TEK to net members. First, while the new TEK is automatically loaded into receiving station radios, it must be loaded from the ANCD into the NCS RT following the AK OTAR. Also, while the KEK in receiving radios is automatically updated, it must be updated by the sending NCS. (The NCS should always have his primary net’s KEK in his RT)

**RECEIVING AK OTAR**

Although sending an AK OTAR demands several actions on the part of the sending NCS, net operators need do nothing except stay off the PIT to receive the new TEK. Special features of the AK OTAR procedure are that the TEK in the operational channel of receiving stations is replaced electronically by the new TEK when the AK OTAR is sent. Also, the KEK in all receiving stations is automatically updated (changed) at the time the AK OTAR is sent.

**4.8b. Sending FH Data by Electronic Remote Fill (ERF) Process**

**ERF UPDATE**

Where the Cold Start ERF was sent on the MAN channel, an update ERF is sent over the operational channel.

**FH DATA UPDATE**

To replace the FH data being used in the operational channel, the sending NCS alerts net operations to standby, tells them in which channel to store the ERF, and sends it. The new FH data can be loaded in the operational channel only, or through sequential actions, into all channels.

**SENDING ERF UPDATE**

The procedure for sending an ERF update is as shown in Figure 4-17, below (also, see Special NCS Task 1, "Transmit Updated FH Data Via Net Update ERF"):

- (1) Load new FH data into RT.
- (2) Alert net operators for ERF, where to store it, and its effective DTG.
- (3) Net operators set FCTN to LD and standby for ERF.
- (4) NCS sets FCTN to LD; presses [LOAD] on RT; enters channel where new FH data is stored.
- (5) NCS presses [ERF] on RT, and returns FCTN switch to SQ ON.
- (6) Net operators standby, note activation of SIG display, press [STO] and channel number for storage.
- (7) NCS confirms net members receipt of the ERF.
- (8) At the time the new FH data is effective, NCS makes a communications check using new FH data.

**Figure 4-17. SENDING NET UPDATE ERF**

**4.8c. Sending SOI Information by Broadcast Method**

<b>DEFINITION</b>	Broadcast is a term used for transmitting SOI information over the air from one ANCD to another, using SINCGARS radios for transmission.
<b>LIMITATION</b>	Because of the amount of data involved in an SOI, normally no more than one time period of information is sent by the Broadcast method. This is not a limitation of the radio but a consideration that the radio is used for other purposes.
<b>DATA MODE</b>	The Broadcast method uses the 1200 bits per second data rate of the SINCGARS radio.
<b>PROCEDURE</b>	The procedure for sending SOI information by Broadcast Mode is as shown in Figure 4-18, below (also, see Special NCS Task 2, "Transfer SOI Information Using Broadcast Mode," for detailed procedure.)

- |     |  |
|-----|--|
| (1) | Set NCS RT to SQ ON, CT, FH-M, and DATA to 1200.   |
| (2) | Prepare ANCD for Broadcast: select SOI data to be sent; enter Broadcast, IDs of stations to be polled; and new SOI et name.              |
| (3) | Connect ANCD to AUD/DATA RT connector, and handset to AUD/FILL connector.  |
| (4) | Alert net operators to: Standby for Broadcast; go to SQ ON, FH, CT, and DATA at 1200.  |
| (5) | Direct net operators to: turn ANCD ON; enter SOI, Receive, Broadcast, station ID, connect ANCD to AUD/DATA connector of RT, and standby. |
| (6) | NCS presses [SEND] on ANCD; net operators press [RCV] on ANCD; SOI data is transmitted.  |

**Figure 4-18. SENDING SOI BY BROADCAST**

<b>SPECIAL FEATURE</b>	Up to 16 stations may be polled during use of the Broadcast method. All stations receive the transmission, but the NCS may select by identity code those stations to be polled. At the end of the first transmission, the ANCD determines which stations did not receive the SOI data and rebroadcasts. After the third broadcast to polled stations, the ANCD reports to the sending NCS any stations which still have not received the SOI data. If the NCS does not desire to use this polling feature, it can be shut off by entering "0."
------------------------	--

**4.9. RETRANSMISSION (RXMT) OPERATIONS**

**4.9a. General**

**BUILT-IN CAPABILITY**

The SINCGARS radio has a built-in retransmission capability which requires only two radios and the addition of an RXMT cable (CX-13298) for operations. Any configuration of the ground ICOM radio can be used for retransmission. The two radios may be installed on the same vehicle, on two separate vehicles, or two manpack versions may be used. RXMT cables come in two lengths, 5 inches and 15 feet, to accommodate various radio configurations.

**CAPABILITY MODES**

There are three modes of retransmission when using SINCGARS radios: (Each is described below.)

- (1) Frequency hopping net to frequency hopping net.
- (2) Frequency hopping net to single channel net.
- (3) Single channel net to single channel net.

**RXMT SITUATION**

A typical situation requiring retransmission communications is used to illustrate the various modes and procedures. An NCS has lost, or is about to lose, contact with one of the net stations. This could be caused by distance or line of sight obstacles such as mountains between the two stations. Whatever the cause, the answer is to establish an RXMT station at a site that will enable the NCS (requesting station) and outstation to continue, or resume, communications. In Figure 4-19, below, note that the requesting NCS uses RADIO-A, the outstation uses RADIO-B, and the RXMT team uses RADIO-C and RADIO-D. In RXMT configuration, RADIO-A communicates with RADIO-B by passing traffic through RADIO-C, the RXMT cable, and

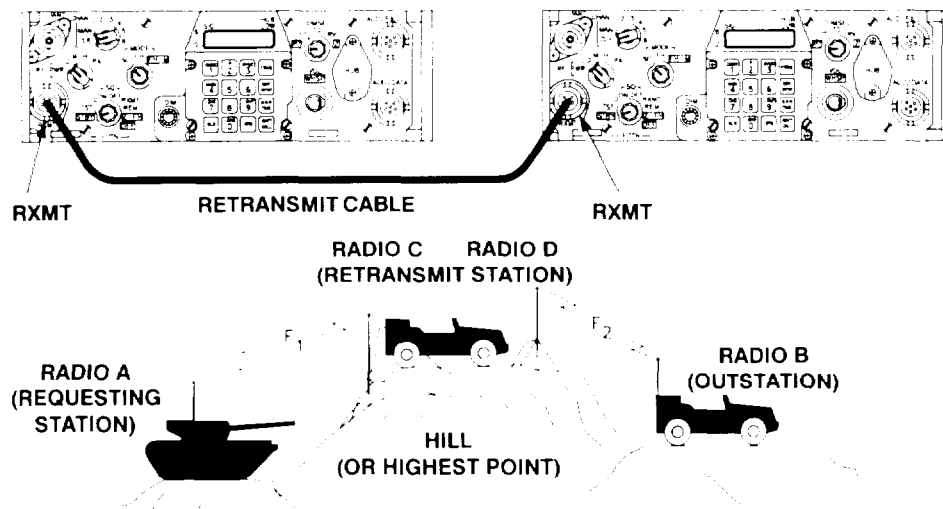

**Figure 4-19. RETRANSMISSION SITUATION**



#### **4.9b. RXMT Capability Modes**

##### **FH NET TO FH NET**

With extensive fielding of the SINCGARS radio, FH net to FH net RXMT links will probably be the normal mode of operation. RADIO-A and RADIO-C use the same FH data, including net ID. Communications between these two radios is no different than that between any two radios of the same net. RADIO-B, which is normally a member of this net, is out of range or has lost line of sight. In the FH to FH RXMT operation, RADIO-B and RADIO-D use a different net ID than that used by RADIO-A and RADIO-C. Use of the same hopset and TSK poses no problem. When the requesting station (RADIO-A) calls the outstation (RADIO-B) using one net ID, the message passes through RADIO-C and the RXMT cable to RADIO-D, which then sends the message to RADIO-B using another net ID. Other than a slight delay in transmission and the fact that distance and obstacles are overcome, there is no difference between direct and RXMT communications.

##### **FH NET TO SC NET**

It is anticipated that there will be both US and Allied Forces units equipped with SC only radios for some time. When it is necessary for a FH net to make contact or maintain communications with a unit using an SC net, RXMT can be useful regardless of distance or obstacles. In the FH to SC RXMT operation, RADIO-A and RADIO-C are frequency hopping, while RADIO-B and RADIO-D operate in the single channel mode. RADIO-A and RADIO-C use the same FH data; RADIO-B and RADIO-D use the same SC frequency. An FH message entering RADIO-D reaches RADIO-B as SC traffic. A SC message entering RADIO-C reaches RADIO-A as FH traffic.

##### **SC NET TO SC NET**

Although there should be little need for this mode of RXMT operation, it is available if required. In this case, RADIO-A and RADIO-C operate on a SC frequency that is at least 10 MHz different from that used by RADIO-B and RADIO-D.

##### **DATA SOURCES**

Net ID and SC frequencies used in RXMT operations are obtained from your SOI or unit SOP.

##### **ANTENNAS**

At the RXMT site, maximum results are attained by using two OE-254 antennas, separated as far as cabling will permit. The least satisfactory results will be obtained if two installed antennas on the same vehicle are used.

**4.9c. RXMT Procedures**

**NCS DESIGNATIONS**

In that the illustrative situation makes RADIO-A an NCS, RADIO-C will always operate in the FH position. Because RADIO-B is an outstation in RADIO-A's net, RADIO-B also operates in the FH mode. RADIO-D (an RXMT radio) operates in the FH - M position and serves as NCS for the two station net consisting of RADIO-B and RADIO-D.

**ELECTRONIC UPDATES**

OTAR and Broadcast transmissions Will pass through an RXMT installation, but ERF data Will not. If it is necessary to send net FH data to RADIO-B electronically, break the RXMT link, send the ERF to RADIO-D using one of the net IDs or SC frequencies. RADIO-D then sends the ERF to RADIO-B using the second net ID or SC frequency.

**NOTE**

RXMT MODE: When ASIP radios are used at the RXMT site and are temporarily taken out of the RXMT mode, the RXMT cable must be disconnected until the radios are placed back into a RXMT mode.

DATA RXMT: All data rates except PCKT may be retrains with the following provisions.

1, SDM data, TF and AD1 : No change to normal retrains procedures. Radios do not have to be set in Data mode (data off). Mixed radios at RXMT site or outstations is permitted.

2. EDM DATA: Radios at the RXMT site have to be set to the same EDM data rates as outstations. Only SIP/ASIP radios can be used at the RXMT site and outstations.

**COMSEC SETTINGS**

If using SINGARS versions RT-1523A/B/C/D/E, either PT or CT COMSEC setting may be used as desired. With a RT-1523 RXMT station FH-SC, only the RT in "SC" must be in PT. These requirements in no way preclude the use of CT communications between RADIO-A and RADIO-B. When the RXMT station must be in PT it will be necessary for RADIO-A or RADIO-B to change to PT if contact with the RXMT team is desired.

**FH TO FH PROCEDURE**

Procedures for establishing RXMT communications between RADIO-A and RADIO-B are as shown in Figure 4-20, below:

- |     |   |
|-----|---|
| (1) | NCS recognizes contact with RADIO-B is lost or soon will be; alerts RXMT crew for mission.  |
| (2) | RXMT crew loads radios with proper FH data, including RXMT net ID.  |
| (3) | RXMT crew moves to RXMT location, sets up OE-254 antennas, establishes RADIO-C to RADIO-A and RADIO-D to RADIO-B communications.  |
| (4) | When ready, installs an RXMT cable between RADIO-C and RADIO-D; sets RADIO-C and RADIO-D to RXMT sets RADIO-D to FH-M and RADIO-C to FH; and sets COMSEC of both radios to CT for monitoring. |
| (5) | RXMT communications between RADIO-A and RADIO-B are now established.  |

**Figure 4-20. FH NET TO FH NET RXMT**

**FH TO SC PROCEDURE**

The procedures for FH net to SC net RXMT communications are the same except that RADIO-D uses RADIO-B's SC frequency and may have to be placed in PT mode if the RT-1523 version of the SINCGARS radio is used.

**SC TO SC PROCEDURE**

The procedures for SC net to SC net RXMT communications are the same except that both RADIO-C and RADIO-D use SC frequencies, and both RXMT radios may have to be placed in PT mode if the RT-1523 version of the SINCGARS radio is used.

**SC DISADVANTAGE**

Whenever SC transmissions are required, there is the possibility that the enemy can locate the RXMT site by using direction finding techniques. In operational situations where the enemy is believed to have direction finding capabilities, an RXMT station should displace as frequently as necessary.

**EDM RXMT**

Operating in the EDM mode, any rate, a SIP/ASIP RXMT station will pass all EDM, SDM, and voice traffic. Both RXMT SIP/ASIP radios must be set to the EDM data rate being used by the operational net. When passing RS-232 traffic, the equivalent EDM data rate must be set in both RXMT radios.

**MIXED MODE**

Mixed mode (SC to FH, and FH to SC) cannot be used in the EDM mode. This is not a limitation because nets having SC only do not have EDM capabilities. When mixed mode RXMT communications are required, the solution is to use an SDM mode.

**4.10. ANTENNAS**

**4.10a. Long Manpack Antenna (AS-4266A)**

<b>SOURCE</b>	The long manpack antenna is issued as a component of the manpack and dismount radios. See Appendix B, this manual, for authorization details.
<b>EMPLOYMENT</b>	The long manpack antenna is designed to augment the short antenna in situations where additional range is required and your situation permits use of a long antenna.
<b>WARNING</b>	Before employing the long antenna during operations or training, be sure you understand the safety precautions.

**W A R N I N G**

**DEATH OR SERIOUS INJURY CAN OCCUR IF THE ANTENNA COMES INTO CONTACT WITH OVERHEAD POWER LINES**

*Never fully extend the long antenna directly under power lines. If you must fully extend the long antenna near power lines, power line poles or towers, or buildings with overhead power line connections, never come closer than two times the antenna height from the base of the power line, pole, tower or building.*

*Stop before you get close to the power line and check for clearance before passing. If needed, either carefully tie down the antenna or remove the antenna to make sure that you can safely pass under the power line.*

*When mission permits, use the short manpack antenna during operations on the move. If you must use the long antenna on the move, never pass under power lines if there is any doubt about overhead clearance.*

*For additional safety information, refer to T-B -43-0129, "Safety Requirements for Use of Antenna and Mast Equipment."*

**Figure 4-21. MANPACK LONG ANTENNA SAFETY PRECAUTIONS**

**4.10b. SINCGARS Low-Profile Antenna (SLPA) (AS-3916)**

<b>SOURCE</b>	The SINCGARS Low-Profile Antenna, or SLPA for short, is a part of selected vehicular radio installation kits. Refer to SB 11-131-2 for listings of individual kits.
<b>EMPLOYMENT</b>	The SLPA is designed to reduce antenna visibility, and it withstands tree limb strikes better than the regular antenna. There is a slight reduction in operating range of the radio when the SLPA is employed. Both regular and SLPA antennas are provided for selected combat vehicles, tanks for example.
<b>SAFETY</b>	Safety precautions pertaining to the employment of vehicle antennas are repeated here for sake of emphasis.

**W A R N I N G**

**DEATH OR SERIOUS INJURY CAN OCCUR IF THE ANTENNA COMES INTO CONTACT WITH OVERHEAD POWER LINES**

Do not stop your vehicle under power lines.

When mobile, never pass under power lines if there is any doubt about overhead clearance.

If you are not sure that an antenna on your vehicle will clear a power line, stop before you get close to the power line and either carefully tie down the antenna or, if necessary, remove the antenna to make sure that you can safely drive under the power line.

During cross-country operations, do not allow anyone to stick an arm, leg, or weapon over the sides of the vehicle. If your antenna accidently touches a power line, individuals who are in contact with vegetation or the ground could suffer death or severe injury.

for additional safety information, refer to TB-43-0129, "Safety Requirements for Use of Antenna and Mast Equipment."

**Figure 4-22. VEHICULAR ANTENNA SAFETY PRECAUTIONS**

**14.10c. OE-254**

**SOURCE**

The OE-254 antenna is not a part of the SINCGARS radio system and must be requisitioned separately. Refer to your MTO&E or TDA for the number authorized.

**EMPLOYMENT**

This extended range antenna may be used with any configuration of ground SINCGARS radios, including the manpack version. By both its height and design, the OE-254 helps to increase the operating range of any SINCGARS radio.

**DUAL USE**

When two or more OE-254 antennas are employed in the same location, a command post for example, they should be separated by the maximum distance permitted by cabling. When two OE-254 antennas are used with the same vehicle, as during RXMT operations for example, it is essential that they be separated as far possible.

**4.11. REMOTING CAPABILITIES**

**4.11a. Use of RCU**

**GENERAL**

The Control, Receiver-Transmitter (C-11561), or remote control unit (RCU) as it is commonly called, provides for remote control of SINCGARS radios for ranges up to 4 KM. The RCU is connected with the radio by two-way field wire, and its controls, features and operation are quite similar to those of the SINCGARS radio. SIP/ASIP RT can be used as a RCU (LS-685 cannot be used with SIP/ASIP RT

**SOURCE**

The RCU is a separate issue item, similar to a SINCGARS radio configuration. RCU details and components (battery box, handset, and LS-685 loudspeaker) may be found in Appendix B to this manual.

**COMSEC**

Both the RCU and RT use a COMSEC key (TEK) to provide cipher text capability. TEK can be loaded into the RCU from an ANCD using the standard ICOM fill procedure by selecting "RCU" rather than ICOM from the appropriate ANCD menu.

**FH DATA**

The RCU does not require FH data. When the net is operating in the FH mode, FH data in the RT enables frequency hopping capabilities.

**FRONT PANEL**

RCU controls are as shown in Figure 4-23, below. They differ from the RT only in the following ways:

- The RCU front panel contains a speaker connector and control (for LS-685), but has no antenna or RXMT connector.
- For the RCU FCTN control, the RT "REM" position is replaced with "ICM," (meaning intercom).

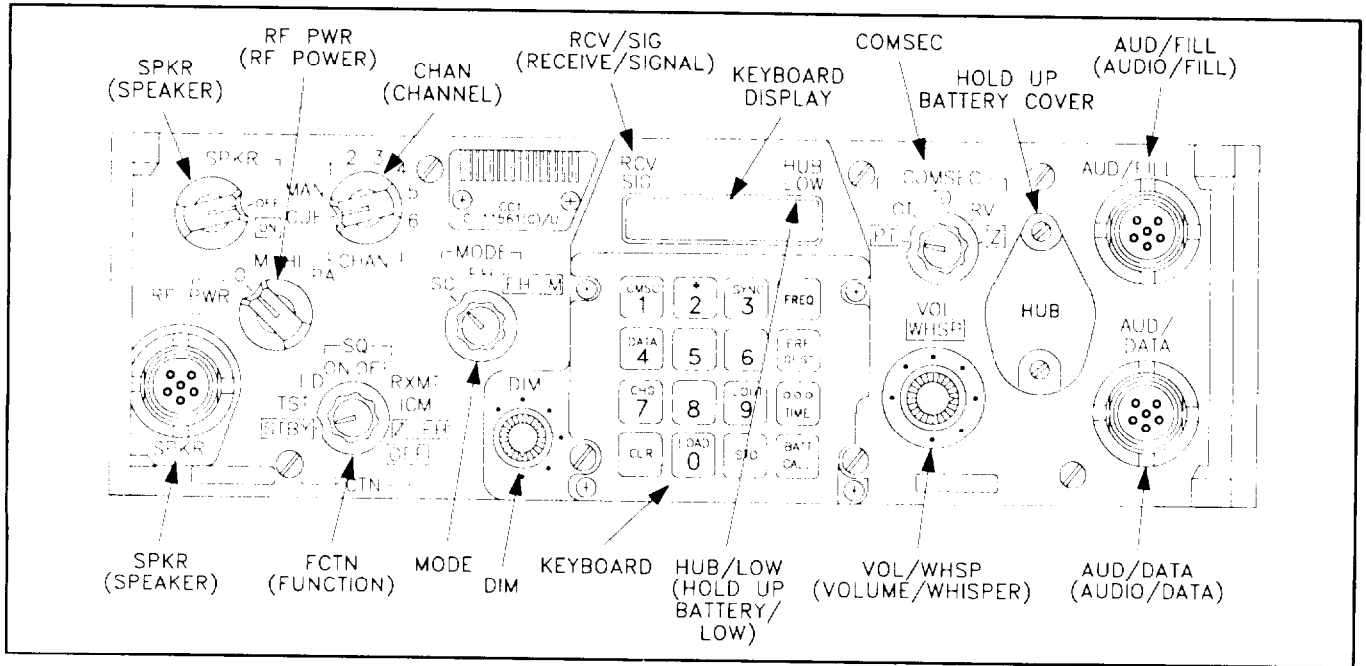

**Figure 4-23. RCU FRONT PANEL**

### CONFIGURATIONS

The RCU may be used in conjunction with a SINCGARS radio in any of the following configurations:

- Dismounted RCU to a manpack radio. (See Figure 4-24, below)

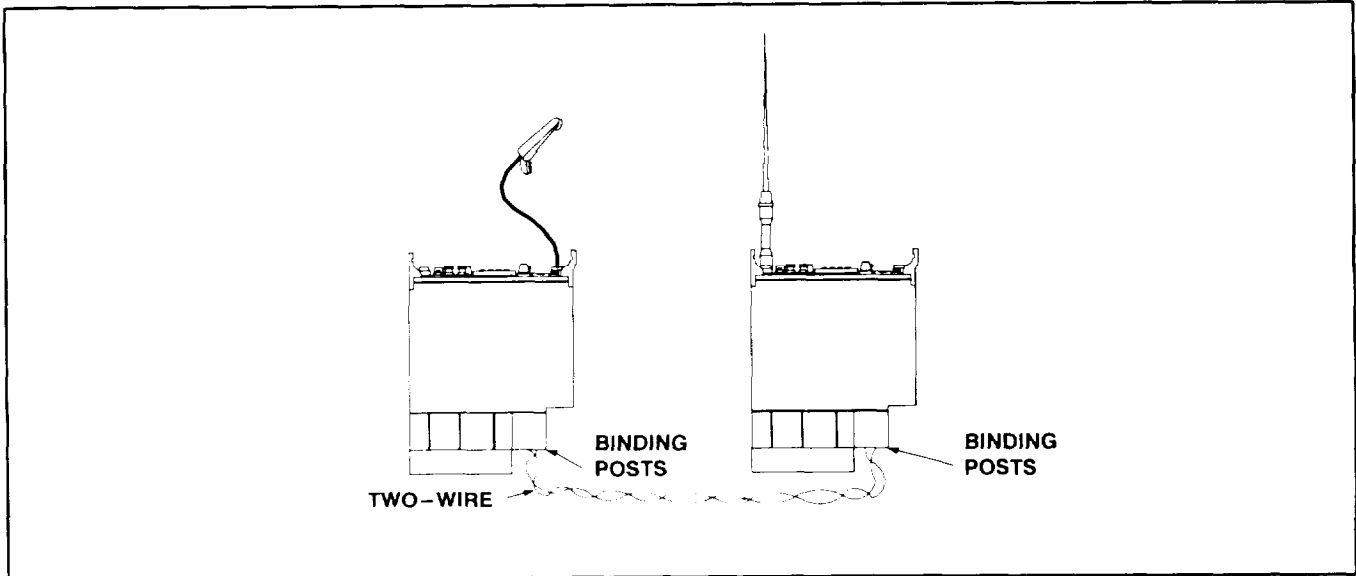

Figure 4-24. DISMOUNTED RCU TO MANPACK RADIO

- Dismounted RCU to a vehicular radio. (See Figure 4-25, below)

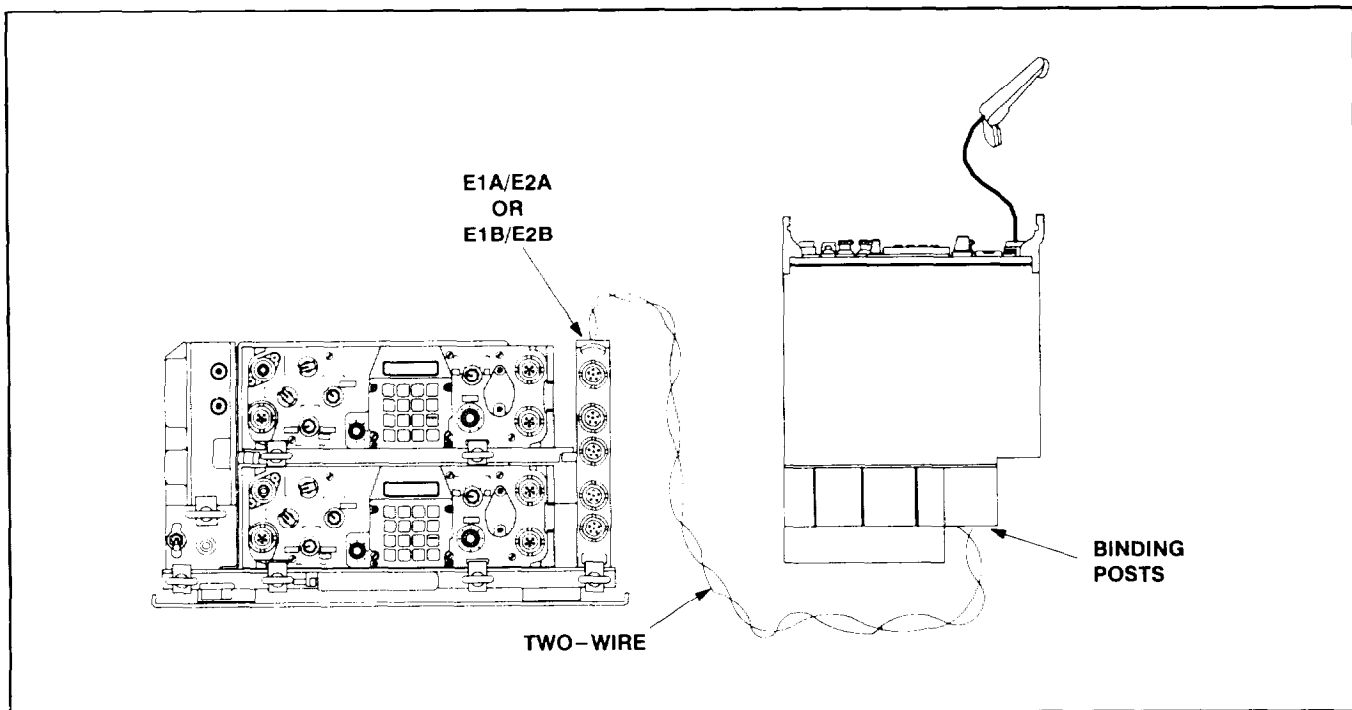

Figure 4-25. DISMOUNTED RCU TO VEHICULAR RADIO



- Vehicular mounted RCU (located in VAA) to a manpack radio. (See Figure 4-26, below)

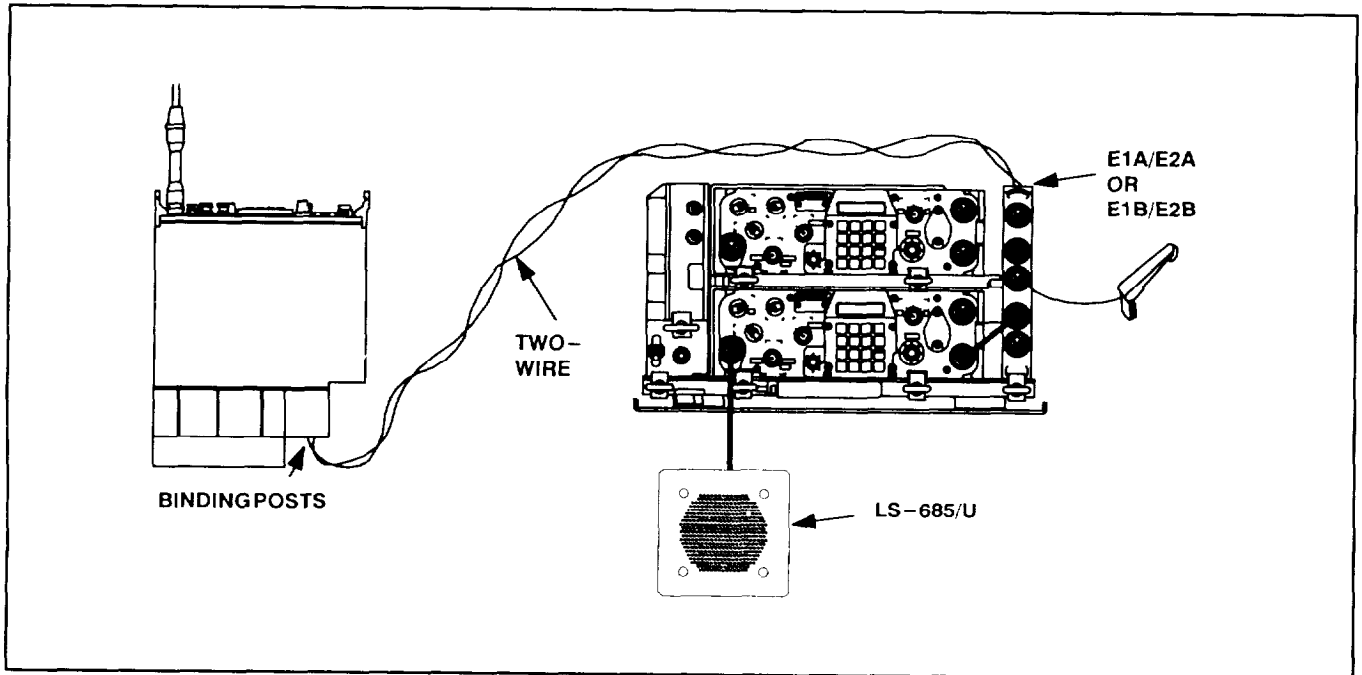

Figure 4-26. VEHICULAR MOUNTED RCU TO MANPACK RADIO

- Vehicular mounted RCU to vehicular radio. (See Figure 4-27, below)

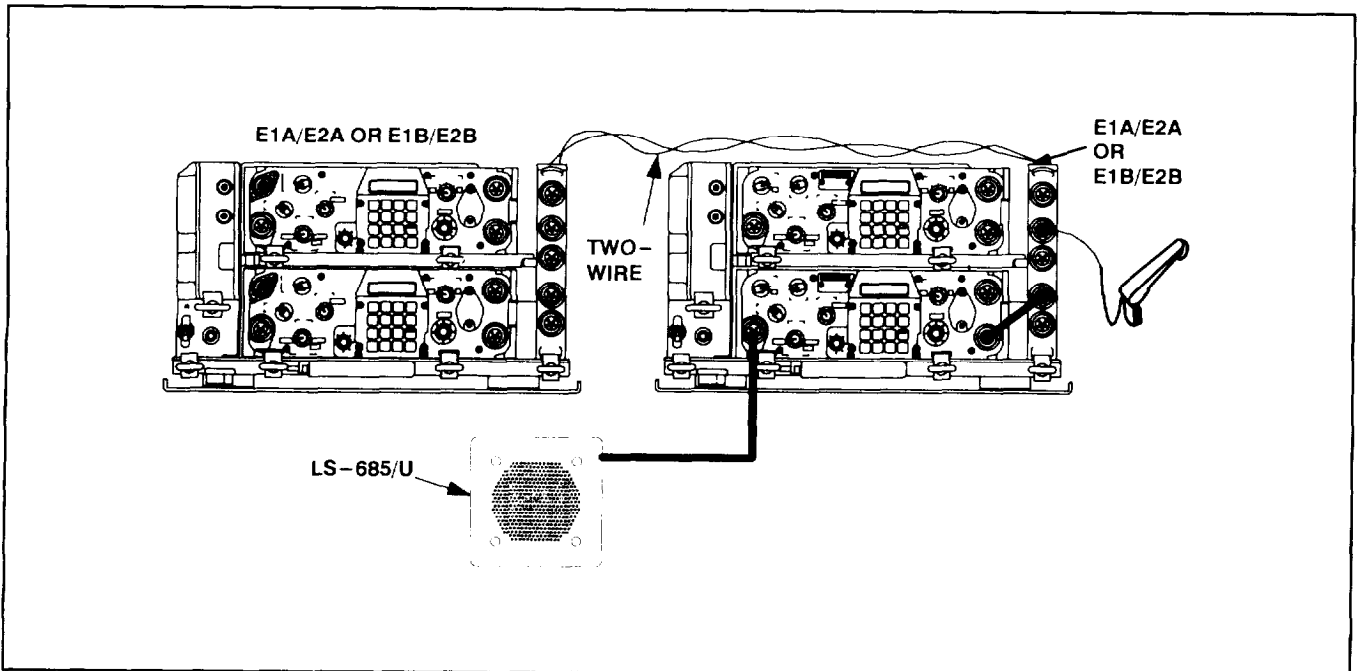

Figure 4-27. VEHICULAR MOUNTED RCU TO VEHICULAR RADIO

## OPERATION

Only those functions which differ from the radio are described below:

- Speaker Switch: turns loudspeaker ON and OFF (volume is controlled by the RCU VOL control, which deactivates the loudspeaker when set to WHSP mode).
- FCTN TST position: provides self-test of both RCU and radio.
- FCTN ICM position: allows RCU and radio operators to talk over connecting field wire when COMSEC is set to PT.
- CHAN switch: enables RCU operator to select channel 1-6, CUE, or MAN for the companion radio.
- SIG display: lights at RCU when radio receives signal. (For RT- 1523C/E, "RCU" is displayed when the radio receives a signal.)
- HUB indicator: shows status of RCU HUB only (radio HUB must be checked by radio operator).
- BATT button: checks status of RCU manpack battery when pressed once; checks manpack radio battery status when pressed a second time.
- CALL button: enables RCU operator to create a tone and "CALL" message at companion radio by setting FCTN to ICM and pressing CALL and PTT at the same time. With radio FCTN set to REM, the radio operator can call the RCU operator by merely pressing the CALL button and PTT at the same time.

## REMOTE FUNCTIONS

The following functions can be performed by the RCU operator located up to 4 KM away from the radio:

- Single channel frequencies may be loaded and offset.
- ERFs may be sent and received.
- Radio MODE may be changed (SC, FH, FH-M).
- Radio FCTN may be changed (radio will transmit and receive only in the REM position).
- Radio channels may be changed.
- COMSEC positions of PT and CT may be selected.
- COMSEC keys may be selected by scrolling.
- Radio data rates may be selected.

**OPERATING RULES**

The following rules apply to the operation of the RCU in conjunction with a SINCGARS radio. They are made necessary by the manner in which the two components work together. It is important that they be followed to preclude operational problems.

- Ensure the RCU is turned ON before setting the radio FCTN to REM (otherwise data will be lost in the radio).
- COMSEC keys in the radio cannot be cleared from the RCU, only at the radio.
- The RCU display will show "OPEN" whenever the connecting field wire is disconnected or cut, or when the companion radio FCTN is set to other than REM. If the connecting field wire is disconnected or cut, the radio automatically changes FCTN to STBY.
- When the RCU FCTN is set to STBY, the radio FCTN will change to that position after about 15 seconds.
- Radio battery life condition cannot be set from the RCU, only at the radio.
- ICOM fill of the radio cannot be done remotely, only at the radio.
- If vehicular radio uses a Control Monitor, it must be disconnected before the RCU can be employed.
- The normal operating position of RCU FCTN switch is SQ ON.
- A "FAIL 9" message resulting from self-testing the RCU normally indicates that the test was run in PT; change COMSEC to CT and re-run the test. If "FAIL 9" appears after running test in CT see unit maintenance.

**4.11b. Use of RT as RCU**

**DESCRIPTION**

The SIP/ASIP RT can be used as a Remote Control Unit (RCU), replacing the C-11561 RCU. When used as an RCU, the SIP/ASIP RT accommodates both Enhanced and SINCGARS Data Modes. If the C-11561 RCU is used with the SIP radio, only the SINCGARS Data Modes (SDM) may be used. Otherwise, operation of the SIP RT when used as an RCU is identical to procedures used with RCU C-11561.

**REMOTED RADIO**

The FCTN switch of the remoted radio is set to "REM," which disables the front panel of that RT because control is exercised from the RCU(RT). The remoted radio defaults to CT when placed in "REM" mode.

**RCU(RT) SELECTION**

The FCTN of the RCU(RT) is set to SQ ON. The "RCU" feature of the SIP/ASIP radio is selected by pressing [RCU] on the RT keypad and then pressing [CHG] until "RCU" appears in the display.

**ORDERWIRE**

By placing the RCU(RT) FCTN switch in the REM position, the RCU(RT) operator can talk with the remoted radio operator over the non-secure two-wire connection. This two-wire connection is also called an "orderwire."

**COMSEC**

As with the C-11561 RCU, orderwire voice communications over the two-wire connection between RCU and remoted RT are plain text, not encrypted.

**APPLICATION**

The SIP/ASIP RT can be used as an RCU in all data modes, SINCGARS (SDM) and Enhanced (EDM).

**4.11c. Use of LS-671****SOURCE**

Loudspeaker, LS-671, is a part of selected installation kits. (See SB 11-131-2 for a listing of individual kits.)

**PURPOSE**

The primary purpose of the LS-671 is to allow for remote transmitting and receiving of voice communications to the length of the LS-671 cable (CX-13292) being used. Cables are available in lengths varying from 3 to 100 feet.

**FUNCTIONS**

At the LS-671, these functions can be performed (see Figure 4-28, below for controls available):

- Radio can be turned ON and OFF by use of the power switch.
- By connecting a handset to the LS-671 (J2), the radio can be keyed and messages transmitted.
- Net traffic can be monitored by proper adjustment of the loudspeaker volume control.

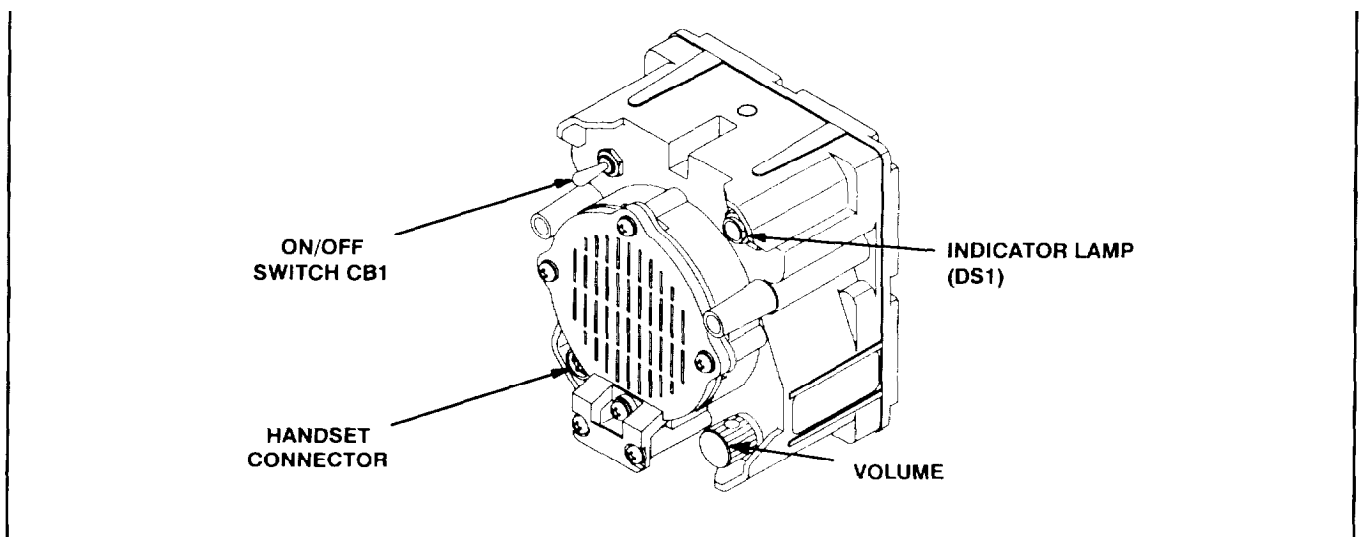

**Figure 4-28. Loudspeaker, LS-671**

**LIMITATIONS**

The remote capabilities of the LS-671 complement rather than replace those of the RCU. Where the RCU supports remote operation up to 4 KM, the LS-671 is limited to 100 feet at most. Also, the LS-671 provides for only the most basic radio control functions.

**ADVANTAGES**

The LS-671 is extremely useful for command posts and fire control centers where operations personnel are performing other than radio operator functions. The limited remote capability of the LS-671 enables such personnel to operate the radio from their work station with minimum effort or movement. Only occasionally is it necessary for a crewmember to move to the radio front panel to make control setting changes.

**4.11d. Use of Control-Monitor**

**SOURCE**

The Control-Monitor (C-M) (C-11291) is a part of selected installation kits. (See DA Pam 25-30 for listings of individual kits.)

**PURPOSE**

The purpose of the control monitor is to enable vehicle crews to operate their radios from positions other than directly at the radios.

**FUNCTIONS**

One control monitor can provide for control of up to three radios, one at a time. Most functions of the radio are included. Filling the radio with COMSEC, FH data, and sync time are exceptions.

**CONTROLS**

See Figure 4-29, below, for a view of C-M controls. The function each major control performs is described below.

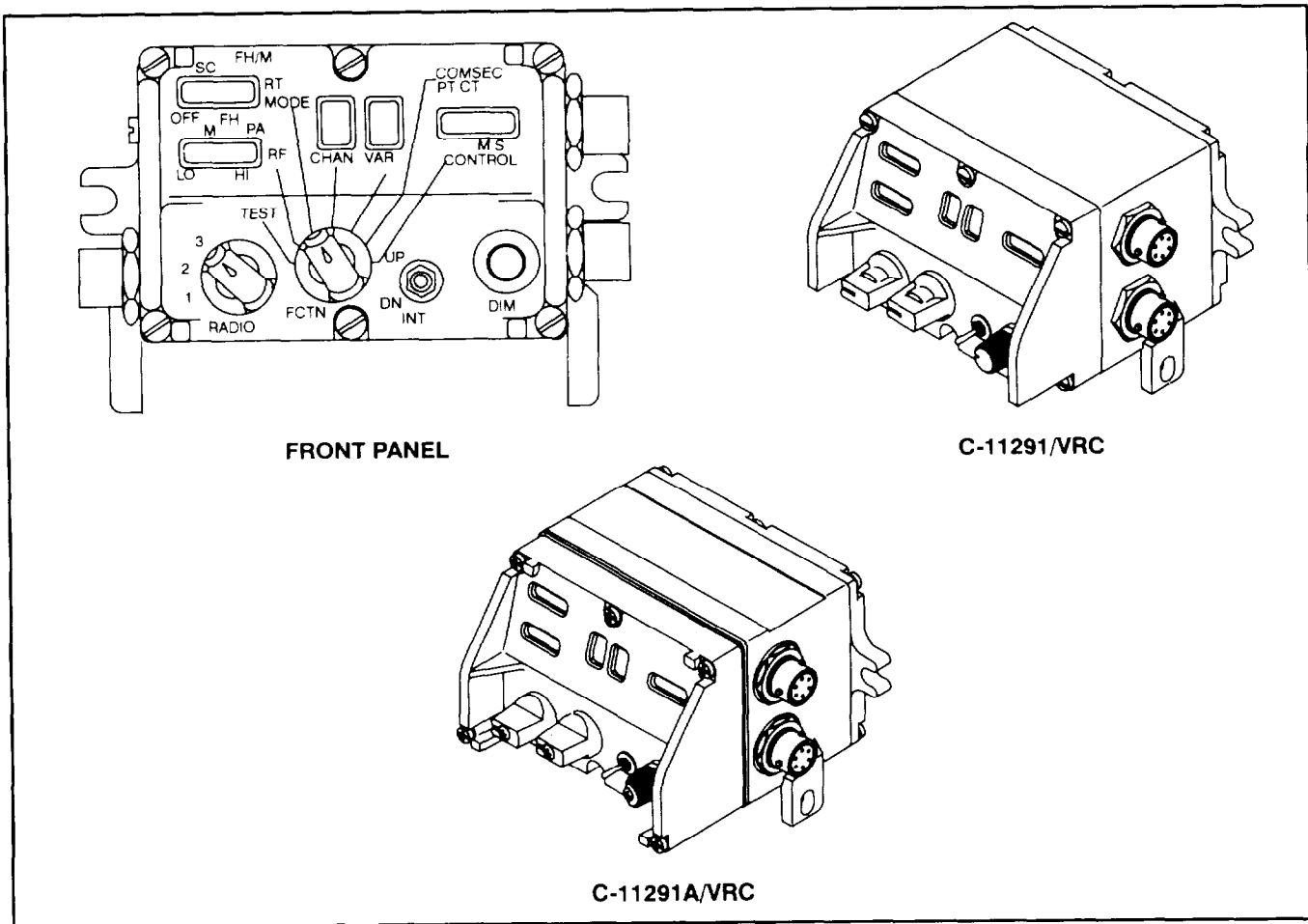

Figure 4-29. CONTROL-MONITOR

- FCTN Switch: Run self-test (TEST).
- FCTN Switch (Used with the INIT switch to):
  - Set RF Power (RF).
  - Set AT MODE (RT MODE), to include turning power off.
  - Change channels (CHAN).
  - Select COMSEC key (VAR).
  - Select CT or PT (COMSEC).
  - Control status (Should read "M").
- INIT Switch: Used in conjunction with the FCTN switch to make the changes cited above. Moving the INIT UP causes FCTN markers to move to the right; moving it DOWN moves markers to the left.
- RADIO Switch: Selects the radio to be controlled.
  - Position 1 controls the RT in the A position of the VAA;
  - Position 2 controls the RT in the B position of the VAA, and,
  - Position 3 is for an RT in the A position of a second VAA.

**OPERATING PROCEDURE**

To place the control monitor in operation and be assured it is performing properly, follow the steps shown in Figure 4-30, below.

(1)	Set VAA CB1 to ON; VIC (if used) to ON; RT FCTN to REM.
(2)	Test C-M: set C-M FCTN to TEST; check displays; must read "Gd" and "M" or "S" at end of test.
(3)	Set RADIO switch to RT being controlled; CONTROL must indicate "M" (if not set FCTN to CONTROL and use INIT switch to change).
(4)	Check initial displays: RF at LO; RT MODE at SC; CHAN at 0; COMSEC at PT; VAR blank (If display shows "F7" lift INIT and release; "Ud" (update) should then appear and controls show as above).

**Figure 4-30. CONTROL MONITOR OPERATION**

**4.11e. Use of Wire Line Adapter, HYX-57**

**COMSEC**

The Wire Line Adapter, HYX-57, when used in conjunction with a KY-57, provides secure radio remote operation capability.

**COMPONENTS**

The Wire Line Adapter consists of local and remote units, which are connected by field wire for operation.

**CABLING**

Figure 4-31, below, shows the set up for remote operation of a SINGARS radio using an HYX-57 and KY-57

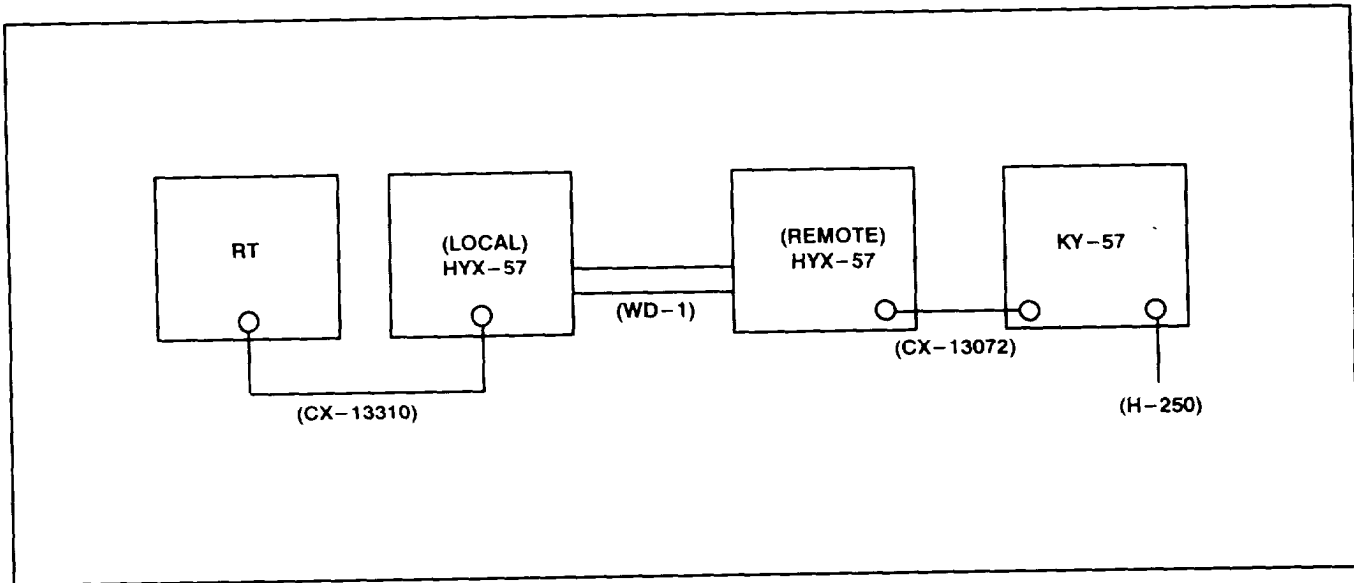

Figure 4-31. Wire Line Adapter Set Up



**4.11f. Use of Remote Control Device (C-2329/GRA-39)**

**COMSEC**

The Remote Control Device, C-2329/GRA-39, also provides for remote operation of SINCGARS radios, but the wire line connection is not secure.

**SET UP**

Figure 4-32, below, shows a typical set up using local and remote control units, terminating as illustrated in a TACFIRE device. Various devices can be used, including a handset.

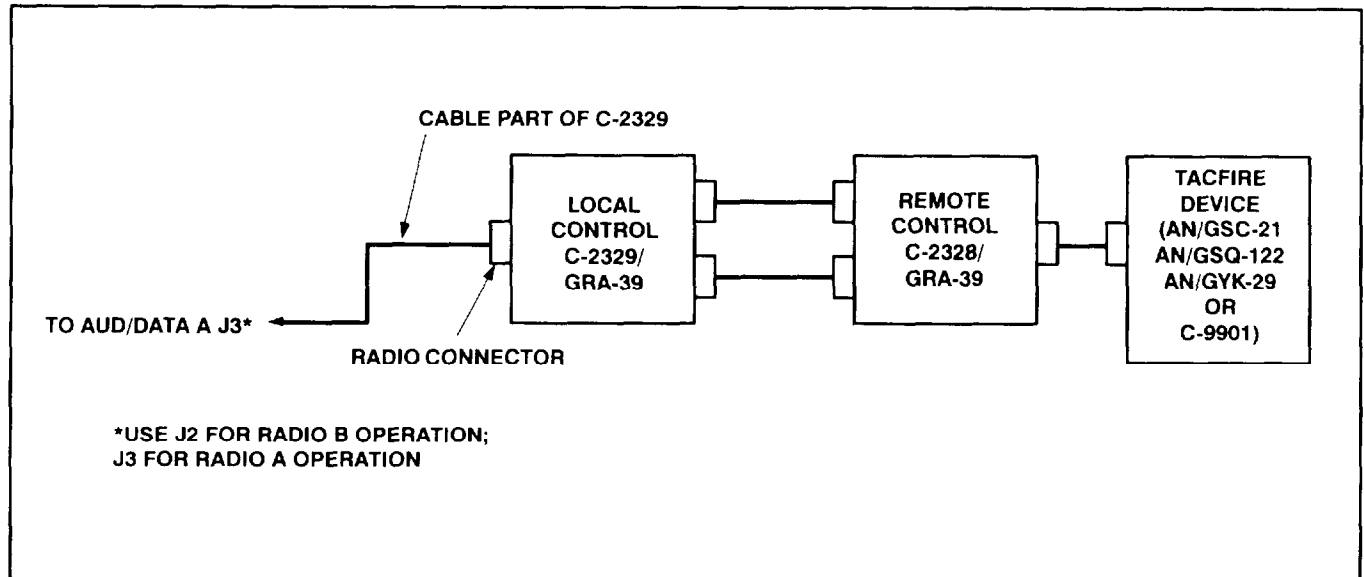

Figure 4-32. GRA-39 SET UP

## 4.12. NET MANAGEMENT

### 4.12a. Net Discipline

#### IMPORTANCE

Net discipline is important for all combat net radios, but it is especially so for SINCGARS. For the members of the net to communicate, each radio must have the same COMSEC key, FH data, and sync time. While the NCS radio, set to the FH - M position, automatically maintains sync time in all net radios within the required +/- 4 second window, use of the FH-M position by other than the NCS can cause the net to lose common sync time and divide into two or more nets unable to communicate among them.

#### UPDATES

COMSEC keys, TSKs, and SOI information must be replaced at prescribed intervals. Changeover from one set of data to another demands net discipline. Changeover must take place at the time prescribed, and the new data being introduced must be the correct data for that time.

#### SYNC TIME

Net discipline is especially critical to the maintenance of exact sync time. Nets are opened using precise GPS time, and NCS transmissions pull the operating sync time of net member radios to that of the NCS radio. Also, the SINCGARS radio offers the operator the means for reading the sync time in the radio. The ANCD and PLGR offer the means for reloading sync time into the radio. But when SINCGARS operators misuse their TIME control, they can be effectively taken out of the FH net. An important aspect of operator net discipline is to leave the TIME control alone unless there is a specific need to make a change.

#### LOADING CUE FREQ

Most net operators require a CUE frequency only when they need to perform a CUE and ERF method of late net entry. If a CUE frequency is loaded routinely, that operator will see a "CUE" message in the radio display every time any station sends a CUE signal. Only the NCS and alternate NCSs should routinely load a CUE frequency. Net operators can obtain the required CUE frequency from their ANCD when one is needed.

**4.12b. Role of the NCS**

It is the NCS who is responsible for SINCGARS net discipline. NCS responsibilities include:

<b>DATA</b>	Ensuring all net members have the correct COMSEC key, FH data, and sync time for net operations.
<b>NET OPENING</b>	Opening the net at the prescribed time to support unit mission requirements,
<b>NET STATUS</b>	Knowing which net operators have and have not entered the net.
<b>SYNC TIME</b>	Transmitting (or at least pressing PTT) often enough to ensure that net sync time is maintained.
<b>CUE CALLS</b>	Ensuring that CUE calls are answered
<b>ACCESS CONTROL</b>	Controlling access to the net
<b>USE OF RXMT</b>	Employing RXMT capabilities when required.
<b>HELP</b>	Verbally assisting operators having trouble with task performance.
<b>ADMIN TRAFFIC</b>	Ensuring that administrative communications requirements do not interfere with unit mission control communications.
<b>ALT NCS</b>	Making full use of alternate NCS operators to preclude distraction from primary NCS requirements.

**4.12c. Role of the Alternate NCS**

<b>NET OPENING</b>	While the NCS sets the time of opening and logs stations into the net, it is the Alternate NCS who follows up and brings all late entry operators into the net.
<b>UPDATES</b>	When net data is updated, whether electronically or by physical distribution, it is the Alternate NCS who maintains a radio on old data and ensures that all net operators make the transition successfully.
<b>CUE CALLS</b>	It is the Alternate NCS who responds to all CUE calls, leaving the primary NCS free to control the net.
<b>DISPLACEMENT</b>	Also, it is the Alternate NCS who physically changes positions shortly following each use of SC communications to prevent enemy location by direction finding.
<b>NUMBER</b>	There is no limit, other than operational, on the number of Alternate NCSs that may be employed. The important point is that the use of Alternate NCSs is essential if the NCS is to meet all primary net responsibilities.

#### 4.12d. Special Task Performance

##### OPERATOR

There are nine Special Operator Tasks, described in detail in Chapter 5. Most net operators do not need to be able to perform these tasks. Some operators will be required to perform only certain special tasks, for example, retransmission operations. Those operators who do need to perform one or more special tasks must be given extra training on an as required, mission basis.

##### NCS & ALT NCS

There are five Special NCS Tasks, described in detail in Chapter 6. These tasks involve the electronic transfer of COMSEC keys, FH data, and SOI information from NCS to NCS, and from NCS to net operators. Whether or not all NCS and Alternate NCS personnel need to be able to perform any or all of these special tasks is a matter of command policy based upon mission requirements. If an NCS or Alternate is expected to perform any of these tasks, special training must be provided.

#### 4.12e. Operator Proficiency

##### PRIMARY TASKS

There are five primary tasks that all unit SINCGARS operators must be able to perform without assistance during unit mission operations. They are described in detail in Chapter 5.

##### POCKET GUIDE

Each operator is provided a copy of TM 11-5820-890-10-6, "SINCGARS Ground Operator's Pocket Guide." By carrying this guide with them on the job and by following the procedures provided, operators can be assured of required job task proficiency.

##### OPTIONS

When overall operator proficiency is low due to personnel turnover or other factors, units may elect to have communications specialists or designated NCOs perform selected tasks such as loading data and sync time into radios.

##### COMM-EX

Whether the objective is to build or maintain SINCGARS operator proficiency, there is no better or easier tool to use than the unit communications exercise. Opening nets frequently and having operators transmit and receive realistic traffic are important requirements. Weekly, short duration COMM-EXs, are one of the best ways to conduct SINCGARS sustainment training for both operators and NCS personnel. Unit sustainment training is the key to SINCGARS proficiency.

#### 4.12f. MSE Compatibility

##### DESIGN

SINCGARS and the Mobile Subscriber Equipment (MSE) System were designed to work together on the battlefield. The two systems even share some frequencies without interference to either.

##### CO-LOCATION

Some vehicles, such as command post vehicles, have both SINCGARS and MSE radios installed. The Mobile Subscriber Radio Telephone (MSRT) and a SINCGARS radio cannot be operated from the same vehicle at the same time unless one or both of the antennas are removed.

**4.129. Role of Signal Officers/NCOs****IMPORTANCE**

The important role of unit Signal Officers and Non-Commissioned Officers has been significantly increased with the fielding of the SINCGARS system.

**FUNCTIONS**

Some of the SINCGARS-related specific functions performed by Signal Officers and NCOs are:

- Development and distribution of loadsets, including those required to support task organization changes.
- Distribution of new data in timely manner and maintenance of data reserves.
- Advising and assisting NCS personnel and unit operators as required.
- Ensuring operator and NCS job proficiency; to include conducting training if required.
- Developing and implementing unit sustainment training programs, including periodic COMM-EXs.
- Advising commander on COMSEC requirements, including compromise recovery procedures.
- Advising and assisting commanders and SINCGARS users in equipment and system interfaces to include: AFATDS, ASAS, CSSCS, FAADC2, IFSAS, IVIS, MCS, MSE, and TACFIRE/LIGHT TACFIRE, as required. (See appropriate technical bulletin, TB 11-5820-890-10 series.)

THIS PAGE INTENTIONALLY  
BLANK.

## CHAPTER 5

### O P E R A T O R T A S K S

#### IN THIS CHAPTER:

<b>5.1</b>	<b>GENERAL</b> .....	<b>5-2</b>
<b>5.2</b>	<b>START-UP PROCEDURE</b> .....	<b>5-3</b>
<b>5.3</b>	<b>OPERATOR CONTROLS</b> .....	<b>5-5</b>
	a. SINCGARS Receiver-Transmitter (RT) Controls .....	5-5
	b. Technical .....	5-13
	c. Remote Control Unit (RCU) Controls .....	5-18
	d. Automated Net Control Device (ANCD) Controls .....	5-19
	Precision Lightweight GPS Receiver (PLGR) Controls .....	5-21
	f. Control-Monitor (C-M) .....	5-22
	g. Loudspeaker (LS-671) .....	5-24
	h. Vehicular Intercommunications Set (VIC) .....	5-25
<b>5.4</b>	<b>PRIMARY OPERATOR/PREPARATION TASKS</b> .....	<b>5-28</b>
	a. Definition of Primary Operator/Preparation Tasks .....	5-28
	b. Summary of Primary Operator/Preparation Tasks .....	5-28
	c. Select RT Preparation Settings from MENU (Preparation TASK 1) ...	5-29
	d. Load Single Channel Frequencies into RT (Primary Operator Task 1) .....	5-30
	e. Load COMSEC/FH Data/Sync Time into RT Using ICOM Fill (Primary Operator Task 2) .....	5-32
	f. Perform Hot Start Net Opening (Primary Operator Task 3) .....	5-34
	g. Perform Passive Late Net Entry (Primary Operator Task 4) .....	5-36
	h. Obtain SOI Information from ANCD (Primary Operator Task 4) .....	5-37
<b>5.5</b>	<b>SPECIAL OPERATOR TASKS</b> .....	<b>5-42</b>
	a. Definition of Special Operator Tasks .....	5-42
	b. Summary of Special Operator Tasks .....	5-43
	c. Transfer COMSEC/FH Data from ANCD to ANCD (Special Operator Task 1) .....	5-45
	d. Transfer QREF SOI Information from ANCD to ANCD (Special Operator Task 2) .....	5-47
	e. Transfer Full SOI Information from ANCD to ANCD (Special Operator Task 2 Alt) .....	5-49
	f. Perform Cold Start Net Opening (Special Operator Task 3) .....	5-51
	g. Receive Net Update ERF from NCS (Special Operator Task 4) .....	5-53
	h. Perform CUE and ERF Late Net Entry (Special Operator Task 5) ....	5-55
	i. Conduct Retransmission Operations (Special Operator Task 6) ....	5-56
	j. Send ERF as Part of RXMT Operation (Special Operator Task 7) ....	5-58
	k. Change Net ID (Special Operator Task 8) .....	5-60
<b>5.6</b>	<b>SPECIAL OPERATOR TASKS (SIP/ASIP)</b> .....	<b>5-62</b>
	a. Use SIP/ASIP RT as an RCU (Special Operator Task 9) .....	5-62
	b. Send Data Via RS-232 Mode (Special Operator Task 10) .....	5-63

<b>5.7</b>	<b>OTHER OPERATOR PROCEDURES .....</b>	<b>5-64</b>
	a. Battery Life Condition Indicator .....	5-64
	b. Loading and clearing Offset Frequencies .....	5-67
	c. Scrolling COMSEC Keys .....	5-67
	d. Scanning Capability .....	5-68
	e. Jamming and Anti-Jamming Actions .....	5-69

**15.1. GENERAL 1**

**BY DESIGN**

The SINCGARS radio was designed for ease of operation by the non-technical (“general purpose user”) operator. Once the radio has been put into operation and the operator has entered the net, there are but few requirements left for the operator to perform. Technically, the SINCGARS radio is as complex as it is capable. Operationally, it is simple and easy for the operator to use.

**TASK DIVISION**

The SINCGARS radio offers many more capabilities than are routinely employed. Retransmission (RXMT), for example, is a built-in SINCGARS capability, which is of great value when needed. When it is needed, not every operator in the unit will be involved. Only a select few operators need to be trained on this task. It is on this basis that operator tasks have been divided into “Primary” and “Special,” as discussed below.

**TRAINING MATERIALS**

The job of the SINCGARS operator has also been simplified by the statement of task procedures in clear, easy to follow, steps. Also, the operator is provided a small pocket guide containing abbreviated task procedures covering all operator requirements. This pocket guide serves as a memory jogger for the trained operator, precluding any need to memorize any aspect of SINCGARS radio operation.



**5.2. OPERATOR START-UP PROCEDURE****DRAW EQUIPMENT**

In a typical peacetime situation, the operator will obtain required communications gear from a communications or supply facility. Manpack operator's equipment will include a main power battery in addition to all radio components. Vehicular radio operator's equipment may include a "dismount" radio (including main power battery) in addition to all of the vehicular radio components.

**ANCD**

Depending upon unit policy, selected operators will probably draw ANCDs already loaded with proper COMSEC keys, FH data, and sync time for current unit operations. When unit SOP calls for centralized control of ANCDs, the operator is advised when and where to obtain ANCD support.

**ASSEMBLY**

Operators are expected to properly assemble manpack radios and install required vehicular radio components in preparation for net opening. This includes connecting cables, antennas, handsets, loudspeakers, and any other components that are to be used.

**CAUTION****YOUR RT CAN BE DAMAGED BY****IMPROPER ATTACHMENT OF MANPACK ANTENNAS**

1. To avoid damage, turn the sleeve only, not the antenna.
2. Turning the antenna can destroy the antenna connector in the RT.

**PMCS**

After completing radio assembly, operators perform their Before Operation Preventive Maintenance Checks and Services (PMCS), as shown in Chapter 8. Performing PMCS involves checks of controls, cables, antennas, power source, self-test, keypad, data loading, and ability to communicate. By performing PMCS the operator is assured that all components of the radio are working properly, or that something needs to be fixed, by the operator or unit maintenance. The PMCS charts found in Chapter 8 should be followed exactly in the performance of PMCS. No operator action will pay greater dividends.

**STATUS**

Upon completion of Before Operation PMCS actions, the operator is ready to load the radio with data and enter the net. The first three of the five Primary Operator Tasks provide detailed procedures for doing just that.

**5.3. OPERATOR CONTROLS**

**5.3a. SINGARS Receiver-Transmitter (RT) Controls**

**GENERAL**

The SINGARS radio has seven controls, plus the RT keypad and display, for the operator to use. Several of these controls are used infrequently, but they are available when required. Each control is described below. See RT front panel graphic for the location of each.\*

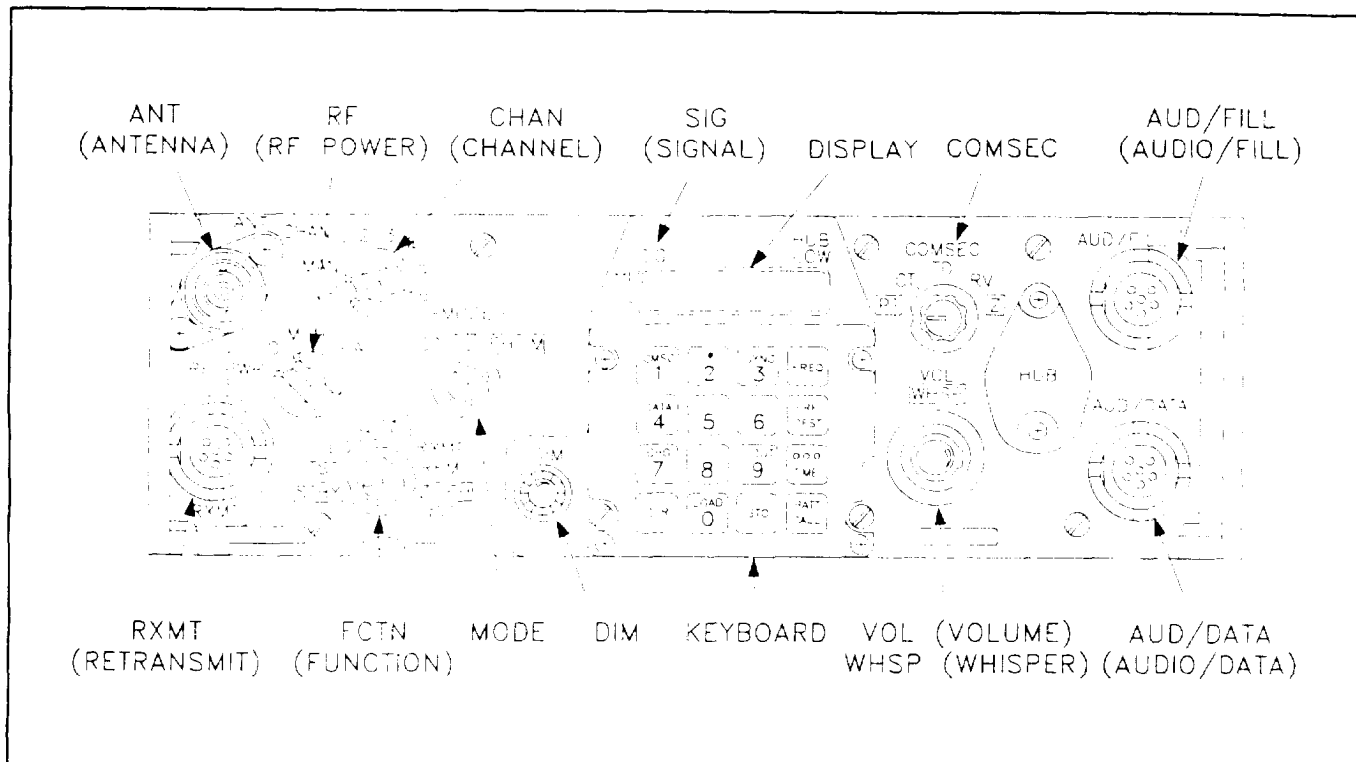
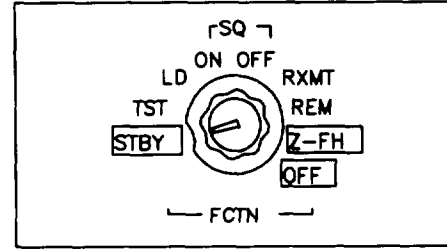

**Figure 5-1. SINGARS RT FRONT PANEL**

\* Some control positions found on the RT front panel are enclosed in a box. To move the control into or out of these positions, the operator must **pull out** on the control knob. These controls are spring loaded and will return to normal position when released.

**FCTN (FUNCTION)**

This is the primary control with which the operator determines what function the radio is to perform. The FCTN switch has nine positions, as described below.



**Figure 5-2. FCTN (Function) Switch**

**FCTN CONTROL POSITIONS AND USES**

POSITION	PURPOSE
<b>OFF</b>	All power IS shut off; all stored data, (COMSEC, FH. sync time, and manpack battery life indicator) are deleted after 5 seconds; radio is completely inoperative; position is used when radio is not is use and for storage.
<b>Z-FH</b> (Zero-FHdata)	Clears all FH data after 5 seconds: operator pauses in this postion for 5 seconds when setting FCTN switch to OFF.
<b>STBY</b> (Stand By)	Makes radio Inoperative but all stored data is retained; sync time is lost after 24 hours; setting FCTN to SQ ON returns radio to fully operational status. In STBY, power IS drawn from main source. (RT-1523B/C/D/E standby time has been Increased to 200 hours.)
<b>TST</b> (Test)	This position causes RT to perform self-test of RT, data, and ECCM circuits; test results are shown in RT display. Running RT self-test IS a routine step in start up procedure.
<b>LD</b> (Load)	The load position is required for loading SC frequencies, FH data, and COMSEC keys; required also to receive an ERF.
<b>SQ ON</b> (Squelch On)	This is the normal operating position of the radio for FH mode. For SC mode, this position reduces noise.
<b>SQ OFF</b> (Squelch Off)	This position IS not used for the FH mode. In the SC mode, SQ OFF helps to bring in distant stations, to work through jamming, and to be compatible with radios lacking squelch capability.
<b>REM</b> (Remote)	The REM position disables front panel controls and is required for use of the Control-Monitor and Remote Control Unit (RCU).
<b>RXMT</b> (Retransmit)	Use of the RXMT position enables the RT to automatically retransmit traffic from one radio through another. Both RTs are set to RXMT position and connected by an RXMT cable.

**MODE SWITCH**

The MODE switch contains three positions for selecting SC or FH mode of operation. It also provides an FH-M position that controls net sync time and is for use by NCS personnel only.

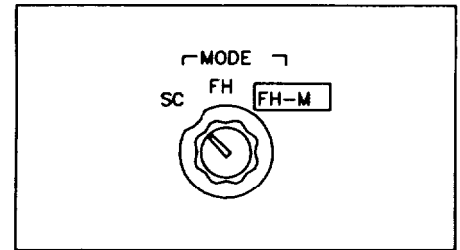

Figure 5-3. MODE Switch

**MODE SWITCH POSITIONS AND USES**

POSITION	PURPOSE
<b>SC</b> (Single Channel)	Selection of the SC position places the radio in the single channel mode of operation.
<b>FH</b> (Frequency Hopping)	Selection of the FH position places the radio in the frequency hopping mode of operation.
<b>FH-M*</b> (Frequency Hopping-Master)	The FH-M position, used by NCS operators only, causes the NCS radio to electronically keep all net radios within the plus or minus 4 second window required for frequency hopping communications.

**CHAN (CHANNEL)**

This control allows the operator to select from among eight SC and six FH channels. These preset channels are tuned electronically for ease of operation. Net change is accomplished by merely moving the switch from one channel to another.

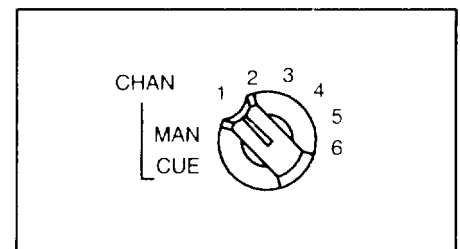

Figure 5-4. CHANNEL Switch

**CHANNEL SWITCH POSITIONS AND USES**

POSITION	PURPOSE
<b>1,2,3,4,5,6</b>	Channel switch positions 1 through 6 are used for SC and/or FH nets. These channels are routinely loaded with COMSEC keys, FH data, and sync time as required for unit communications.
<b>CUE</b>	With the correct SC frequency loaded in this position, an operator with a non-FH radio is able to contact a frequency hopping net. This position may be used for another SC net if desired.
<b>MAN</b> (Manual)	The Manual position is required for sending and receiving the Cold Start net opening ERF. This position also may be used for another SC net.

**RF PWR (RF POWER)**

This control allows the operator to adjust the level of radio frequency (RF) power and related range of operation. Basic rule is to use the least amount of RF power needed to communicate with other stations.

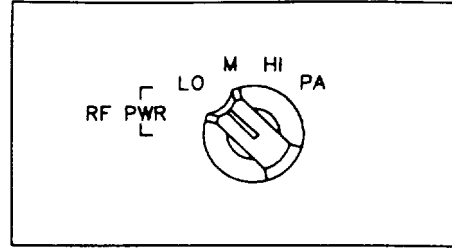

Figure 5-5. RF PWR Switch

**RF POWER SWITCH POSITIONS AND USES**

POSITION	PURPOSE
<b>LO</b> (Low Power)	Provides voice operational range of approximately 200-400 meters. This position is used extensively by units in closely deployed situations. Actual range is dependent upon weather, position, line of sight, Interference, and various other factors.
<b>M</b> (Medium Power)	Provides voice operational range of approximately 400 meters to 5 kilometers. Manpack radio operators can conserve battery life by selecting lowest effective RF power setting.
<b>HI</b> (High Power)	Provides voice operational range of approximately 5 to 10 kilometers and data transmission range of 1 to 5 kilometers, the latter depending upon data rate (BPS) as well as the other factors cited under LO above.
<b>PA</b> (Power Amplifier)	This setting applies only to vehicular long range radios using a power amplifier. Approximate voice range provided is 10 to 40 kilometers; data range of about 5 to 25 kilometers, dependent upon the data rate being used and various other factors.

**DIM CONTROL**

This control enables the operator to adjust the level of brightness of the RT display. Turning the knob clockwise increases the level of light; turning it counterclockwise dims the display light. When using night vision goggles, DIM is to be set fully counterclockwise.

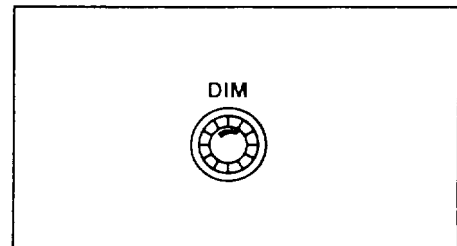

Figure 5-6. DIM Control

**VOL/WHSP**

The Volume/Whisper control enables the operator to adjust the audio level. Turning knob clockwise increases level and counterclockwise decreases it. The whisper feature is activated by pulling out on the VOL knob. In the WHSP position, the operator can speak softly (whisper) and the message will be heard at a normal audio level.

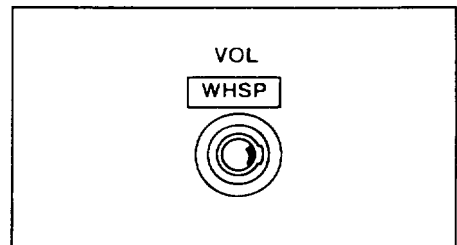

Figure 5-7. VOL/WHSP

**COMSEC SWITCH**

The COMSEC switch provides five settings for control of RT COMSEC mode. Only the CT position is normally used in field operations. Two of the positions require the operator to pull out on the knob to move into/ out of these settings.

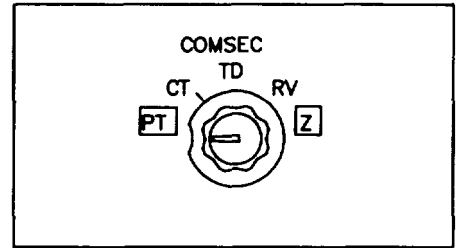

Figure 5-8. COMSEC Switch

**COMSEC SWITCH POSITIONS AND USES**

POSITION	PURPOSE
<p><b>PT</b> (Plain text)</p>	<p>This setting places the radio in plain text (not secure) mode. To prevent accidental selection of this position, the operator must pull out on the knob to enter or leave the setting. The radio must be set to the PT position when using the CUE feature.</p>
<p><b>CT</b> (Cipher Text)</p>	<p>This is the primary COMSEC setting for nets operating in the secure mode. To make use of this setting, RT must have been loaded with required COMSEC key or keys. Use of the CT function essentially prevents the enemy from intercepting your communications.</p>
<p><b>TD</b> (Time Delay)</p>	<p>This setting also provides for secure mode communications and is used when needed to compensate for transmission delays. Seek the help of a communications specialist if you think you need to use this feature of the SINGARS radio.</p>
<p><b>RV</b> (Receive Variable)</p>	<p>This setting may be used in some forms of Over-The-Air-Rekey (OTAR) transmissions, but normal operator procedures do not require its use.</p>
<p><b>z</b> (Zero)</p>	<p>This position may be used to clear the RT of stored COMSEC keys by setting the switch to Z for 5 seconds. Knob must be pulled out to enter or leave this position. When turning the radio off by moving to OFF, it is not necessary to use the COMSEC switch Z setting in order to clear COMSEC keys. (For RT- 1523E, "Z" clears all data.)</p>

**RT DISPLAY**

The RT display window located above the keypad provides the operator information regarding signal strength, status of the HUB battery and a host of operational messages such as SC frequencies, net ID numbers, sync time, and failure messages. This RT display is the primary means by which the radio communicates with its operator

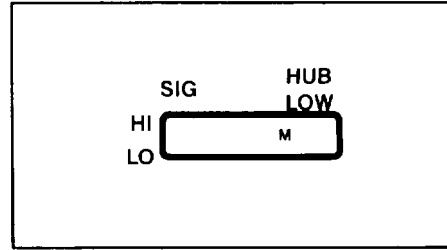

**Figure 5-9. RT Display**

**RT DISPLAY SIGNALS AND USES**

SIGNAL	PURPOSE
<p><b>SIG</b> (Signal)</p>	<p>Signal strength is shown as a lighted vertical bar at the left side of the RT display window; the higher the bar, the stronger the signal. Activation of this bar advises the operator that traffic is on the net or that an ERF or OTAR message has entered the radio. Continuous activation of the signal display bar is an indication of enemy jamming or friendly interference.</p>
<p><b>LOW HUB</b></p>	<p>When the Hold-Up Battery (HUB) becomes weak, a diamond-shaped light at the right side of the RT display will flash; if the HUB is dead or missing, this light will remain on. This light appears only while the RT display is active.</p>
<p><b>M</b> (Message)</p>	<p>Some versions of the SINCGARS radio display an "M" near the right side of the RT display indicating that traffic is being sent over the net.</p>
<p><b>INFORMATION</b> (For the operator)</p>	<p>Examples of some of the information the operator will receive from the RT are: "53550" (SC frequency); "TEK 1" (COMSEC key); "ST0_" (Store where?); "F123" (net ID); "FAIL 5" (Need to go to CT; RT- 1523 only)</p>



## RT KEYPAD

The RT keypad, also referred to as a keyboard, provides one of the primary means the operator has for entering information into the radio. It also allows the operator to obtain information from the radio.\* The function of each of the 20 keypad buttons is briefly described below. Very specific procedures and messages are found in the operator and NCS tasks, covered in Chapters 5 and 6.

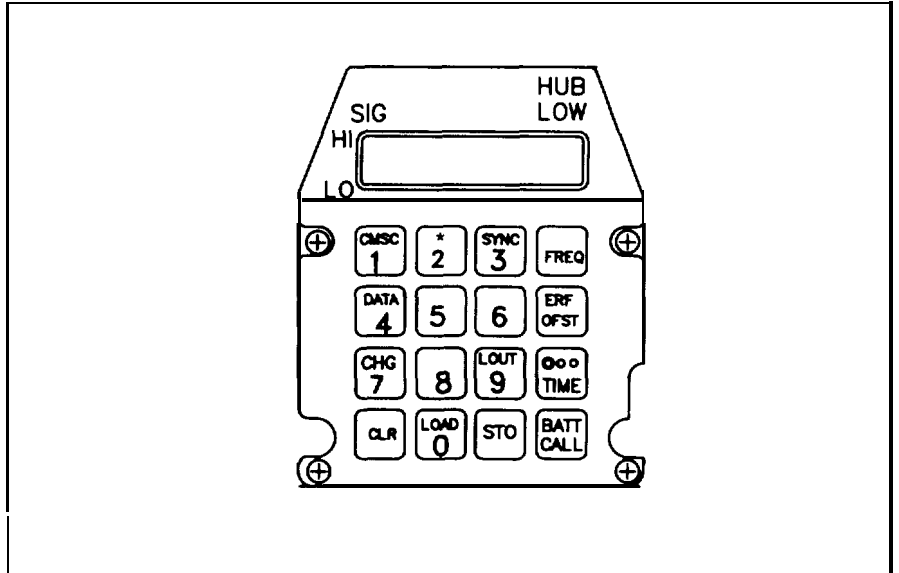

**Figure 5-10. RT KEYPAD**

When entering data into the radio through the RT keypad, keep in mind that the display will go blank about 7 seconds after your latest entry. For example, if you load 4 numbers of a SC frequency and then pause for more than 7 seconds, the display will go blank, and you will have to start over: If you need to pause during data entry, continue to hold down the last button used. The display will remain active as long as you press a key.

**RT KEYPAD BUTTONS AND USES**

KEYPAD BUTTON	PURPOSE
<b>1 THRU 0</b>	These keys enable the operator to enter numbers. Most frequent use is for entry of SC frequencies. They are also used for loading sync time via the RT keypad, and for changing net IDs.
CMSC (COMSEC)	Press this key to determine the COMSEC key position being used; RT display will show TEK 1 thru 5 or KEK (Channel 6).
(Star)	Ignore this key unless specifically directed by your SigO or NCS to use it. It serves no purpose during normal operation of SINCGARS radios. This is present on some models and not on others.
SYNC	Press this key to activate the passive late net entry feature of the SINCGARS radio.
<b>FREQ</b> (Frequency)	This key is used to check, load, clear, and offset SC frequencies; and to check and change net IDs.
<b>DATA</b>	Press this key to determine data status which can read: 600, 1200, 2400, 16000, AD1 (Analog Data 1), TF (TACFIRE), or OFF.
<b>ERF</b> (Electronic Remote Fill) (on same key as "OFST")	NCS operators press this key when sending a Cold Start or net update ERF to net operators. <u>It is not used by operators.</u>
<b>OFST</b> (Offset) (on same key as "ERF")	Used in conjunction with the FREQ and CHG buttons, this key enables the operator to offset SC frequencies by plus or minus 5 or 10 KHz. The offset feature of the SINCGARS radio can be used only in the SC mode.
<b>CHG</b> (Change)	When used in conjunction with the DATA, OFST, or CMSC keys, this button causes the display to scroll through available data or options.
<b>LOUT</b> (Lock Out)	This key is used only by NCS personnel and is rarely needed with current operating procedures. Operators may ignore this key.
<b>***TIME</b>	Press TIME once to see the Julian Date; press it a second time to see sync time hours and minutes; press a third time to see sync time in running minutes and seconds. Used in conjunction with the CLR and STO keys, the TIME button allows entry of sync time via the RT keypad.
<b>CLR</b> (Clear)	Used in conjunction with other keys, the CLR button enables the operator to delete entries or stored data.
<b>LOAD</b>	Used to load data into holding memory and to retrieve data from permanent memory. Also used to load radio.
STO (Store)	Press the STO key to place data into permanent memory of the RT Use of the STO key is the last step in various operator procedures.

KEYPAD BUTTON	PURPOSE
<p><b>BATT</b> (<b>Battery</b>) (on same key as "CALL" )</p>	<p>Used to check and set battery life condition in the manpack radio. When this key is pressed, the RT display shows battery life indication.</p>
<p><b>CALL</b> (on same key as "BATT" )</p>	<p>This key is used to communicate between the radio and an attached RCU. With FCTN set to REM and RT connected to the RCU, pressing CALL and PTT at the same time causes the RCU display to show "CALL," and an alarm is heard in the RT and RCU handsets.</p>

**5.3b. Technical**

**Receiver-Transmitter (RT) (SIP/ASIP)**

- Enhanced Data**                      The SIP/ASIP RT offers enhanced data rates of 1200N, 2400N, 4800N, and 9600N BPS, where the "N" indicates new or enhanced rates. The advantages of these enhanced data rates are better accuracy, great speed, longer range, and improved forward error correction.
- New Data Modes**                      Two new data modes are also provided: Packet (PCKT), which supports operations involving FBCB2 hardware and software, and RS-232 by which data messages can be sent from SIP/ASIP RT to SIP/ASIP RT using computers and commercial "Xmodem" communications software, a widely used file transfer protocol.
- RCU Function**                      The SIP/ASIP RT can be used as a remote control unit by merely selecting the "RCU" option under the [RCU] key of the SIP/ASIP RT keypad. The RCU, C-1 11561, can still be used to remotely control a SIP/ASIP radio for voice and SINGARS data modes, but it cannot be used for enhanced data modes.
- GPS Time Loading**                      An attractive feature of the SIP/ASIP RT is the ability to load GPS time from an attached PLGR using the very simple procedure.
- Internal FSK Detector**                      The SIP/ASIP RT contains an internal FSK detector circuit for use with the "AD1" and "TF" data rates. Use of a special CX-13808/U DMD interface cable is no longer necessary. In addition, TACFIRE devices must be cabled directly to the SIP/ASIP RT AUD/DATA connector,

**SIP/ASIP RT Keypad**

**General**

The keypad of the SIP/ASIP radio is similar to that of earlier versions except four of the keys have been given new designations: RCU, GPS, SA, and CID. The ASIP keypad adds a MENU and Backlight function. Each is explained below.

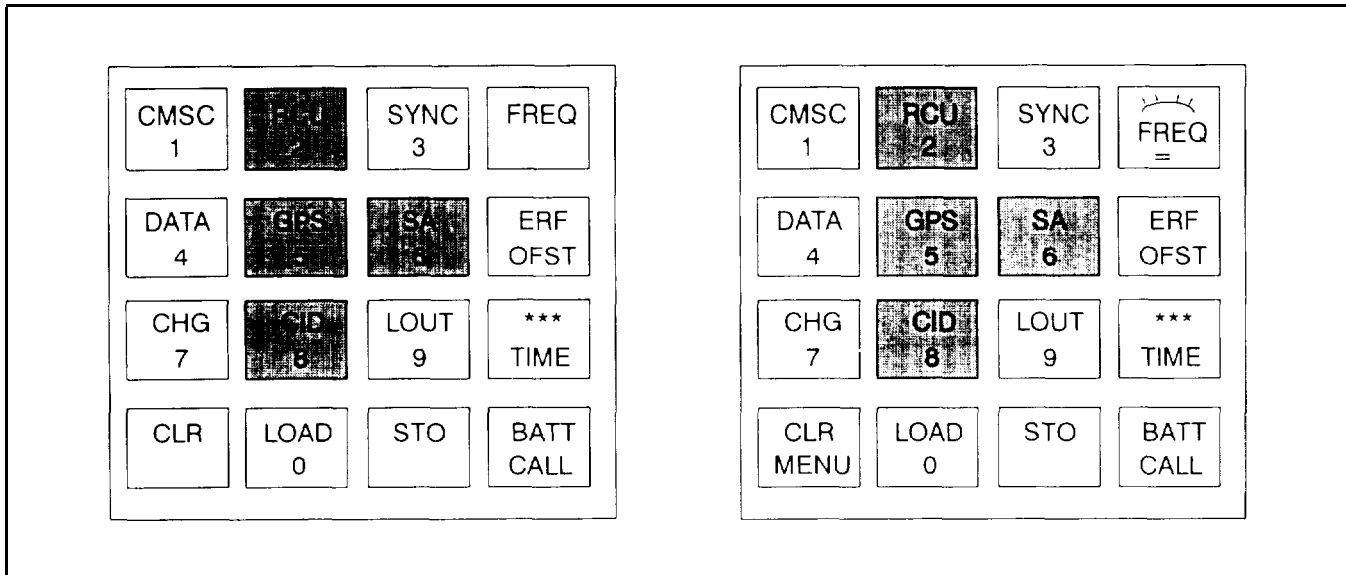

**Figure 5-1 1. SIP/ASIP KEYPADS**

**RCU(2)**

The RCU key is used to select operating mode options of RT, RCU, EXT, or LDE. RT is the normal employment of the RT as a receiver-transmitter. Selecting RCU allows the SIP/ASIP RT to be used as a remote control device. EXT, is a capability of the SIP/ASIP radio that allows the radio to be controlled externally via the system connector. The ASIP radio is automatically in EXT when proper Interface and software IS detected. Selecting EXT disables the front panel controls of the RT. EXT is used for GRM - 122 testing. LDE stands for local data entry and represents a future capability of the SIP/ASIP RT to communicate with SIP/ASIP VAA regarding data loads and requirements. This feature is currently not used.

**GPS(5)**

Represents a capability of the SINCGARS SIP/ASIP radio.

**SA(6)**

Represents a capability of the SINCGARS SIP/ASIP radio.

**CID(8)**

Represents a capability of the SINCGARS SIP/ASIP radio.

**CLR/MENU**

MENU appears on SINCGARS ASIP when key is pressed. Multiple presses will scroll MENU.

**FREQ/BACKLIGHT**

ASIP radio must be in SQ ON, press key [FREQ], then CHG to change intensity.

Connectors, SIP RT

P1 (System)

The P1 systems connector is located on the back of the SIP RT. This connector provides RT power and signaling interfaces.

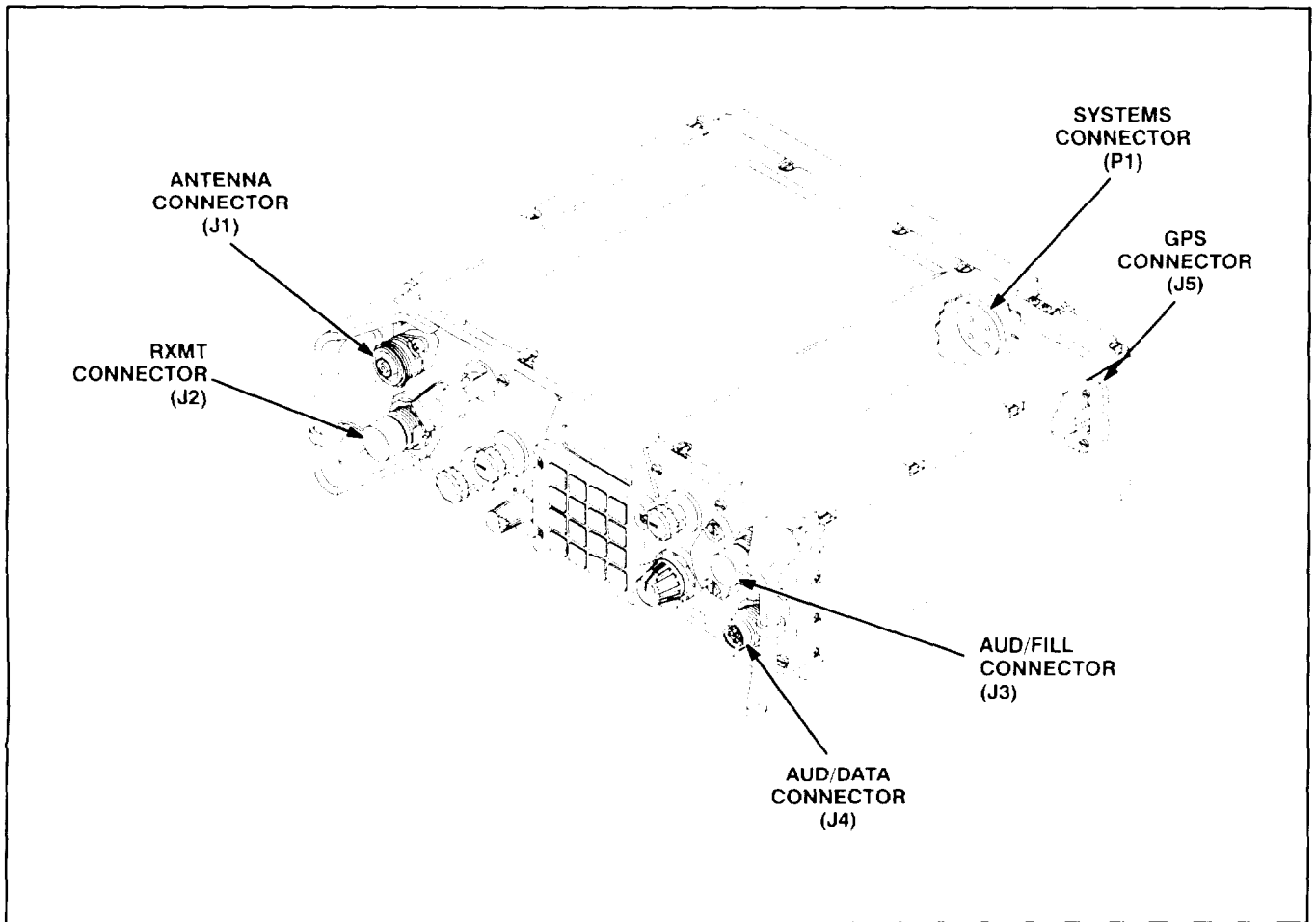

Figure 5-12. SIP RT Connectors

J5 (GPS)

Located on the back of the SIP RT the GPS J5 connector provides an interface of the VAA GPS connector.

J4 (AUD/DATA)

The J4 (AUD/DATA) connector supports general data communications at SINCGARS Data Rates of 600, 1200, 2400, 4800 and 16,000 BPS and Enhanced Data Rates of 1200N, 2400N, 4800N, and 9600N BPS. The RS-232 interface allows transmission of data via SINCGARS SIP radios using computers and commercial "Xmodem" software. If not using Packet (PKT) data mode, or the internet controller (INC) feature of the SIP radio, all data devices must be connected to the AUD/DATA port, not to the SIP VAA

J3 (AUD/FILL)

Handsets used with the SIP RT may be connected to the AUD/DATA or AUD/FILL connector. (NOTE: Handsets will not function if connected to the front of the SIP VAA.)

Connectors, ASIP RT

P1 (System)

This connector provides RT power and signaling interfaces

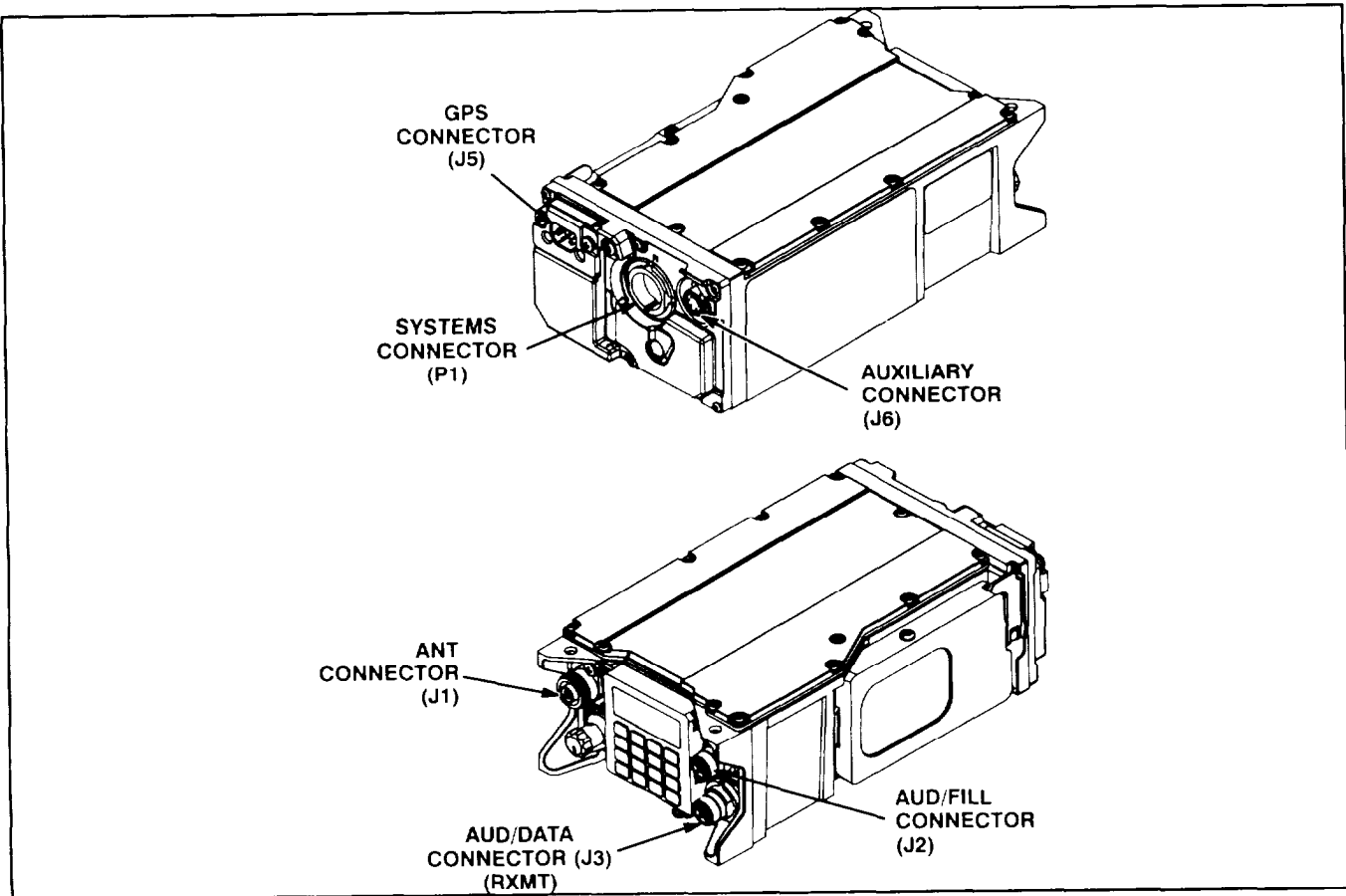

Figure 5-1 3. ASIP RT Connectors

**J6 (Auxiliary)**

Used to connect HRCRD handset and two-wire adapter.

**J5 (GPS)**

Enables a PLGR to be connected to a manpack radio.

**J3 (AUD/DATA)**

The J4 (AUD/DATA) connector supports general data communications at SINCGARS Data Rates of 600, 1200, 2400, 4800 and 16,000 BPS and Enhanced Data Rates of 1200N, 2400N, 4800N, and 9600N BPS. The RS-232 interface allows transmission of data via SINCGARS ASIP radios using computers and commercial "Xmodem" software. If not using Packet (PKT) data mode, or the internet controller (INC) feature of the ASIP radio, all data devices must be connected to the AUD/DATA port, not to the ASIP VAA.

**J2 (AUD/FILL)**

Handsets used with the ASIP RT may be connected to the AUD/DATA or AUD/FILL connector. (NOTE: Handsets will not function if connected to the front of the ASIP VAA.)

**J1 (Antenna)**

RF Input/Output

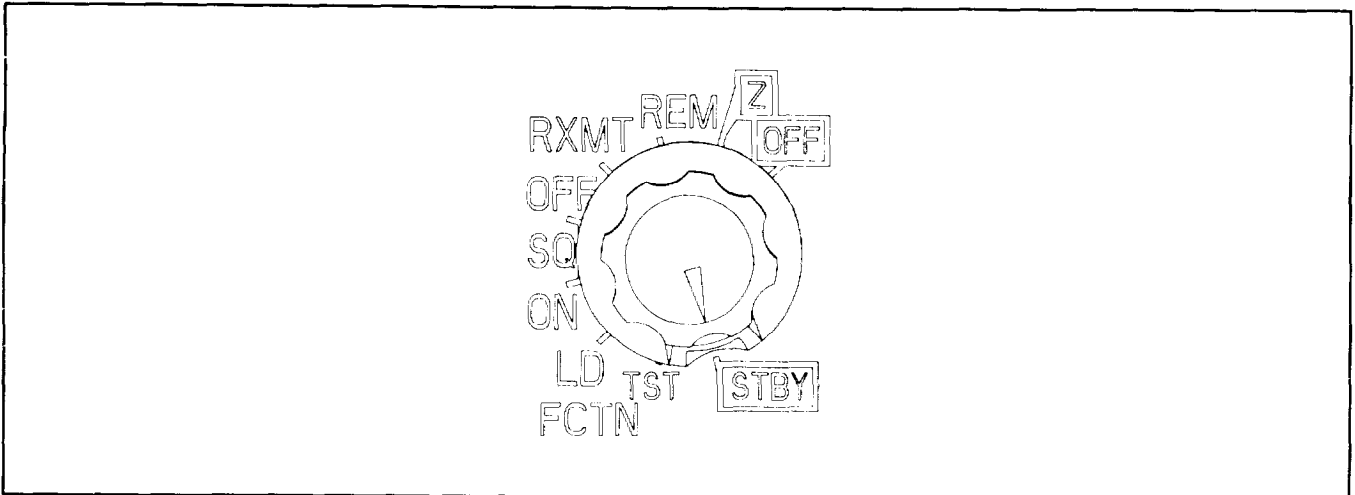

**Figure 5-14. ASIP RT FUNCTION SWITCH**

**FUNCTION CONTROL POSITIONS AND USES**

POSITION	PURPOSE
<b>OFF</b>	All power is shut off; all stored data, (COMSEC, FH, sync time, and manpack battery life indicator) are deleted after 5 seconds; radio is completely inoperable; position is used when radio is not in use and for storage.
(Zero)	Clears COMSEC, after 5 seconds clears all FH data; operator pauses in this position for 5 seconds when setting FCTN switch to OFF.
<b>STBY</b> (Stand By)	Makes radio inoperative but all stored data is retained; sync time is lost after 200 hours; setting FCTN to SQ ON returns radio to fully operational status. In STBY, power is drawn from main source.
<b>TST</b> (Test)	This position causes self-test of RT data and ECCM circuits; test results are shown in RT display. Running RT self-test is a routine step in start up procedure.
<b>LD</b> (Load)	The load position is required for loading SC frequencies, FH data, and COMSEC keys; required also to receive an ERE
<b>SQ ON</b> (Squelch On)	This is the normal operating position of the radio for FH mode. For SC mode, this position reduces noise.
<b>SQ OFF</b> (Squelch Off)	This position is not used for the FH mode. In the SC mode, SQ OFF helps to bring distant stations, to work through jamming, and to be compatible with radios lacking squelch capability.
<b>REM</b> (Remote)	The REM position disables front panel controls and is required for use of the Control-Monitor, Remote Control Unit (RCU) and HRCRD.
<b>RXMT</b> (Retransmit)	Use of the RXMT position enables the RT to automatically retransmit traffic from one radio through another. Both RTs are set to RXMT position and connected by an RXMT cable.

**SIP/ASIP VAA**

**Memory**

The SIP/ASIP VAA contains a small microprocessor which allows data in the form of routing tables to be stored.

**Internet**

When used in conjunction with FBCB2 hardware and software, the SIP/ASIP VAA supports internet communications among SINCGARS FH nets and between SINCGARS and EPLRS nets. Employment of the internet feature requires that the SIP/ASIP RT be set to the Packet data mode.

**5.3c. Remote Control Unit (RCU) Controls**

**FRONT PANEL**

The front panel of the RCU is quite similar to that of the RT. There is one additional control, an ON-OFF speaker switch. The only other difference is that the REM position of the RT FCTN switch becomes ICM (intercom), used for talking with the radio operator over the connecting field wire. RCU operator may call RT operator by setting FCTN to ICM and pressing CALL and PTT at the same time

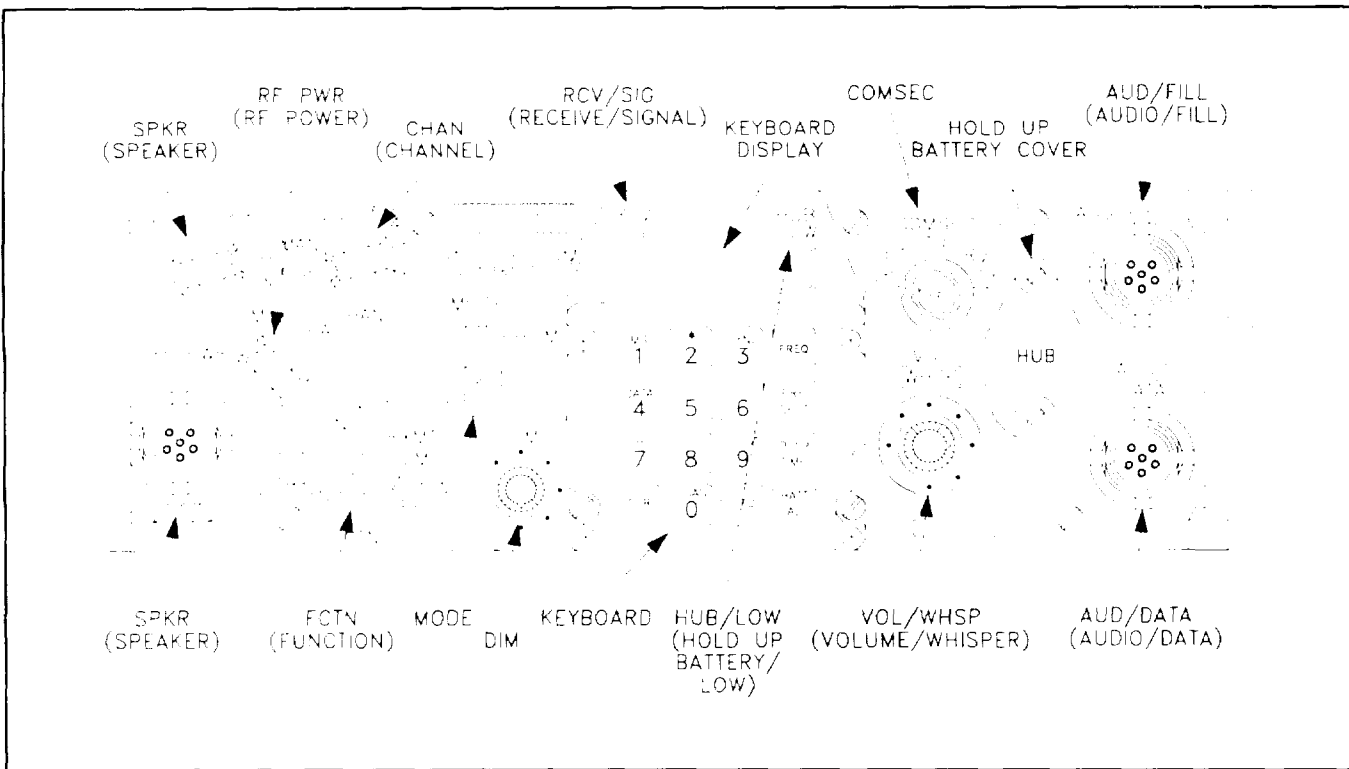

**Figure 5-15. RCU FRONT PANEL**



**5.3d. Automated Net Control Device (ANCD) Controls**

**KEYPAD**

The ANCD keypad provides the operator a 35 button keypad for communications with the ANCD. The function of each key is briefly explained below.

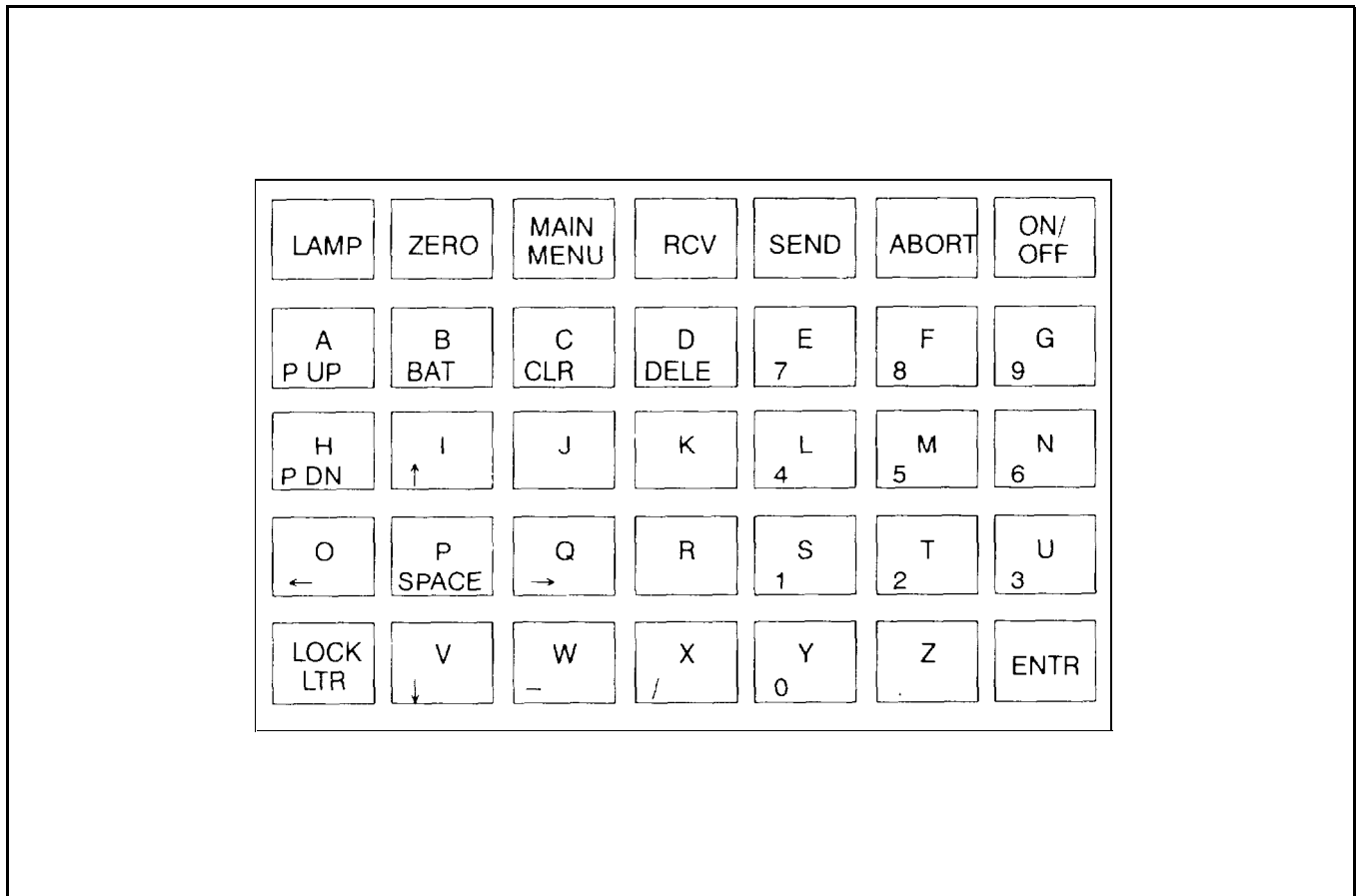

**Figure 5-16. ANCD Keypad**

**ANCD KEYPAD BUTTONS AND USES**

BUTTON	PURPOSE
A thru Z	Pressing these keys enters letters of the alphabet when LOCK LTR key is activated.
0 thru 9	Pressing these keys enters numbers when LOCK LTR key is deactivated.
LAMP	This key activates internal ANCD light for use with night vision goggles; lamp is not intended for use with naked eye.

BUTTON	PURPOSE
<b>ZERO</b>	This key is used in combat emergency situations to delete all data from the ANCD. DO NOT use the ZERO key for routine deletion of data.
<b>MAIN MENU</b>	Pressing this button returns ANCD display to the main menu; provides a quick and easy way to return to the start point of your procedure. (Will take operator to the RDS main menu if RDS is the default application, not your starting point.)
<b>RCV</b> (Receive)	Pressing this button at the proper time during data transfers causes the data to enter the target ANCD.
<b>SEND</b>	Pressing this button at the proper time during data transfers causes data to be sent from the source to the target ANCD.
<b>ABORT</b> (Abort)	This button is used to cause program being used to return to the preceding display.
<b>ON/ OFF</b>	This is a simple on-off control by which the ANCD may be readily activated and deactivated.
<b>P UP</b> (Page UP)	This key is used for scrolling and in some cases is required in lieu of up and down arrows.
<b>BAT</b> (Battery)	This key is not used. Low battery light comes on automatically when batteries become weak.
<b>CLR</b> (Clear)	Not used routinely; when prompted to do so, press this key to acknowledge receipt of message or confirm successful operation.
<b>DELE</b> (Delete)	This button may be used to delete individual characters when data is being manually entered into the ANCD. Also used to delete SOI sets.
<b>P DN</b> (Page Down)	This key is used for scrolling and in some cases is required in lieu of up and down arrows.
<b>SPACE</b>	This key is used to enter a space and may be used to erase characters during data entry.
<b>LOCK LTR</b> (Lock Letter)	When this key is activated, the word "LETTER" appears near the bottom left of the display, and letters may be entered. To use numbers and bottom level items, press LOCK LTR again; word "LETTER" disappears from the ANCD display.
<b>ENTR</b> (Enter)	Use this key to select item, enter data, and to continue to the next step in an operator procedure.

**5.3e. Precision Lightweight GPS Receiver (PLGR) Controls**

**KEYPAD**

The PLGR keypad provides 12 buttons through which the operator exercises control. This paragraph will discuss only those keys which the SINCGARS operator may use to check and load radio sync time, and to load PLGR keys from an ANCD. For navigational functions, see PLGR manuals.

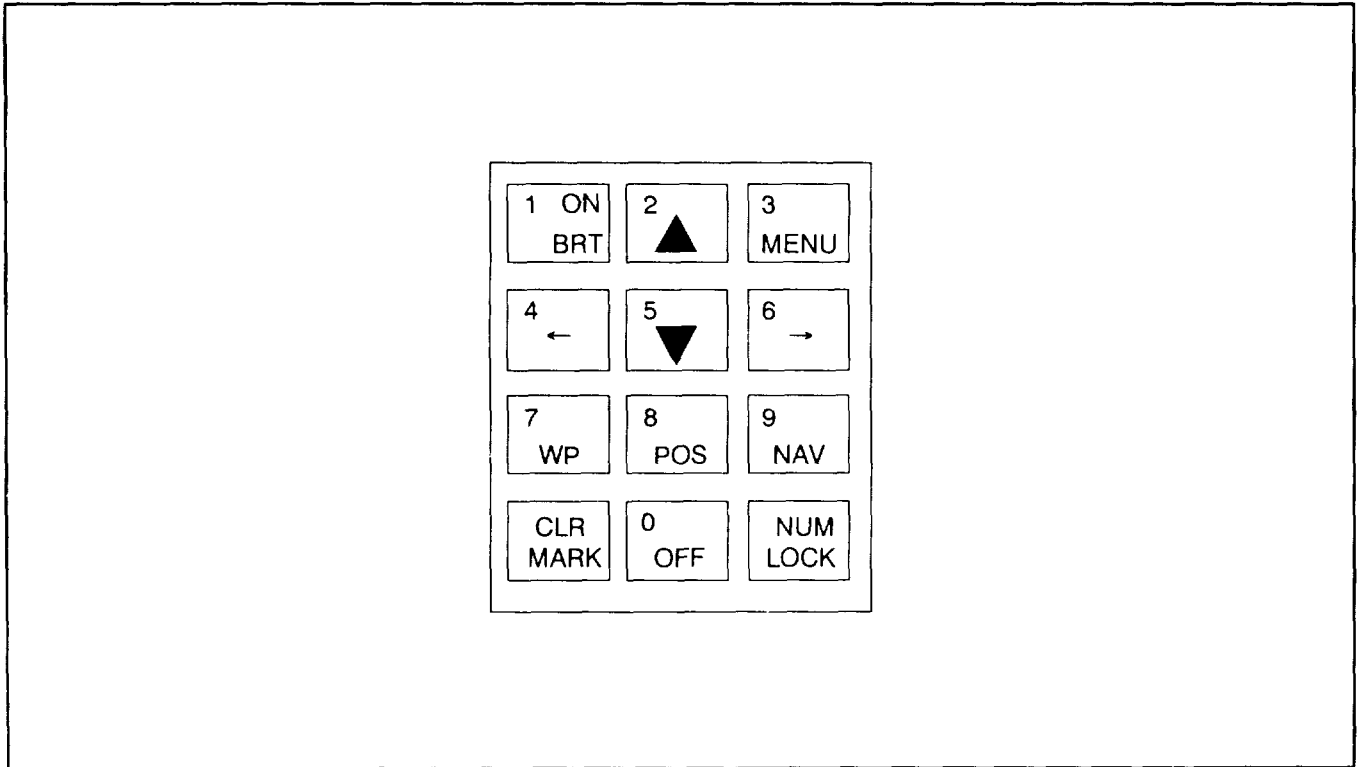

**Figure 5-17. PLGR KEYPAD**

**PLGR KEYPAD BUTTONS AND USES**

<b>BUTTON</b>	<b>PURPOSE</b>
<b>0 thru 9</b>	These keys are used to enter numbers.
<b>ON/BRT</b> (On/Bright)	Pressing the ON/BRT button once turns the PLGR on; holding this key down with PLGR on enables the operator to adjust the display backlighting using up/down arrows.
<b>UP ARROW</b> <b>DOWN ARROW</b>	These keys are used to change display pages, change number/alpha field values, activate functions, and adjust brightness.
<b>LEFT ARROW</b> <b>RIGHT ARROW</b>	These keys are used to move the cursor from field to field in the display.
<b>MENU</b>	Pressing the MENU key once displays first page of the system menu; pressing it a second time displays the second page.

BUTTON	PURPOSE
<b>WP</b> (Waypoint)	Pressing the WP key causes the Waypoint menu to be displayed.
<b>POS</b> (Position)	Pressing the POS key allows the Position display to be viewed.
<b>NAV</b> (Navigation)	When waypoints are loaded, pressing the NAV key allows Navigation displays to be viewed; without waypoints loaded, NAV key does not work.
<b>CLR</b> (Clear)	With the keypad in numeric lock, the CLR key is used to move the cursor to the left erasing wrong entries.
<b>MARK</b>	The MARK key is used to store present position as a waypoint.
<b>OFF</b>	Pressing the OFF key once starts a 30-second shut down process; pressing it a second time shuts down the PLGR immediately.
<b>NUM/LOCK</b> (Number Lock)	Pressing NUM LOCK toggles the keypad between control and numeric modes. An "N" is displayed at lower right when NUM LOCK IS on.

**5.3f. Control-Monitor (C-M)**

**FRONT PANEL**

The front panel of the Control-Monitor provides the operator four controls and five small displays for control of up to three radios. Controls include FCTN (function), RADIO, INIT (initiate), and DIM switches. The five displays show RF power, RT mode, channel, variable, COMSEC mode, and Main-Standby Control.

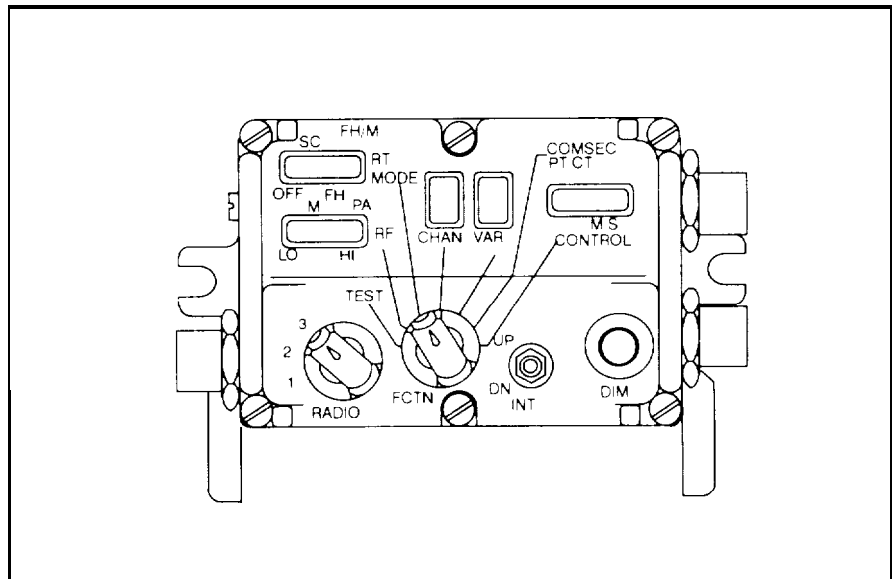

**Figure 5-1 8. CONTROL-MONITOR**

**CONTROL-MONITOR CONTROLS AND USES**

<b>CONTROL</b>	<b>PURPOSE</b>
<b>RADIO</b>	This control is used to select Radio 1, 2, or 3. Positions 1 and 2 are for RT-A and RT-B in first VAA; position 3 is for RT-A in second VA4
<b>FCTN</b> (Function)	This control is used for selecting test, RF power, RT mode, channel, COMSEC variable, COMSEC mode, and main or standby status.
<b>TEST</b>	Used to run C-M self-test. Results are shown in displays. Self-test will continue until FCTN switch is moved out of TEST position.
<b>RF</b> (Radio Frequency)	This control position is used to set the RF power output of the radio. The INIT switch is used for adjusting power.
<b>RT MODE</b>	Used to set RT mode, including power off. INIT switch is used to make changes. RT mode display shows operating mode.
<b>CHAN</b> (Channel)	Used to select RT channel, including CUE and MAN. Channel display shows channel selected; with "0" for MAN and "C" for CUE.
<b>VAR</b> (Variable)	Used to select COMSEC keys.
<b>COMSEC</b>	Used to select COMSEC mode, plain text or cipher text. COMSEC display shows PT or CT.
<b>CONTROL</b>	Used to change C-M from standby (S) to main (M). INIT switch is used to make changes. Control display shows operating condition.
<b>INIT</b> (Initiate)	Used with FCTN switch to change functions of RT and C-M. Moving INIT switch up moves FCTN display to right, or increases channel number. Moving INIT switch down moves FCTN display to left, or decreases the channel number.
<b>DIM</b>	This control adjusts brightness of displays. Turning it clockwise brightens displays; counterclockwise dims displays. DIM control is turned fully counterclockwise for use of night vision goggles.

**15.39. Loudspeaker (LS-671)**

**CONTROLS**

There are only two controls for the LS-671, plus a power indicator lamp. The LS-671 allows the SINCGARS operator to perform two functions from the loudspeaker: turn the radio on and off; and adjust the volume level of the handset and speaker.

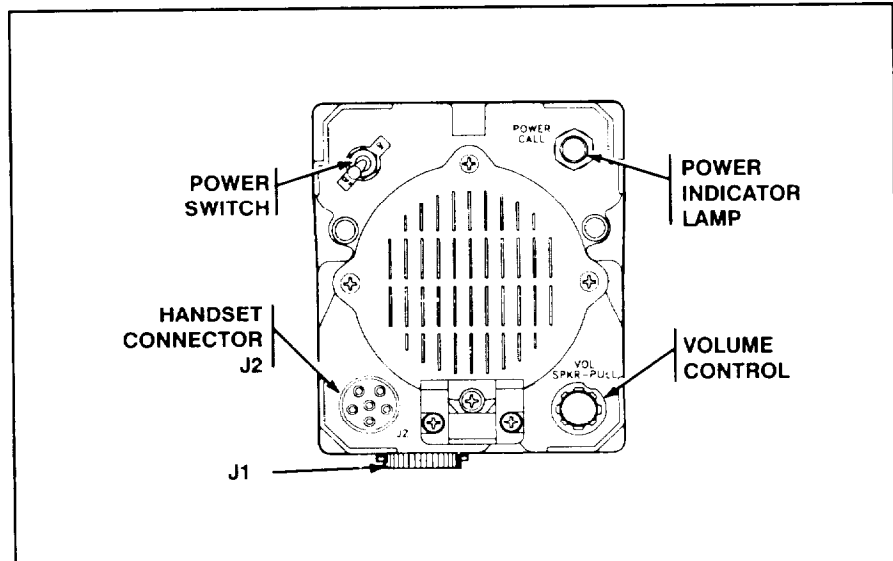

Figure 5-19. Loudspeaker LS-671

**LOUDSPEAKER LS-671 CONTROLS AND USES**

CONTROL	PURPOSE
<b>POWER SWITCH</b>	This switch enables the SINCGARS radio operator to turn the radio on and off from the loudspeaker. VAA CB1 must be set to ON.
<b>VOLUME CONTROL</b>	When pushed in, this control adjusts the audio level of the handset. When pulled out, it adjusts the volume of the loudspeaker. Turning the control clockwise increases the volume; counterclockwise decreases it.
<b>POWER INDICATOR LAMP</b>	The Power Indicator Lamp lights when VAA CB1 is ON and LS-671 Power Switch is turned on.

**5.3h. Vehicular Intercommunications Set (VIC)**

**CONTROLS**

The main control box of the VIC (Audio Frequency Amplifier, AM - 1780) provides five controls for main power, intercom accent, radio transmission, and installation control. Crew boxes (C-2297 and C-2298) provide two controls each: a function selector switch and a volume control.

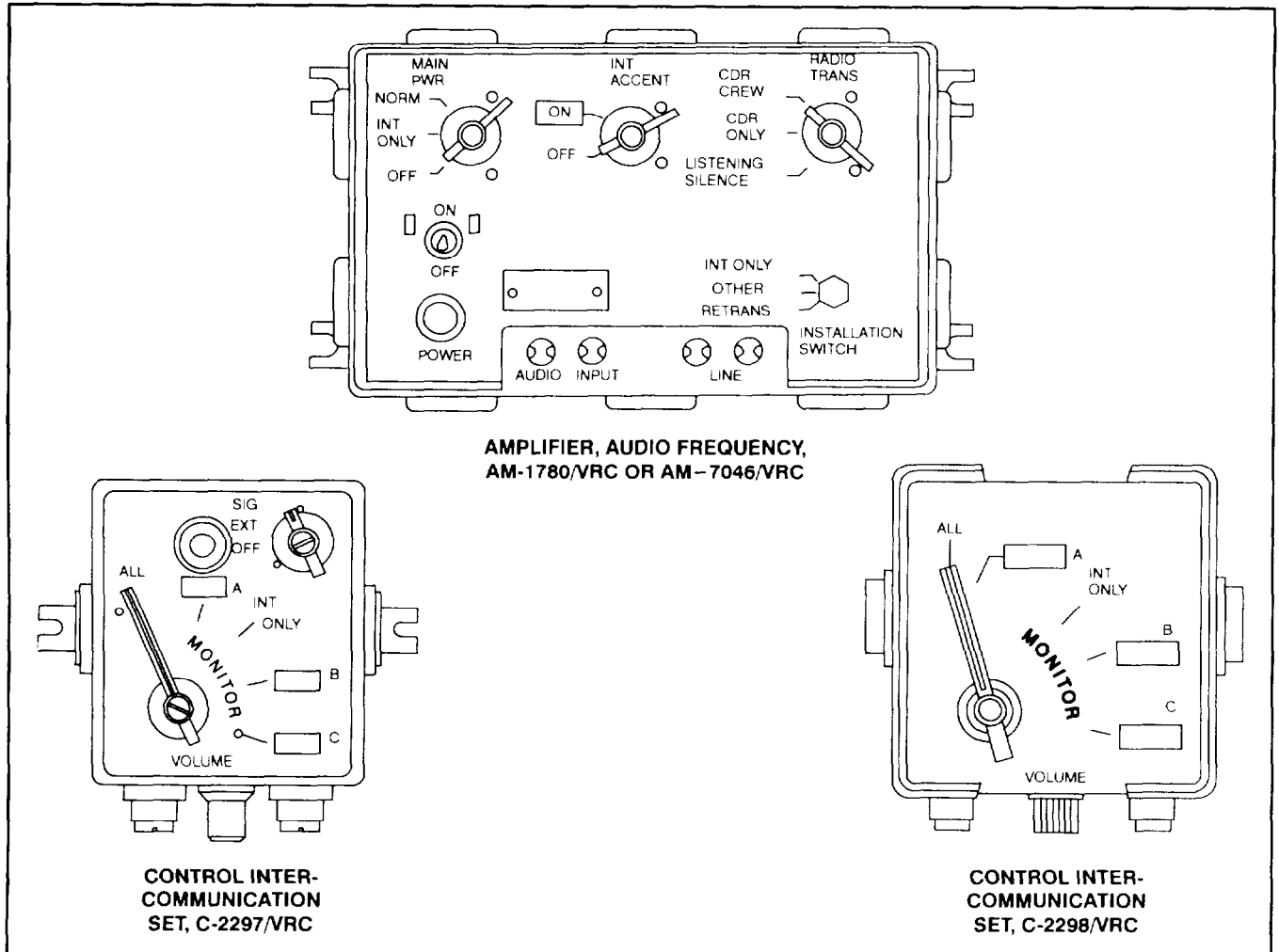

Figure 5-20. VIC CONTROLS

AM - 1780 CONTROLS AND USES

CONTROLS	PURPOSE
<b>POWER CKT BKR</b> (Circuit Breaker)	A two-position ON/OFF switch allows the user to initiate and terminate power to the VIC system.
<b>ON/OFF</b>	Supplies power to and removes power from crew boxes (C-2297 and C-2298).
<b>MAIN PWR</b> (Main Power)	This switch provides three power settings: normal, intercom only, and OFF.
<b>OFF</b>	Removes all power from the VIC and radio system.
<b>INT ONLY</b> (Intercom Only)	Allows communications among crewmembers, but does not allow use of radios.
<b>NORM</b> (Normal)	Supplies power to intercom and radios and is the normal position used for VIC.
<b>INT ACCENT</b> (Intercom Accent)	When ON, this switch reduces the volume level of radio traffic; intercom volume level remains unchanged.
<b>RADIO TRANS</b> (Radio Transmission)	This switch allows selection of transmit capabilities or listening silence.
<b>CDR+CREW</b>	Allows all crewmembers to transmit on radios.
<b>CDR ONLY</b>	Allows commander only to transmit on radios.
<b>LISTENING SILENCE</b>	Prevents transmission on radios.
<b>INSTALLATION</b>	This three-position switch is for use of maintenance personnel only. Crewmembers should not move switch setting.



**CREWBOX (C-2297&C-2298) CONTROLS AND USES**

<b>CONTROLS</b>	<b>PURPOSE</b>
<b>FUNCTION SELECTOR</b>	This primary switch controls access to intercom and radios "A" and "B" .
<b>ALL</b>	Crew can : Talk and listen on Intercom, Talk and listen on radio "A" , and Listen only on radio "B" .
<b>A</b>	Crew can: Talk and listen on Intercom, and Talk and listen on radio "A" .
<b>B</b>	This position is not used when the SINCGARS radio is used with the VIC system. Ignore the B position on crewboxes.
<b>C</b>	Commander can: Talk and listen on intercom, and Talk and listen on radio "B" . Other crewmembers can: Listen only on intercom, and Talk and listen on radio "B" .
<b>INT ONLY (Intercom Only)</b>	Crew can: Talk and listen on Intercom, but Cannot talk or listen on radios.
<b>VOLUME</b>	The volume control adjusts the audio level for headsets connected to that crewbox.
<b>SIG EXT OFF</b>	This control is used only in the "SIG" position. Other settings have no function with the SINCGARS radio.

## 5.4. PRIMARY OPERATOR/PREPARATION TASKS

### 5.4a. Definition of Primary Operator/Preparation Tasks

**WHAT ARE THEY?**

There are five tasks categorized as primary for the SINCGARS radio operator, manpack or vehicular and one preparation task for the ASIP radio. These tasks enable the operator to meet all normal communications requirements when the unit is in an operational situation.

**WHAT' S INVOLVED?**

These five primary tasks involve loading the radio with required single channel frequencies, COMSEC keys, FH data, and sync time. Additionally, they include the use of passive late net entry and the ANCD as the primary source of SOI information.

**WHAT' S REQUIRED?**

All SINCGARS radio operators are expected to be able to perform these five primary tasks without assistance, other than reference to TM11-5820-890-10-6 (Operator' s Pocket Guide). Operator Preventive Maintenance Checks and Services (PMCS) (see Chapter 8) are to be performed prior to performing these tasks.

### 5.4b. Summary of Primary Operator/Preparation Tasks

**PREPARATION TASK 1:**

**Select RT Preparation Setting from MENU**

Required to set the ASIP radio to proper settings for other tasks. MENU selections are Volume, Channel, Power, Mode and COMSEC. These settings will need to change as operationally necessary.

**PRIMARY TASK 1:**

**Load Single Channel Frequencies into RT**

Required for use of single channel communications, participation in Cold Start net opening, use of CUE and ERF method of late net entry, and single channel frequency updates.

**PRIMARY TASK 2:**

**Load COMSEC, FH Data, and Sync Time into RT Using ICOM Fill**

Required for secure, frequency hopping communications, participation in Hot Start net opening, COMSEC/FH data updates, and without sync time, participation in Cold Start net opening.

**PRIMARY TASK 3:**

**Perform Hot Start Net Opening**

Required when the net has been down, for any reason and for any period of time, and is now to become operational at a prescribed time. Operators load their RTs with all required COMSEC keys, FH data, and sync time. At the prescribed time, they call the NCS and enter the net. The Hot Start procedure may also be used when an individual operator has been out of the net for any reason and wishes to re-enter without resort to the CUE and ERF method of late net entry.

**PRIMARY TASK 4:**

**Perform Passive Late Net Entry**

Required when an operator's radio sync time becomes greater than plus or minus 4 seconds, but not more than one minute, different from net sync time. The Passive Late Net Entry process enables an operator to re-enter the net without requiring action on the part of the NCS or other net operators.

**PRIMARY TASK 5:**

**Obtain SOI information from ANCD**

SOI information electronically stored in the ANCD replaces the paper SOI extract. The ANCD SOI program is used when Information on nets, suffixes, pyro/smoke, sign/countersign is needed. It may be used to view quick reference (QREF) related items in group, time period, set, find, and memo. It may also be used to obtain the net ID of a net that is not a part of the loadset being used.

**5.4c. Select RT Preparation Settings from MENU (Preparation TASK 1)**

**DESCRIPTION**

This task is required to set the ASIP radio to proper settings for other tasks. MENU selections are Volume, Channel, Power, Mode and COMSEC. These settings will need to change as operationally necessary. The backlight function is also covered.

**DETAILED FLOWCHART**

**SELECT RT PREPARATION SETTINGS FROM MENU**

SUBTASKS	ACTIONS	RESULTS
a. Set RT Volume	(1) Press MENU (2) Press Digit (1 -9) for Vol Setting (0) for Whisper Mode	Press MENU to display Vol level Display reads WHSP if 0 selected
b. Set RT Channel	(1) Press MENU (until CHAN) (2) Press Digit (1-6) for Channel desired (0) for MAN (7) for CUE	Display reads (1-6), (Q) for CUE, (M) for Manual
c. Set RT Power	(1) Press MENU (until PWR) (2) Press CHG for desired PWR setting	Display reads (LO, M, HI, PA)
d. Set RT Mode	(1) Press MENU (until MODE) (2) Press CHG for desired MODE	Display reads (SC, FH, FHM)
e. Set COMSEC	(1) Press MENU (until CMSC) (2) Press CHG for desired CMSC setting	Display reads (PT, CT, TD, RV)
f. Set Backlight	(1) Place RT on SQ ON (2) Press FREQ/Backlight (3) Press CHG until desired setting	Backlight lights (4 settings Low to High, then OFF)

*Default Settings are: VOL (5), CHAN (1), PWR (LO), MODE (FH), COMSEC (CT)*

**5.4d. Load Single Channel Frequencies into RT (Primary Operator Task 1)**

**DESCRIPTION** The SINCGARS operator is required to perform this task in preparation for the employment of single channel communications, participation in Cold Start net openings, use of the CUE and ERF method of late net entry, and for single channel frequency updates. The operator determines the required single channel frequencies from the ANCD or another source. These frequencies are then loaded into the radio by use of the RT keyboard.

**DETAILED FLOWCHART** Operators perform the actions shown for each subtask, in the order shown below. Results are shown as ANCD display messages (dark bordered boxes) or as RT display messages in the form of "Display shows."

**LOAD SINGLE CHANNEL FREQUENCIES INTO RT**

SUBTASKS	ACTIONS	RESULTS
<b>a. Obtain required CUE, MAN, and/or SC freqs</b>	(1) Turn ANCD ON	select: <b>Soi</b> Radio sUpervisor
	(2) Enter SOI	qRef Group Net sufX Pyro <b>Tmpd</b> Set C/s Find Memo
	(3) Enter TMPD	Enter Time Pd: => ##
	(4) Select time period desired	<b>qRef</b> Group Net sufX Pyro Tmpd Set C/s Find Memo
	(5) Enter QREF	(Scroll to net desired; note SC freqs needed.)*
<b>b. Prepare RT for SC freq loading</b>	(1) Set COMSEC to PT	N/A
	(2) Set MODE to SC	
	(3) Set FCTN to LD	
	(4) Set CHAN to CUE, MAN, or CHAN 1-6	

SUBTASKS	ACTIONS	RESULTS
c. Load SC freqs*	(1) Press [FREQ]	RT display shows [00000] or [30000]
	(2) Press [CLR]	RT display shows
	(3) Enter 5-digit SC freqs	RT display shows [X X X X X]
d. Store SC freqs	Press [STO] (within 7 seconds)	RT display blinks once
e. Prepare to communicate (SC, PT)**	(1) Set FCTN to SQ ON	N/A
	(2) Set CHAN to CUE, MAN, or CHAN 1-6	N/A
	(3) Communicate in SC, PT mode when desired	N/A

\* ANCD contains CUE, MAN, and some SC frequencies. Other SC frequencies to be loaded in Channels 1-6 must be obtained from your NCS or SigO.

\*\* Operators normally do not load a CUE frequency; only NCS and alternate NCSs need to receive CUE messages. The MAN frequency must be loaded if the Cold Start net opening procedure is to be used. Channels 1 thru 6 are loaded with SC frequencies only when single channel communications are known to be mission requirements. In a typical frequency hopping net which uses the Hot Start net opening procedure, it is not necessary for the operator to load any SC frequencies, at least until a specific need arises.

**5.4e. Load COMSEC/FH Data/Sync Time into RT Using ICOM Fill  
(Primary Operator Task 2)**

**DESCRIPTION**

This task is required in preparation for a Hot Start net opening and, without sync time, for COMSEC/FH data updates. This task may also be performed in preparation for a Cold Start net opening by omitting sync time. Performance of this task involves the use of an ANCD as a source of COMSEC keys, FH data (hopset, TSK, and net ID), and sync time. By use of the ICOM fill procedure, COMSEC, FH data, and sync time are simultaneously loaded into all six channels of the SINCGARS radio. Upon completion of the ICOM fill, the radio is fully prepared for secure, frequency hopping communications.

**DETAILED FLOWCHART**

**LOAD COMSEC/FH DATA/SYNC TIME INTO RT USING ICOM FILL**

SUBTASK	ACTIONS	RESULTS
a. Prepare RT to receive an ICOM fill	(1) Set COMSEC to CT	(Press PTT twice to clear COMSEC alarm)
	(2) Set FCTN to LD	N/A
	(3) Set CHAN to MAN	N/A
	(4) Set MODE to FH	Display shows "FILL O"
	(5) Set DATA to OFF*	Display shows "OFF"

SUBTASK	ACTIONS	RESULTS
<b>b. Prepare ANCD to perform ICOM fill</b>	(1) Turn ANCD ON	select: SOi <b>Radio</b> supervisor
	(2) Enter RADIO	<b>Send</b> Receive Database sEtuP Comsec Time
	(3) Enter SEND	send to: <b>Radio</b> Ancd Stu PC
	(4) Enter RADIO	select: <b>iCom</b> Nonicom Abn Rcu** Haveq
	(5) Enter ICOM	Connect to RT AUD/FILL Connector [↓]
	(6) Connect ANCD to RT and press down arrow	Set FCTN switch to LD on RT
	(7) Ensure FCTN is at LD and press down arrow	Do you want to include time?*** (Y/N)
	(8) Enter YES	Press [LOAD] on RT
<b>c. Perform ICOM fill on RT</b>	(1) Press [LOAD] button on RT keypad and observe	Transfer in progress
	(2) Note completion of ICOM fill data transfer	ICOM transfer successful [↓]
	(3) Load sync time manually if required to do so	RT cannot accept time from ANCD****

\* DATA control is found on the same key as the numeral "4."

\*\* Select "Rcu" to fill a Remote Control Unit (RCU) with COMSEC keys. The procedure is the same as that shown for ICOM radio fill but only COMSEC is loaded, not FH data. (RCU does not require FH data.)

\*\*\* Sync time is normally included for net opening only, not for net updates. Consult your NCS or unit SOP for exact policy to follow.

\*\*\*\* If the RT being used willnot accept sync time as a part of the ICOM fill, this message will appear. When it does, the operator must then manually load Julian Date and sync time into the radio.

**5.4f. Perform Hot Start Net Opening (Primary Operator Task 3)**

**DESCRIPTION**

This task is required when the net has been down for any reason and is now to become operational at a prescribed time. This procedure may also be used when an individual operator has been out of the net for any reason and wishes to re-enter the net without resort to the CUE and ERF method of late net entry. This task involves two basic steps: loading the radio with COMSEC keys, FH data, and sync time by use of the ICOM fill procedure (Primary Operator Task 2); and calling the NCS in secure, frequency hopping mode to request net entry.

**DETAILED FLOWCHART**

**PERFORM HOT START NET OPENING**

SUBTASKS	ACTIONS	RESULTS
a. Load RT with COMSEC/ FH data/sync time	(1) Perform ICOM Fill (Primary Opr Task 2)	RT channels (6) are loaded with COMSEC/FH/sync time
	(2) Load sync time manually if required by RT version*	<b>N/A</b>
b. Enter net	(1) Call NCS using CT FH mode	N/A (NCS responds)
	(2) Request permission to enter the net	Hot Start net opening <i>is</i> completed for this operator

\* If the message "RT cannot accept time from ANCD" appears, go to subtasks c and d below to manually load Julian Date and sync time. Once that has been accomplished, contact your NCS and enter the net.



SUBTASKS	ACTIONS	RESULTS
<b>c. Load Julian Date (JD) in RT</b>	(1) Turn ANCD ON	select: Soi <b>Radio</b> sUpervisor
	(2) Enter RADIO in ANCD	Send Receive Database sEtap Comsec <b>Time</b>
	(3) Enter TIME in ANCD	Julian Day: X X  [↓]
	(4) Press TIME on RT keypad one time	RT display shows "D D"
	(5) Press CLR on RT keypad	RT display show "--"
	(6) Enter XX (JD from ANCD)	RT displays shows "XX"
	(7) Press STO on RT keypad	New Julian Date IS now stored in the radio
<b>d. Load Sync Time in RT</b>	(1) Press down arrow on ANCD (see c(3) above)	ANCD Time: (running) HH:MM:SS (eg, 22:45:15)
	(2) Press TIME on RT keypad (two times)	RT display shows "HH MM"
	(3) Press CLR on RT keypad	RT display shows - - - -
	(4) Enter HH from ANCD	RT display shows "HH"
	(5) Enter MM (minute ahead of ANCD time)	RT display shows "HH MM" (Do NOT press STO yet!)
	(6) Press STO on RT keypad*	When ANCD and RT time are at same MM, zero seconds
	(7) Compare RT time with ANCD time**	Manual loading of JD and sync time is completed

\* Time stored in the radio should be within one second of that in the ANCD: if not, repeat time loading procedure.

\*\* Press [TIME] three times.

**5.4g. Pet-form Passive Late Net Entry (Primary Operator Task 4)**

**DESCRIPTION**

This task is required when the sync time in your radio becomes more than 4 seconds (plus or minus), but less than one minute, different from net sync time. Passive late net entry enables an individual operator to re-enter the net without action on the part of the NCS or other net operators. This task makes use of a feature built into the SINCGARS radio and involves but two steps: placing the RT in passive late net entry mode; and waiting for the radio to adjust its sync time to that of the net. When this method of late net entry does not work, the Hot Start procedure or CUE and ERF method of late net entry should be used.

**DETAILED FLOWCHART**

**PERFORM PASSIVE LATE NET ENTRY**

SUBTASKS	ACTIONS	RESULTS
a. Note that no traffic is being heard on the net	Try to contact the NCS or another net station	There IS no response to your calls
b. Prepare radio for passive late net entry	(1) Press FREQ on RT keypad	RT display shows " F XXX"
	(2) Press SYNC on RT keypad	RT display shows " LF XXX"
c. Allow RT to make automatic adjustment	(1) DO NOT press PTT while RT is in this mode	Rt display Will continue to show " LF XXX"
	(2) Wait until you hear traffic on the net*	RT will drop "L" from display (will read " F XXX" again)
d. Re-establish contact with net NCS	Call NCS and re-enter the net	Passive method of late net entry is completed

\* If traffic is not heard after using the Passive Late Net Entry method *for three* minutes or so, use the *Hot Start procedure* or *CUE and ERF method of late net entry*

**5.4h. Obtain SOI Information from ANCD (Primary Operator Task 5)**

**DESCRIPTION**

Because the ANCD replaces the paper SOI, the operator performs this task whenever SOI information on nets, suffixes, pyrotechnics, smoke, or sign/countersign is required. As many as 40 Quick Reference (QREF) items can be made available to the operator in list form. Full SOI information is readily available for all QREF entries. Up to five time periods (24-hour days) may be included in each QREF file. Performance of this task involves turning on the ANCD, selecting the SOI program, entering QREF and scrolling to the element of SOI information desired.

**DETAILED FLOWCHARTS**

1. Rules to remember in obtaining SOI information from the ANCD are:

ACTION	RESULT
ABORT	Causes ANCD to return to SOI menu
Arrow down [↓]	You must press arrow down to go to the next screen
Arrow right/arrow left	Allows viewing of additional information and return
Arrow up/arrow down	Allows viewing of each item
DELETE	To delete SOI set, enter SOI, then Set, and press DELE key
ENTER (shown as ENTR)	Causes activation of the entry you have selected
Hot keys	Capital letter of item selected, eg, sufX; allows direct shift from QREF to full SOI file
“ J” key (for JUMP)	In Find, causes ANCD to continue search for next item
“ K” key (for KEEP)	Causes item being viewed to be stored in QREF file
MAIN MENU	Returns you to SOI/RADIO/SUPERVISOR menu

ACTION	RESULT
PgUP/PgDN	Moves you to top or bottom of the list
ZERO (red button)	Used in combat emergency only; DO NOT use for deletions

2. To look up any of the up to 40 QREF items of SOI information contained in the QREF file. perform the following steps:

ACTION	RESULT
Turn ANCD <b>ON</b>	select: <b>Soi</b> Radio supervisor
Enter SOI	<b>qRef</b> Group Net sufX Pyro Tmpd Set C/s Find Memo
Enter <b>QREF</b>	Last QREF item viewed appears in ANCD display. Entering QREF brings to the display a list of up to 40 specific SOI items selected from NET, SUFX, PYRO, or C/S. Once the QREF file has been entered, scroll up or down to locate the SOI item desired. Additionally, all SOI information associated with each of these QREF Items is available by returning to the SOI menu (shown above) and entering GROUP TMPD, SET, FIND, or MEMO.

3. The following are examples of SOI information which may be available in a full SOI file:

- a. **GROUP:** Enter **Group** and scroll to the SOI item desired.

**(Group)**

qRef <b>Group</b> Net sufX Pyro Tmpd Set C/s Find Memo
TO1 Set: 52ID DEM 003 003 52ID SPT

b. **NET:** Enter **Net** and scroll to the SOI item desired.

(Net)

qRef Group Net sufX Pyro TmPd Set C/s Find Memo
T06 1-4 FA BN W7T C81975 M74800 0424
TO1 1-41 ADA CMD Y1Z Callwrd. BULLDOG*

\* *Cal/word is obtained by pressing right arrow, then left arrow to return to NET display.*

c. **SUFFIX:** Enter **sufX** and scroll to the SOI item desired.

(sufX)

qRef Group Net sufx Pyro TmPd Set C/s Find Memo
Commander 02 COFS/XO 27

\* *Expanders are found at the end of suffixes.*

d. **PYRO/SMOKE:** Enter **Pyro** and scroll to the SOI item desired.

(Pyro)

qRef Group Net sufX <b>Pyro</b> TmPd Set C/s Find Memo
GREEN SMOKE
Safe to land or drop supplies here*

\* *Meaning of GREEN SMOKE can be obtained by pressing right arrow, then left arrow to return to Pyro menu. You may scroll through signals or meanings, as desired, by pressing up/down arrows.*

e. **TIME PERIOD:** Enter **Tmpd** and scroll to the SOI item desired.

**(Tmpd)**

qRef Group Net sufX Pyro <b>Tmpd</b> Set C/s Find Memo
Enter Time Pd: => ##

f. **SET:** Enter **Set** and scroll to the SOI item desired.

**(Set)\***

qRef Group Net sufX Pyro Tmpd <b>Set</b> C/s Find Memo
select: Choose Send Receive
Scroll ↓/↑ press ENTR to select SOI set [↓]
Set: (name/nr) Edn: (name) TP: (nr)

\* A **SET** may be deleted by entering **Set** and pressing the ANCD DELE (delete) key

g. **SIGN/COUNTERSIGN:** Enter **C/s** to view sign/countersign for current time period. To view sign/countersign for other time periods, go to **Tmpd** and enter time period desired

**(C/s)**

qRef Group Net sufX Pyro Tmpd Set <b>C/s</b> Find Memo
TO1 Sign: HARDWOOD Cntrsign: SNEAKER

**h. FIND:**

Enter **Find**; then select the category of SOI item desired. If the first item viewed is not the desired one, press “J” (for JUMP) to cause the ANCD to continue to search for the SOI item you want to see.

**(Find)**

qRef Group Net sufx Pyro TmPd Set C/s <b>Find</b> Memo
Find: Net nEtId Sfx Word Clsgn Grp gRp# Des Frq

**i. MEMO:**

Enter **Memo** and select the memo number desired. (Each of four memos may be six lines long, with 22 spaces on each line.) Memos are available in QREF files as well as full SOI files. They may be transferred from ANCD to ANCD in both full and QREF transfers. You may both create and read memos.

**(Memo)**

qRef Group Net sufX Pyro TmPd Set C/s Find <b>Memo</b>
Memo: 1–                      2– 3–                      4–

## **5.5. SPECIAL OPERATOR TASKS**

### **5.5a. Definition of Special Operator Tasks**

#### **WHAT ARE THEY?**

There are eight tasks categorized as special for the SINCGARS/ANCD operator. They are “special” in that they may be performed by specially trained operators, or they may be the responsibility of communications specialists, NCSs, or designated NCOs. These eight tasks are normally not required of the SINCGARS/ANCD operator to meet routine communications requirements when the unit is in an operational situation. Some operators may be required to perform some of these special tasks while other unit operators will not be.

#### **WHAT’ S INVOLVED?**

These special tasks involve functions that are required only occasionally by selected stations. An example is the commander’ s driver who may be called upon to transfer data from one ANCD to another. The commander’ s driver might also be required to change net IDs. Also, unit scouts may be required to perform retransmission operations.

#### **SPECIAL OPERATOR TASKS (SIP/ASIP)**

In addition to the eight special operator tasks, there are two Special SIP/ASIP Operator Tasks. These special SIP/ASIP tasks are: use the SIP/ASIP RT as an RCU; and send data from one computer to another over a SINCGARS secure, frequency hopping net using the RS-232 enhanced data feature.

#### **WHAT’ S REQUIRED?**

All unit NCS personnel should be able to perform these special as well as primary operator tasks. Training in special operator tasks is an inherent part of unit sustainment training and is conducted on a small group or Individual basis related to unit mission requirements.



## 5.5b. Summary of Special Operator Tasks

### SPECIAL TASK 1:

#### **Transfer COMSEC/FH Data/Sync Time, ANCD to ANCD**

This task is used when individual operators are required to load their own ANCD with COMSEC keys, FH data, and sync time from one being passed around the unit. (Many unit SOPs call for communications specialists or designated NCOs to perform this task for operators. This task is performed prior to net openings and during periodic ANCD data updates.

### SPECIAL TASK 2:

#### **Transfer QREF SOI Information, ANCD to ANCD**

This task is similar to Special Task 1 but differs in the procedure followed. It is performed prior to net openings and during periodic ANCD data updates. (Unit SOP determines whether operators, communications specialists, or designated NCOs are responsible for the function.)

### SPECIAL TASK 3:

#### **Perform Cold Start Net Opening**

If an NCS finds it necessary to use the Cold Start method of net opening, it is essential that operators be trained in this task. This task is "special" in that it is unlikely the Cold Start net opening procedure will be used frequently.

### SPECIAL TASK 4:

#### **Receive Net Update ERF from NCS**

This task is performed when an NCS needs to update some element of FH data, including sync time, using electronic transfer means. The normal method of FH data updating is by physical connection of one ANCD to another. ERF update provides a back-up procedure for those occasions when electronic transfer is required by the tactical situation of the unit.

### SPECIAL TASK 5:

#### **Perform CUE and ERF Method of Late Net Entry**

This task is performed when sync time in the RT becomes, for any reason, more than one minute different from that of the operational net. Use of the CUE and ERF method is discouraged because it requires single channel communication and special action on the part of the receiving NCS. The Hot Start procedure works equally well, and it does not involve SC mode or NCS action. (For RT-1523A/B versions, sync time difference cannot exceed 100 days; for the RT- 1523 version, difference cannot exceed 60 minutes.)

### SPECIAL TASK 6:

#### **Conduct Retransmission (RXMT) Operations**

Performance of this task is required when one or more stations of a net become out of normal SINCGARS operating range or an obstacle blocks line of sight communications, This is a task that unit scouts, staff vehicle drivers, and communications specialists should be able to perform on short notice. The RXMT capability of the SINCGARS radio is of significant value in various operational situations.

**NOTE**

DATA RXMT: All data rates except PCKT may be retrains with the following provisions.

1. SDM data, TF and AD1 : No change to normal retrains procedures. Radios do not have to be set in Data mode (data off). Mixed radios at RXMT site or outstations is permitted.
2. EDM DATA: Radios at the RXMT site have to be set to the same EDM data rates as outstations. Only SIP radios can be used at the RXMT site and outstations.

**SPECIAL TASK 7:**

**Send an ERF as Part of RXMT Operation**

This task is required only as a part of RXMT operations. In some situations, it may be necessary for the RXMT operator to send an ERF to the distant station before retransmission can be started. Any operator held responsible for performing Special Task 6 should also be trained in this task.

**SPECIAL TASK 8:**

**Change Net ID**

When contact with a non-loadset (not loaded in radio Channel 1 through 6) station is desired, the operator needs to be able to change to the net ID of the desired station.

**SPECIAL TASK 9:**

**Use SIP RT as an RCU**

Allows the operator to use the SIP RT as either a Manpack RCU or remoted radio.

**SPECIAL TASK 10:**

**Send Data Via RS-232 Mode**

Allows the operator to use any one of four enhanced data rates to transmit and receive data messages using RS-232 mode.

**5.5c. Transfer COMSEC Keys/FH Data/Sync Time, ANCD to ANCD (Special Operator Task 1)**

**DESCRIPTION**

During preparations for net opening and during periodic updating of COMSEC keys, FH data, and sync time stored in the ANCD, it is necessary to transfer data from one ANCD to another. If such transfers are not made by communications specialists or designated NCOs, operators must be able to perform this special task.

**DETAILED FLOWCHART**

Operators perform the actions required in each subtask, in the order shown. Results are shown as ANCD displays (dark bordered boxes: or as RT displays in the form of "RT display shows..." Where appropriate, results are expressed as explanations of occurrences.

SUBTASKS	ACTIONS	RESULTS
<p><b>a. Prepare Source ANCD for COMSEC/FH transfer</b></p>	<p>(1) Turn Source ANCD ON</p>	<p>select: Soi <b>Radio</b> sUpervisor</p>
	<p>(2) Enter RADIO</p>	<p><b>Send</b> Receive Database sEtop Comsec Time</p>
	<p>(3) Enter SEND</p>	<p>send to: Radio <b>Ancd</b> Stu PC</p>
	<p>(4) Enter ANCD</p>	<p>Loadset <b>Database*</b> Time Key Eset Mwod**</p>
	<p>(5) Enter DATABASE</p>	<p>Do you want to include time?  (Y/N)</p>
	<p>(6) Respond YES</p>	<p>Connect to ANCD and press [SEND] <b>(WAIT)***</b></p>
<p><b>b. Prepare Target ANCD for COMSEC/FH transfer</b></p>	<p>(1) Turn Target ANCD ON</p>	<p>select: Soi <b>Radio</b> sUpervisor</p>
	<p>(2) Enter RADIO</p>	<p>Send <b>Receive</b> Database sEtop Comsec Time</p>
	<p>(3) Enter RECEIVE</p>	<p>receive: <b>Ancd</b> Cfd Stu PC Mx</p>

SUBTASKS	ACTIONS	RESULTS
	(4) Enter ANCD	Loadset <b>Database*</b> Time Key Eset Mwod**
	(5) Enter DATABASE	Do you want to delete FH and COMSEC data?**** (Y/N)
	(6) Respond YES	Connect to ANCD and press [RCV] <b>(WAIT)***</b>
<b>c. Transfer COMSEC/FH Data/Sync Time</b>	(1) Press [SEND] on Source ANCD	Transfer in progress
		Transfer successful
	(2) Within 20 seconds, press [RCV] on Target ANCD	Transfer in progress
		Transfer successful

\* You must enter "DATABASE" in order to proceed.

\*\* MWOD (Multiple Word Of Day) is a term used in the loading procedure for the Have Quick radio found in selected aircraft.

\*\*\* **Do not** press [SEND] on Source ANCD until you are ready to press [RCV] on Target ANCD; then press [RCV] within about 20 seconds of pressing [SEND].

\*\*\*\* You must enter YES in order to proceed.

NOTE: You can clear your ANCD of COMSEC/FH data/sync time by performing steps b(1) through b(5), above.

**5.5d. Transfer QREF SOI Information, ANCD to ANCD (Special Operator Task 2)**

**DESCRIPTION**

This task is required in preparation for unit operations. SOI information is passed from the brigade or higher LCU operator down to unit Signal Officers and NCSs who develop unit-specific Quick Reference (QREF) files for operator use.\* Dissemination within units is accomplished by transferring SOI information from one ANCD to another. When this special task is not performed by communications specialists or designated NCOs, operators must be trained to perform the data transfer. Operators who are expected to perform Special Operator Task 1 should also be trained in this task.

**DETAILED FLOWCHART**

SUBTASKS	ACTIONS	RESULTS
<p><b>a. Prepare Source ANCD for QREF SOI transfer</b></p>	(1) Turn ANCD ON	select: <b>Soi</b> Radio sUpervisor
	(2) Enter SOI	qRef Group Net sufX Pyro Tmpd <b>Set</b> C/s Find Memo
	(3) Enter SET	select: Choose <b>Send</b> Receive
	(4) Enter SEND	Scroll (↓/↑) and press ENTR to select SOI Set [↓]
	(5) Press down arrow and scroll to set desired	Set: (name/nr) Edn: (name/ (tp) [ENTR]
	(6) Press ENTR to select	Do you want to transfer QREF?*** (Y/N)
	(7) Respond YES	send to: <b>Ancd</b> Pc Broadcast Stu
	(8) Enter ANCD	Connect ANCD to ANCD [↓]
	(9) Connect ANCDs and press down arrow	Press [SEND] to send <b>(WAIT)***</b>

SUBTASKS	ACTIONS	RESULTS
<b>b. Prepare Target ANCD for QREF SOI transfer</b>	(1) Turn ANCD ON	select: <b>Soi</b> Radio supervisor
	(2) Enter SOI	qRef Group Net sufX Pyro Tmpd <b>Set</b> C/s Find Memo
	(3) Enter SET	select: Choose Send <b>Receive</b>
	(4) Enter RECEIVE	receive from: <b>Ancd</b> Pc Broadcast Stu
	(5) Enter ANCD	Connect ANCD to ANCD  [↓]
	(6) Press down arrow	Press [RCV] to receive <b>(WAIT)</b> ***
<b>c. Transfer QREF SOI from ANCD to ANCD</b>	(1) Press [SEND] on Source ANCD	Processing. Please wait. (shows % of bytes sent)
		Sending of SOI data is completed
	(2) Within 20 seconds, press [RCV] on Target ANCD	Processing. Please wait. (shows number of bytes sent)
		Receive operation was successful

\* To develop a QREF file, merely scroll to the SO/ items desired and press "K" (for KEEP) to place each item in the QREF file.

\*\* You must respond YES to proceed. (This screen appears only if a QREF file is stored in your ANCD.)

\*\*\* Do not press [SEND] on Source ANCD until you are ready to press [RCV] on Target ANCD; then press [RCV] within about 20 seconds of pressing [SEND].

NOTE: See Special Operator Task 2 (Alternate) if you wish to transfer a full SOI information file.

**5.5e. Transfer Full SOI Information, ANCD to ANCD  
(Special Operator Task 2 Alternate)**

**DESCRIPTION**

Although the principal SOI transfer task involves only QREF files, there are operators who will require full SOI information. Special Operator Task 2 Alternate is a variation of Task 2, allowing transfer of complete SOI files. Dissemination within the unit is still accomplished by transferring SOI information for one ANCD to another. When this special task is not performed by communications specialists or designated NCOs, operators who need the full SOI information file must be trained to perform this task.

**DETAILED FLOWCHART**

SUBTASKS	ACTIONS	RESULTS
<p><b>a. Prepare Source ANCD for full SOI transfer</b></p>	(1) Turn ANCD ON	select: <b>Soi</b> Radio supervisor
	(2) Enter SOI	qRef Group Net sufX Pyro Tmpd <b>Set</b> C/s Find Memo
	(3) Enter SET	select: Choose <b>Send</b> Receive
	(4) Enter SEND	Scroll ( /-) and press ENTR to select Set [↓]
	(5) Press down arrow and scroll to set desired	Set: (name/nr) Edn: (name)/(tp) <b>[ENTR]</b>
	(6) Press ENTR to select	* Do you want to transfer QREF? (Y/N)
	(7) Respond NO	* Do you want to specify groups to send? (Y/N)
	(8) Respond NO	* Do you want to specify a time pd to send? (Y/N)
	(9) Respond NO	* Include Suffix & Smoke/Pyro data? (Y/N)
	(10) Respond YES	send to: <b>Ancd</b> Pc Broadcast Stu
	(11) Enter ANCD	Connect ANCD to ANCD [↓]

SUBTASKS	ACTIONS	RESULTS
	(12) Connect ANCDs and press down arrow	Press [SEND] to send <b>(WAIT)***</b>
b. Prepare Target ANCD to full SOI transfer	(1) Turn ANCD ON	select: <b>Soi</b> Radio sUpervisor
	(2) Enter SOI	qRef Group Net sufX Pyro Tmpd <b>Set</b> C/s Find Memo
	(3) Enter SET	select: Choose Send <b>Receive</b>
	(4) Enter RECEIVE	receive from: <b>Ancd</b> Pc Broadcast Stu
	(5) Enter ANCD	Connect ANCD to ANCD [↓]
	(6) Press down arrow	Press [RCV] to receive <b>(WAIT)***</b>
c. Transfer full SOI from ANCD to ANCD	(1) Press [SEND] on Source ANCD	Processing. Please wait. (shows % of bytes sent)
		Sending of SOI data is completed
	(2) Press [RCV] on Target ANCD	Processing. Please wait. (shows number of bytes sent)
		Receive operation was successful

\* These screens appear only when related data is stored in the ANCD.

\*\* You must respond NO; you can transfer either a FULL or QREF SOI, but not at the same time.

\*\*\* **Do not** press [SEND] on Source ANCD until you are ready to press [RCV] on Target ANCD; then press [RCV] within about 20 seconds of pressing [SEND].



**5.5f. Perform Cold Start Net Opening (Special Operator Task 3)**

**DESCRIPTION**

Operators will be required to perform this special task only if the NCS elects to use the Cold Start net opening procedure. Hot Start is the more commonly used net opening procedure. Cold Start procedures require operators to load their radios with COMSEC keys and FH data, stand by at the prescribed time, communicate with the NCS on the MAN channel, set RT FCTN to LD, note when ERF is received, and press STO and channel number to retain data. Any failure in the ERF process prevents the operator concerned from communicating in the frequency hopping mode. Because the Cold Start procedure is more demanding in coordination and operator requirements, units normally use the Hot Start procedure.

**DETAILED FLOWCHART**

SUBTASKS	ACTIONS	RESULTS
<p><b>a. Prepare radio to receive an ERF</b></p>	<p>(1) Load MAN (SC) frequency into RT</p>	<p>(See Primary Operator Task 1)</p>
	<p>(2) Load RT with required COMSEC/FH data</p>	<p>(See Primary Operator Task 2)</p>
	<p>(3) Set FCTN to LD</p>	<p>N/A</p>
	<p>(4) Set COMSEC to CT*</p>	<p>N/A</p>
	<p>(5) Set CHAN to MAN</p>	<p>Display shows "COLD" (ready to receive an ERF)</p>
	<p>(6) Set MODE to FH</p>	<p>N/A</p>
<p><b>b. Receive and store ERF</b></p>	<p>(1) Standby until NCS sends the ERF</p>	<p>N/A</p>
	<p>(2) Note signal display activate</p>	<p>Display shows "HF XXX"</p>
	<p>(3) Press STO</p>	<p>Display shows "STO _"</p>
	<p>(4) Press X (1-6)</p>	<p>Display shows channel entered</p>

SUBTASKS	ACTIONS	RESULTS
<b>c. Make communications check</b>	(1) Set CHAN to X (1-6)	(Channel where ERF was stored)
	(2) Set FCTN to SQ ON	N/A
	(3) Call NCS (or respond to NCS call)**	Cold Start net opening is completed

\* *The net may be opening in PT if communication security is not a consideration, but use of CT for net opening is recommended as the best course of action.*

\*\* *If you are unable to contact your NCS, or the NCS fails to contact you, switch back to the MAN channel and standby for the NCS to contact you on that channel.*

**5.5g. Receive Net Update ERF from NCS (Special Operator Task 4)**

**DESCRIPTION**

This task is performed when there is a requirement to change, or update, some element of FH data, and the operational situation makes it impossible or impractical to disseminate the new data by physical connection of ANCD to ANCD. In such cases, the NCS alerts net operators that they are to receive a net update ERF. Operators then change the RT FCTN from SQ ON to LD, remaining on the operational channel. The NCS sends the ERF on the operational channel (not on MAN as during a Cold Start net opening). Once the net update ERF has been sent, the new data may be made effective immediately or stored for later implementation. ERF, Broadcast, and OTAR constitute the means by which FH data, SOI information, and COMSEC key (TEK only) can be transferred electronically from one location to another.

**DETAILED FLOWCHART**

<b>SUBTASKS</b>	<b>ACTIONS</b>	<b>RESULTS</b>
<b>a. Prepare to receive net update ERF</b>	(1) Stay on the operational channel	N/A
	(2) Set FCTN to LD	N/A
<b>b. Receive and store net update ERF</b>	(1) Standby for NCS to send net update ERF	N/A
	(2) Note signal display activate	Display shows " HF XXX"
	(3) Press STO	Display shows " STO _"
	(4) Enter X (1-6)*	Display shows " STO X: and blinks

SUBTASKS	ACTIONS	RESULTS
<b>c. Make communications check</b>	(1) Set CHAN to X (1-6)	(Channel in which ERF was stored)
	(2) Set FCTN to SQ ON	N/A
	(3) Call NCS, or respond to NCS call	Net update ERF is completed**

\* The NCS will direct which channel is to be used for storing the net update ERF: If the update is effective immediately, the ERF will be stored in the operational channel. If the update is to be made effective at a later time, a channel other than the operational channel will be used for storage of the ERF update data.

\*\* It is assumed that the operator has the same COMSEC key (TEK) loaded in all operational channels of the radio. Otherwise, the operator would have to scroll the proper TEK to the new operational channel to have secure communications.

**5.5h. Perform CUE and ERF Late Net Entry (Special Operator Task 5)**

**DESCRIPTION**

This task may be required when a radio has been out of the net for some period. or has lost its sync time. The preferred action is to try Passive Late Net Entry first (See Primary Operator Task 4). This method requires the operator to load CUE and MAN frequencies, “cue” the NCS in PT, repeat the “cue” until a response is received, switch COMSEC to CT to receive the NCS response, use single channel mode, and receive and store an ERF when it is sent. (A simpler method of re-entering the net when the passive method does not work is the Hot Start procedure (See Primary Operator Task 3.)

**DETAILED FLOWCHART**

<b>SUBTASKS</b>	<b>ACTIONS</b>	<b>RESULTS</b>
<b>a. Prepare radio to perform CUE and ERF method</b>	(1) Load CUE and MAN freqs into RT	(See Primary Operator Task 1)
	(2) Set CHAN to CUE and COMSEC to PT	(CUE signal goes through only when RT is set to PT)
<b>b. CUE the NCS</b>	(1) Press PTT for 4 or 5 seconds	(There is no need to speak)
	(2) Set COMSEC to CT at once*	(NCS/Alt NCS will respond in CT on CUE frequency)
	(3) Wait for NCS to respond	(CUE signal goes through only when the net is quiet)
	(4) Repeat every 15 seconds until NCS responds	(You have no way of knowing if net is busy or quiet)
<b>c. Obtain ERF</b>	(1) When NCS responds, request an ERF	(Responding NCS will direct you to the MAN channel)
	(2) Receive and store ERF when sent by NCS	(See Special Operator Task 3 for detailed procedure)
	(3) Re-enter the net	CUE and ERF late net entry is completed

**5.5i. Conduct Retransmission (RXMT) Operations (Special Operator Task 6)**

**DESCRIPTION**

This special operator task may be required whenever communications with a net station is lost, or at risk of being lost, due to distance or physical obstacles such as hills and mountains. Communications specialists, scouts, staff drivers, and other operators having dual radio configurations should be trained to perform this task whenever it is required. The task involves communications between the requesting NCS and the RXMT site, and between the RXMT site and the distant station. It requires the use of two net IDs, or two SC frequencies, and physical connection of the two RXMT radios by special retransmission cable. Radio and frequency designations are as shown in the RXMT graphic (See Figure 5-21).

**DETAILED FLOWCHART**

SUBTASKS	ACTIONS	RESULTS
<p><b>a. Prepare to perform RXMT mission</b></p>	<p>(1) Obtain required SC/FH data for RXMT operation*</p>	<p>(Available in ANCD for from unit SOP)</p>
	<p>(2) Load RT-C and RT-D with SC/FH data for mission</p>	<p>(RT-C and RT-D require different SC freq/Net IDs)</p>
	<p>(3) Move to RXMT site</p>	<p>(LOS communications with RT-A and RT-B are desirable)</p>
<p><b>b. Establish comm from RXMT site</b></p>	<p>(1) Call NCS on F1 using RT-C</p>	<p>(F1 may be net operational channel or RXMT special)</p>
	<p>(2) Contact distant station (RT-B) using RT-D**</p>	<p>(Relocation of RXMT site may be required to contact RT-B)</p>
	<p>(3) Provide ERF to RT-B if required</p>	<p>(Distant station may require FH data/sync time)</p>
	<p>(4) Contact RT-B on F2 using RT-D</p>	<p>(Contact between RT-B and RT-D on F2 is essential)</p>
<p><b>c. Initiate RT-A to RT-B RXMT communications</b></p>	<p>(1) Install RXMT cable between RT-C and RT-D</p>	<p>N/A</p>
	<p>(2) Set RT-C and RT-D FCTN switches to RXMT</p>	<p>N/A</p>
	<p>(3) Set RT-C MODE to FH</p>	<p>(RT-A continues to be the NCS on F1 linkage)</p>

SUBTASKS	ACTIONS	RESULTS
	(4) Set RT-D MODE to FH-M	(RT-D serves as NCS on F2; ensure RT-B is in FH)
	(5) Set RT-C and RT-D COMSEC to CT/PT****	(See **** below for COMSEC switch requirements)
	(6) Request RT-A (NCS) call RT-B using RXMT setup	RXMT mission is now being performed*****

*RXMT MODE: When ASIP radios are used at the RXMT site and are temporarily taken out of the RXMT mode, the RXMT cable must be disconnected until the radios are placed back into a RXMT mode.*

\* *RXMT may be performed as FH to FH, SC to SC, or mixed FH to SC. FH to SC mode is particularly effective when communications between a SINGARS net and a VRC Series-12, or similar SC net, are required.*

\*\* *The use of two OE-254 antennas, separated as widely as feasible, may be required in order to achieve line-of-sight communications.*

\*\*\* *See Special Operator Task 7 for the procedure regarding sending an ERF*

\*\*\*\* *RT-1523 version of the SINGARS radio requires that COMSEC switches of RXMT radios be set to PT for SC-SC and FH-SC communications. (Only the "SC" RT must be in PT.) If the net is operating in CT, the RXMT operators can monitor only the FH portion of the traffic.*

\*\*\*\*\* *In RXMT mode, RT-C and RT-D provide half-duplex communication. A handset or speaker must be connected to both RXMT radios for both sides of a communication to be heard by RXMT operators.*

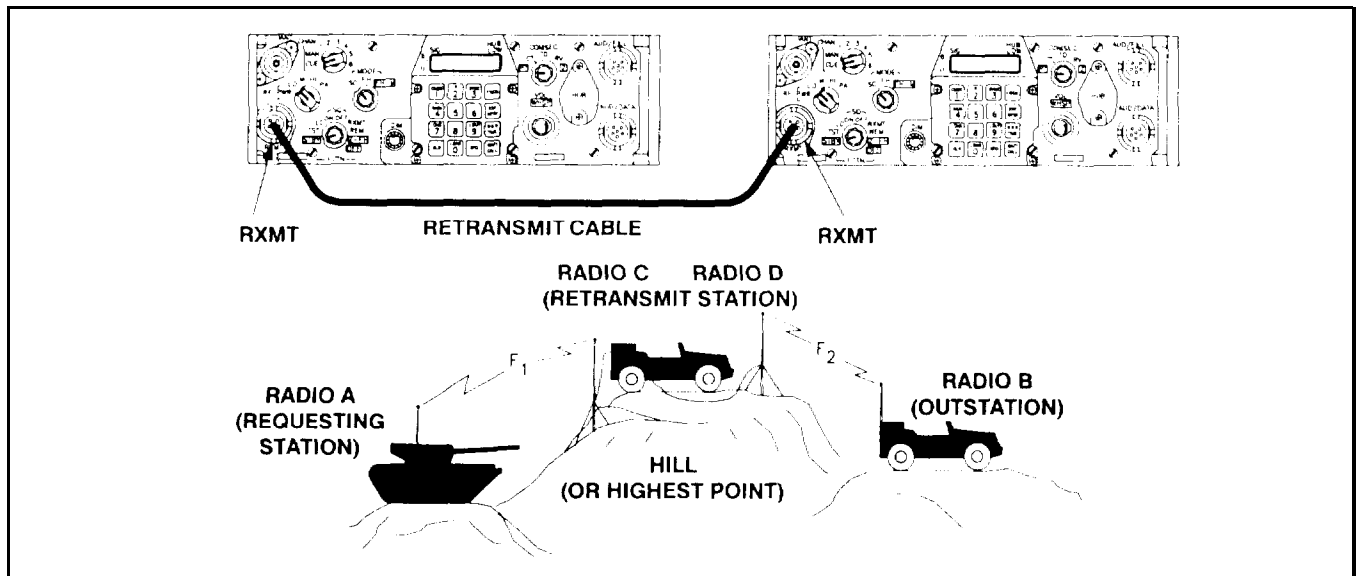

Figure 5-21. RXMT Operation

**5.5j. Send an ERF as Part of RXMT Operation (Special Operator Task 7)**

**DESCRIPTION**

This is not a normal operator task. It is performed only as part of an RXMT operation. When operators are required to perform RXMT operations, it may be necessary for them to send an ERF to the distant station in order to establish FH communications. Sending an ERF requires the sending operator to change from FH to FH-M, with associated risk to net sync time if the operator fails to return to FH immediately after sending the ERF. The ERF procedure is known by all NCS personnel, thus the RXMT operator should be able to obtain verbal help if needed.

**DETAILED FLOWCHART**

SUBTASKS	ACTIONS	RESULTS
a. Obtain data to be sent by ERF	If not already loaded, load ERF data in RT-D*	(If net ID only, see Special Operator Task 8 for details)
b. Contact distant station	Alert RT-B RXMT data is being sent by ERF	(ERF is sent on operational channel used for the alert)
c. Prepare RT to send ERF	(1) Set FCTN to LD	N/A
	(2) Set MODE to FH-M**	N/A
d. Send ERF	(1) Press [LOAD] on RT keypad	Display shows "HLD _"
	(2) Enter channel where data is stored	Display shows "HF XXX"
	(3) Press [ERF] on RT keypad	Display shows "SEND"
e. Make communications check	(1) Wait for distant station (RT-B) to store the ERF	(20-30 seconds should be adequate)
	(2) Call RT-B and confirm that ERF was received	(Obtain ACK from all operators who were to receive the ERF)



SUBTASKS	ACTIONS	RESULTS
f. <b>Resume normal communications</b>	(1) Change MODE from FH-M to FH	(Important to get out of FH-M after sending the ERF)**
	(2) Set FCTN to SQ ON	<b>N/A</b>
	(3) Continue FH, CT communications	(Task of send an ERF is complete)***

\* Any radio may be used, but in preparing for an RXMT mission, use of RT-D is recommended.

\*\* Use of RT-D on F2 (See Figure 5-21) minimizes the possibility of interfering with net sync time. Once RXMT operations begin, RT-D must be set to FH-M as shown in Special Operator Task 6. The best rule to follow is do not transmit in the FH-M position except to send an ERF and for RT-D during RXMT operations.

\*\*\* If common TEK, FH data, and sync time are being used, an alternate procedure is for RXMT operator to contact RT-B on a secure FH channel and request RT-B operator to change to a specified net ID for purpose of RXMT operation.

**5.5k. Change Net ID (Special Operator Task 8)**

**DESCRIPTION**

This Special Operator Task is performed when there is a requirement to communicate with a net, or station, which is not a part of the operational loadset, or loadsets if more than one radio is being used. Commanders, staff officers, drivers, and others who frequently move about the battlefield should be able to perform this task without assistance other than reference to the Operator's Pocket Guide. As noted below, the RT-1523 version of the SINCGARS radio requires use of the FH-M position in order to change a net ID, and will allow the operator to change only the last two digits of the net ID. Despite these differences, the procedure for changing a net ID is essentially the same. Use of this procedure enable the operator to contact virtually any SINCGARS station within a division.

**DETAILED FLOWCHART**

SUBTASKS	ACTIONS	RESULTS
<b>a. Prepare radio for net ID change</b>	(1) Set MODE to FH-M* (RT-1523 only)	<b>(Do not transmit while in the FH-M position.)</b>
	(2) Set FCTN to LD	<b>N/A</b>
	(3) Set CHAN to 1-6	(To channel where net ID to be changed in now stored)
<b>b. Enter new net ID in RT</b>	(1) Press [FREQ]	Display shows " F XXX"
	(2) Press [CLR]	Display shows " F _ _ _"
	(3) Enter new net ID (3 digits)**	Display shows " F XXX"
	(4) Press [STO]	Display blinks; new net ID is now stored

SUBTASKS	ACTIONS	RESULTS
c. Resume normal communications	(1) Return MODE to FH (if set to FH-M)	N/A
	(2) Set FCTN to SQ ON	N/A
	(3) Set CHAN to 1-6 as desired	(New net ID is now ready for use)

\* The RT-1523 version of the SINGARS radio requires the MODE switch to be set to the FH-M position in order to change the net ID of any channel. Skip this step unless it is required. If you have to switch to FH-M, be sure to return to FH as soon as the procedure for changing net ID is completed.

\*\* The RT-1523 version of the SINGARS radio will allow you to change only the last two digits of the net ID. Otherwise, the procedure for changing net IDs is the same.

**5.6. SPECIAL OPERATOR TASKS (SIP/ASIP)**

**GENERAL**

In addition to the eight special operator tasks, there are two Special SIP/ASIP Operator Tasks. These special SIP/ASIP related tasks use the SIP/ASIP RT as an RCU; and send data from one computer to another over a SINCGARS secure, frequency hopping net using RS-232 enhanced data feature.

**5.6a. Use SIP/ASIP RT as an RCU (Special Operator Task 9)**

STEP	ACTION	RESULT
1	Ensure SIP/ASIP RT and RCU(RT) are loaded	Prepares SIP/ASIP RT and RCU(RT) for remote operations*
2	install two-wire kink from RCU(RT)** to remoted radio	N/A
3	Set remoted radio FCTN switch to the REM position	This enables the RCU(RT) to control the remoted radio
4	Set RCU(RT) FCTN switch to SQ ON	(NOTE: FCTN positions LD, SQ OFF, and RXMT may also be used)
5	Set RCU(RT) DATA to any position	N/A
6	Press "RCU" key on RCU(RT); and select the RCU option	"LD", "LDE", "RT", "RCU", and "EXT" options appear in the display (For ASIP, "EXT" is not shown.)
7	Wait for 7 seconds; then note when RCU(RT) display blinks	The SIP/ASIP RT is now ready to perform as an RCU(RT)
8	Set RCU(RT) FCTN switch to the REM positron***	This enables the RCU(RT) operator to call the REM radio operator by wire
9	Press RCU(RT) CALL key and PTT at same time for 4-7 seconds	Producing ring tone and CALL message at REM RT; operators can now talk via orderwire (not secure)
10	Set RCU(RT) to SQ ON	REM radio is now controlled by the RCU(RT)

\* For use of a SIP RT as either a manpack RCU or a manpack remoted radio, Battery Box CY-8523A/B is required. Battery Box CY-8523C cannot be used for manpack remote operations, ASIP RT requires a two-wire adapter.

\*\* The Control, Receiver-Transmitter (RCU), C-11561, may continue to be used for remote control of a SINCGARS SIP radio when used for voice and SINCGARS data modes. It cannot be used for enhanced data modes.

\*\*\* RCU(RT) COMSEC must be set to PT to talk on orderwire.

**5.6b. Send Data Via RS-232 Mode (Special Operator Task 10)**

STEP	ACTION	RESULT
1	Ensure computer has required commercial communication program loaded*	SIP/ASIP radio will except any program offering "Xmodem", a widely used file transfer protocol
2	Connect cable from computer to AUD/DATA connector on the SIP/ASIP RT	This data method does not require SIP/ASIP VAA functions
3	By voice, alert receiving station that data message is to be sent via RS-232	Also, coordinate data rate to be used if not designated by comm program or unit SOP**
4	Select EDM rate to be used for RS-232 transmission	See*** below for steps required to select EDM data rate
5	Using computer, prepare data message to be sent, or load your computer with data	N/A
6	Check net to ensure that traffic is not heard or noted by signal display	Need clear net to ensure that data message goes through****
7	Follow communication program procedures to send and receive data messages	Control is from computer: SIP/ASIP radio serves as data communications carrier

\* Both sending and receiving stations must use the same or compatible "Xmodem" communication program.

\*\* Any one of the four enhanced data rates are used for RS-232 traffic: 1200N, 2400N, 4800N, and 9600N (BPS). Selection is based primarily upon the distance between stations. For shorter ranges, fast rates work well. For longer ranges, slower data rates perform better. If data is sent through an RXMT site, RXMT radios must be set to the same EDM data rate as the outstations

\*\*\* Select data rate using PC data transfer software (i.e. Procomm), connect PC to RT via data cable. Select "RS-232" on RT; press ENTER on PC; PC should indicate the RT connected at xxxx, the PC rate you selected. If a problem is encountered repeat above steps.

\*\*\*\* If voice mode has priority of use in your net, it may be necessary to wait for a quiet period to send data messages. (Pressing PTT will not interrupt data traffic. Doing so merely stops the receipt of traffic at your radio).

**5.7. OTHER OPERATOR PROCEDURES**

**5.7a. Battery Life Condition Indicator**

**MANPACK RADIOS**

Manpack and dismount radios are battery powered. A “Battery Life Indicator” built into the SINCGARS RT will give you an estimate of battery usage which you must convert into an estimate of remaining battery life.

**DURING ASSEMBLY**

During radio assembly, note if the main power battery is new or used. If it is used, note the number written on the side of the battery.

**IF USED BATTERY**

If battery IS used, upon completion of radio assembly, load battery life indicator (number on side of battery). No action required if battery is new.

- Set FCTN to LD, press BATT, note 00 in display, press CLR, enter battery life indicator number, and press STO.
- Battery life Indicator of used battery has now been entered into the RT
- During radio operation, you can determine an estimated status of main battery power by following these steps.
- With FCTN at SQ ON, press BATT and read battery life indicator.
- A reading of 11 or higher may mean that your main battery is nearing exhaustion. (This reading is at best a estimate based on usage computations by the RT.)

**IN COMBAT**

During combat and operational missions, you may want to replace the main battery when the battery life indicator reads 11 or higher for RT-1523/A/B/C/D (See Figure 5-23), or 1/8 for RT-1523E, or you may wait until your battery is exhausted before changing it. (One indicator of a weak manpack radio battery is a signal strength display reading of 3 or less when you PTT with RF PWR set to HI.)

**FOR TRAINING**

For training, continue to use your main power battery until it is exhausted. (This is to save batteries and money.)

**RECORDING USAGE**

Upon completing a mission, when the main battery is to be removed, note and record battery life on the side of the battery. **The Battery Life Indicator must be read before FCTN is set to OFF, or battery life data will be lost.**

**HUB ROLE**

In combat or training, remember that with a good HUB battery installed, your RT will retain all stored data while you replace the main battery. The ASIP RT does not have a HUB battery, it contains circuitry that retains fill for 15 minutes after main power is lost (either turning off vehicular power or changing battery). A HUB inser has been designed for vehicular applications that will accommodate a BA-5372 or AA batteries. The insert will insure that fill will be retained during periods that vehicular power is turned off (listening silence or other mission requirements).

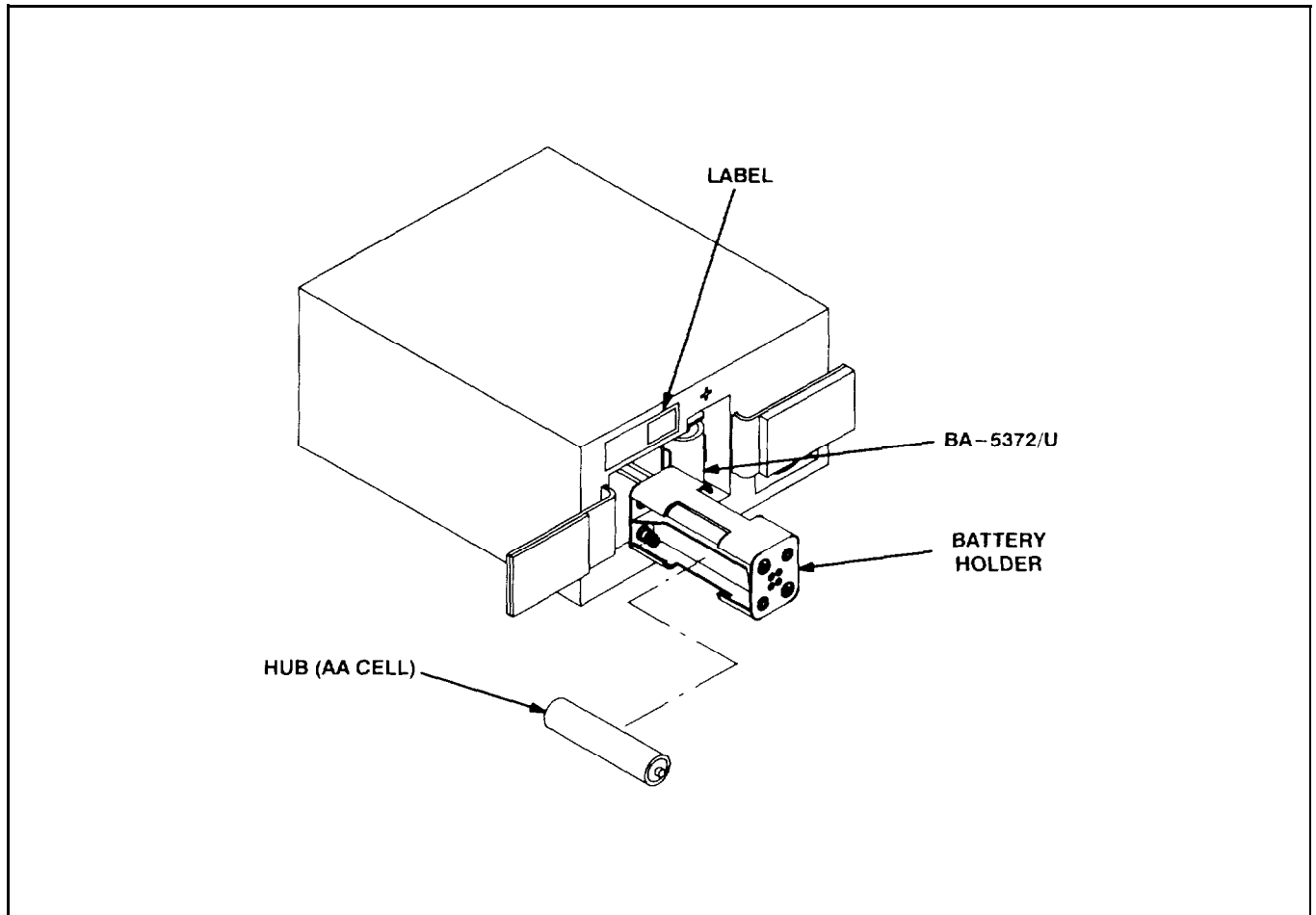

**Figure 5-22. HUB Insert**

**WORST CASE**

Remember also that in the absolute worst case where you lose main power and your HUB is dead, all you have to do is perform an ICOM fill, including sync time, using your ANCD

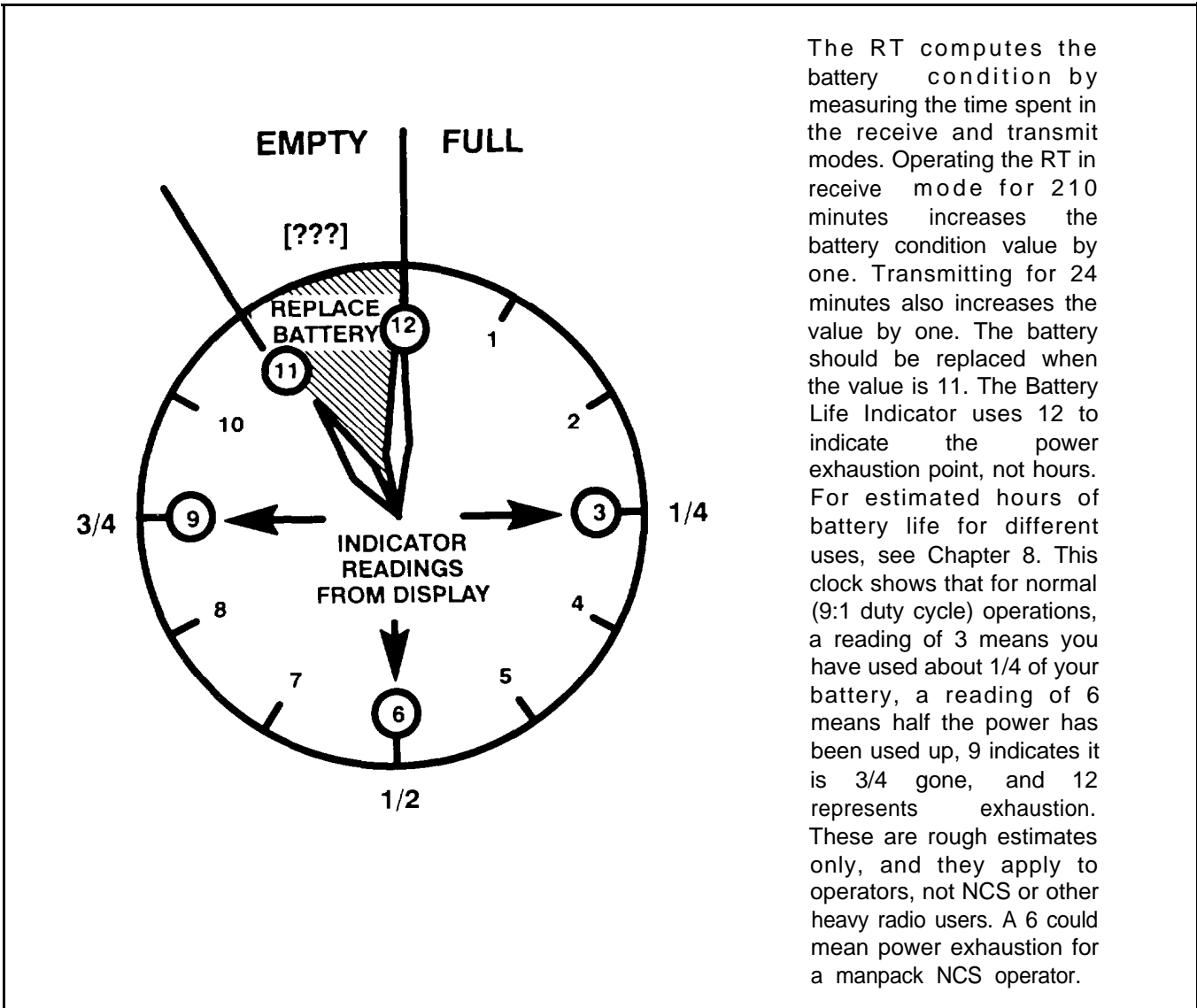

The RT computes the battery condition by measuring the time spent in the receive and transmit modes. Operating the RT in receive mode for 210 minutes increases the battery condition value by one. Transmitting for 24 minutes also increases the value by one. The battery should be replaced when the value is 11. The Battery Life Indicator uses 12 to indicate the power exhaustion point, not hours. For estimated hours of battery life for different uses, see Chapter 8. This clock shows that for normal (9:1 duty cycle) operations, a reading of 3 means you have used about 1/4 of your battery, a reading of 6 means half the power has been used up, 9 indicates it is 3/4 gone, and 12 represents exhaustion. These are rough estimates only, and they apply to operators, not NCS or other heavy radio users. A 6 could mean power exhaustion for a manpack NCS operator.

Figure 5-23. Battery Life Indicator Chart



### 5.7b. Loading and Clearing Offset Frequencies

<b>DEFINITION</b>	The SINCGARS radio allows single channel frequencies to be offset by plus or minus 5 or 10 KHz. When operating in the single channel mode, this capability can be employed to help work through jamming or other interferences.
<b>LOADING PROCEDURE</b>	Use the following procedure to load an offset frequency. <ul style="list-style-type: none"> <li>• Load regular SC frequency (Primary Operator Task 1).</li> <li>• Set FCTN to SQ ON and CHAN to one to be offset</li> <li>• Press FREQ, then OFST, then CHG until desired offset is shown in RT display.</li> </ul>
<b>CLEARING PROCEDURE</b>	Use the following procedure to clear an offset frequency <ul style="list-style-type: none"> <li>• Set FCTN to SQ ON and CHAN to one to be cleared.</li> <li>• Press FREQ, then OFST then CHG until RT display shows "00."</li> </ul>

### 5.7c. Scrolling COMSEC Keys

<b>DEFINITION</b>	The SINCGARS radio allows you to move COMSEC keys about in channels 1 through 5, in both SC and FH modes of communication. This movement is called scrolling.
<b>USE OF LOADSETS</b>	With normal use of loadsets which align channels and COMSEC keys according to unit needs, there is limited requirement to scroll TEKs.
<b>EXAMPLE OF NEED</b>	When you change net ID to contact a station in a division other than your own, you will normally need to use that division's TEK.
<b>EXAMPLE OF USE</b>	You anticipated this need and loaded the additional TEK in your channel 5, the least used net of the loadset. To contact the other division, you change the net ID in channel 2, and scroll TEK 5 to CHAN 2.
<b>SCROLL PROCEDURE</b>	Use the following procedure to scroll TEK from one channel to another (1-5 only; KEK cannot be moved out of channel 6.) <ul style="list-style-type: none"> <li>• Set CHAN to the channel to be used.</li> <li>• Press CMSC (RT display shows current TEK).</li> <li>• Press CHG until desired TEK appears.</li> <li>• If COMSEC alarm is heard, press PTT twice to clear it.</li> <li>• Changing CHAN switch to another channel automatically returns TEKs to their original position.</li> </ul>

### 5.7d. Scanning Capability

#### DEFINITION

The SINCGARS radio has the ability to scan up to eight single channel frequencies ( CUE, MAN, and CHAN 1-6). When a signal is found, the RT will lock in on that channel, and the RT display show the number of that channel. As an operator, you can both receive and transmit on the locked channel. When the channel has been inactive for 2.5 seconds, the RT will automatically resume scanning.

#### TO START SCANNING

To start scanning, follow this procedure

- Set CHAN to CUE, FCTN to SQ ON, MODE to FH, and COMSEC to CT or PT as desired.
- Press STO; RT display will show " SCAN \_".
- Enter the number 8 to scan all channels at the same priority. Enter the number 0 thru 7 to establish priority for that channel. The priority channel will be scanned more often than other channels. RT display will show the number you entered, and scanning will begin.
- To resume scanning while a channel is locked in, press FREQ.

#### TO TRANSMIT

To transmit on a locked in channel, press PTT within 2.5 seconds after net clears (or scanning will automatically resume).

To select a channel to transmit on, use RT keypad to enter desired channel number, and channel selected will appear in the RT display.. Press PTT within 2.5 seconds of channel number appearing in display.

To transmit on the priority channel you selected, merely press PTT, and RT display will show " CH X" , and you are ready to transmit.

#### TO CHECK FREQUENCY

To determine the frequency of a locked in channel, press STO, and frequency will be shown in RT display.

#### TO CANCEL CHANNEL

To delete a channel from the scan sequence, enter the channel number using the keypad, and press CLR. Scanning will resume less the deleted channel.

#### TO RESTORE CHANNEL

To restore a deleted channel, enter channel number using the RT keypad, display will show CH X, and restored channel will be included in scanning sequence.

#### TO STOP SCANNING

To stop scanning, merely set CHAN from CUE to another position.

**5.7e. Jamming and Anti-Jamming Actions**

**DEFINITION**

Jamming is the intentional transmission of signals that interrupt your ability to transmit and receive. Interference is the accidental disruption of communications by friendly sources. For practical purposes, the following coverage of jamming includes both situations. Anti-jamming includes any corrective action taken by the operator to work through intentional jamming and accidental interference.

**IDENTIFICATION**

If you are being jammed, you may hear strong static, strange noises, random noise, or no noise or signals at all. If you suspect you are being jammed, look for one of the specific symptoms shown in the table below.

**SC OPERATIONS**

Jamming/anti-jamming procedures for SC mode of operations are as shown in the chart below.

**JAMMING/ANTI-JAMMING PROCEDURES; SC MODE OF OPERATIONS**

SYMPTOM	POSSIBILITIES	ACTIONS
<p>You hear no traffic, and you are not transmitting. SIG display is lit and shows a signal higher than LO.</p>	<p>Your handset could be stuck, producing a “hot mike” situation.</p>	<p>Press PTT several times to free up mike. If necessary, replace handset with known good one.</p>
	<p>You are being jammed. In SQ OFF, you hear strong static or random noise. When antenna is disconnected, SIG display drops and noise disappears or is reduced.</p>	<p>If feasible, try to place an obstacle between you and the enemy. Notify your supervisor and, if appropriate, prepare a MIJI feeder report.</p>
	<p>Your RT is faulty or locked up. With handset and antenna disconnected, your SIG display remains lit and above LO.</p>	<p>Set RT FCTN to STBY position and then back to SQ ON. If problem continues, contact your unit maintenance.</p>
<p>You hear random radio traffic. Your SIG display is lit and shows a signal higher than LO.</p>	<p>You are experiencing friendly or enemy radio interference.</p>	<p>Set RT FCTN to SQ OFF and try to communicate. Change to a longer range antenna. If feasible, try to place an obstacle between you and the source of interference. Advise NCS of your problem.</p>
<p>You may or may not hear any noise SIG display goes on and off at regular intervals or in random order.</p>	<p>You are probably experiencing enemy sweep jamming.</p>	<p>Set RT FCTN to SQ OFF, and you hear noise or static each time the SIG display lights. If feasible, try to place an obstacle between you and the enemy. Advise NCS of your problem</p>

**FH OPERATIONS**

Jamming/anti-jamming procedures for FH operations are shown in the chart below.

**JAMMING/ANTI-JAMMING PROCEDURES; FH MODE OF OPERATIONS**

<b>SYMPTOM</b>	<b>POSSIBILITIES</b>	<b>ACTIONS</b>
<p>You hear loud noise or strong static making net traffic difficult to impossible to hear. Your SIG display remains on or goes on and off at regular intervals. Signal strength is greater than LO.</p>	<p>You are being jammed if disconnecting the antenna causes the SIG display to drop to LO and noise level is reduced.</p>	<p>If feasible, try to place an obstacle between you and the enemy. Advise NCS of your problem.</p>
	<p>You may be experiencing interference from a friendly communication system (called a co-site problem).</p>	<p>Try to get interfering system shut down momentarily to determine if it is the source of your problem. If it is, change your location, remote your antenna or RT or try to place an obstacle between you and the interfering station.</p>
<p>You hear a constant hiss or background noise in the handset but no loud noise or net traffic.</p>	<p>There is a captured RT in your net, constantly transmitting to act as a jammer.</p>	<p>Press your PTT two times. Net should clear. Advise NCS of your action.</p>
	<p>There is a stuck mike or bad handset in you net that is locked in the PTT position.</p>	<p>Press your PTT two times. Net should clear. Advise NCS of your action.</p>
	<p>Your own handset is stuck if you hear sidetone without pressing PTT SIG display drops to LO or below when handset is disconnected.</p>	<p>Free up PTT or replace handset with a known good one.</p>
<p>You hear background popping or static when receiving, and your operating range is reduced. Your SIG display is flickering.</p>	<p>You are probably experiencing co-site interference from a friendly radio.</p>	<p>Identify interfering radio and request operator to reduce RF PWR setting, move your radio at least 50 meters, or remote your RT or antenna. Advise NCS of your action.</p>

## CHAPTER 6

### NET CONTROL STATION (NCS) TASKS

**IN THIS CHAPTER:**

<b>6.1</b>	<b>GENERAL</b> .....	<b>6-2</b>
<b>6.2</b>	<b>NCS RESPONSIBILITIES</b> .....	<b>6-3</b>
<b>6.3</b>	<b>PRIMARY NCS TASKS</b> .....	<b>6-6</b>
a.	Definition of Primary NCS Tasks .....	6-6
b.	Summary of Primary NCS Tasks .....	6-6
c.	Transfer Partial COMSEC/FH Data, ANCD to ANCD (Primary NCS Task 1) .....	6-7
d.	Transfer COMSEC Key from ANCD to RT (NCS Option 1A) .....	6-9
e.	Designate New Default Loadset (NCS Option 1B) .....	6-10
f.	Change Eset in One Channel (NCS Option 1C) .....	6-11
g.	Transfer Selected SOI Information, ANCD to ANCD (Primary NCS Task 2) .....	6-12
h.	Conduct Hot Start Net Opening (Primary NCS Task 3) .....	6-14
i.	Conduct Cold Start Net Opening (Primary NCS Task 4) .....	6-15
j.	Respond to CUE Calls (Primary NCS Task 5) .....	6-17
<b>6.4</b>	<b>SPECIAL NCS TASKS</b> .....	<b>6-18</b>
a.	Definition of Special NCS Tasks .....	6-18
b.	Summary of Special NCS Tasks .....	6-18
c.	Transmit Updated FH Data via Net Update ERF (Special NCS Task 1) .....	6-19
d.	Transmit SOI Information Using Broadcast Mode (Special NCS Task 2) .....	6-21
e.	Send TEK to Other NCSs Using MK Method of OTAR (Special NCS Task 3) .....	6-24
f.	Send TEK to Net Operators Using AK Method of OTAR (Special NCS Task 4) .....	6-26
g.	Receive and Store TEK Sent by MK Method of OTAR (Special NCS Task 5) .....	6-29

<b>6.1. GENERAL</b>
---------------------

**CONTROL**

The SINCGARS radio employs keys and variables to provide secure, frequency hopping communications. The big advantage is that the enemy cannot read your traffic, cannot locate your position through direction finding, and has great difficulty in trying to jam your communications. Control is the price to be paid for these advantages. Each radio in a net must have the same COMSEC keys, FH data, and sync time in order to communicate. It is the Net Control Station that provides the required degree of control.

**TASK DIVISION**

NCS tasks are divided into two groups: primary and special. Primary tasks are those that NCS personnel may be called upon to perform at any time. The second category, special, includes tasks that may or may not be performed depending upon command policy, tactical situation, and state of training.

**TRAINING MATERIALS**

As with the job of the SINCGARS operator, the job of the NCS has also been simplified by the statement of task procedures in clear, easy to follow, steps. And, like the operator, the NCS is provided a small pocket guide containing abbreviated task procedures for all operator requirements, plus primary NCS tasks. This pocket guide serves as a memory jogger for the trained NCS operator, precluding any need to memorize any aspect of SINCGARS radio operation.

**6.2. NCS RESPONSIBILITIES****NET OPENING**

It is the NCS who is responsible for opening the secure, frequency hopping SINCGARS net. Net opening time is announced in advance to enable operators to make proper preparations. The NCS ensures that the net is up and fully operational in time to support unit mission communications requirements.

**ANCD**

As the principal supervisor of the net, the NCS ensures that all net operators have ready access to a fully loaded ANCD containing the prescribed COMSEC keys, FH data (hopset, TSK, and net IDS, and GPS-based sync time to support net opening preparations.

**ASSEMBLY**

NCS personnel are expected to properly assemble their own manpack radios and install their own required vehicular radio components in preparation for net opening. This includes connecting cables, antennas, handsets, loudspeakers, and any other components that are to be used.

**CAUTION****YOUR RT CAN BE DAMAGED BY****IMPROPER ATTACHMENT OF MANPACK ANTENNAS**

1. To avoid damage, turn the sleeve only, not the antenna.
2. Turning the antenna can destroy the antenna connector in the RT

**PMCS**

In that NCS personnel are also operators, they are required to perform Before Operation Preventive Maintenance Checks and Services (PMCS), as shown in Chapter 8. Performing PMCS involves checks of controls, cables, antennas, power source, self-test, keypad, data loading, and ability to communicate. By performing PMCS, NCS personnel are assured that all components of their radios are working properly, or that something needs to be fixed, by the NCS operator or unit maintenance. The PMCS charts found in Chapter 8 should be followed exactly in the performance of PMCS. No NCS operator action will pay greater dividends.

**LOADING RT**

When they are satisfied with the results of Before Operation PMCS actions, NCS personnel load their own radios with data and sync time, in preparation for net opening. The first three Primary Operator Tasks provide detailed procedures.

**NET DISCIPLINE**

It falls to the NCS to maintain net discipline. This responsibility includes controlling access to the net, maintaining an informal record of which stations are in the net, and ensuring that messages are as brief as possible and use proper language.

**SYNC TIME**

In that it is the NCS radio, set to the FH-M mode position, that automatically keeps all of the net radios within the plus or minus 4 second window required for frequency hopping, the NCS must transmit as often as necessary to maintain net sync time. A general rule is for the NCS to transmit at least once every 24 hours in a very quiet net and about every half hour in a heavy traffic net.



**CUE RESPONSE**

The NCS or an Alternate NCS is responsible for responding to “CUE” calls. A CUE caller is one who needs an ERF to get back into the secure, FH net, or one who has a VRC-12 type radio and must use the SC mode to communicate. By not loading the CUE frequency, net operators are spared the distraction of “CUE” messages appearing in their RT displays, Also, if the enemy is credited with direction finding capability, the NCS station that responds to a CUE call using single channel mode, should displace Immediately after completing the CUE response.

**RXMT OPERATIONS**

It is the NCS who must anticipate the need for RXMT operations, alert the RXMT crew in time for them to make preparations and move to the RXMT site, and maintain RXMT communications with the distant station. It is the NCS who will also make use of RXMT capabilities to communicate between a frequency hopping and single channel net.

**ALTERNATE NCS**

The NCS has a full time job maintaining net discipline and controlling the net. An important NCS requirement is to make proper use of Alternate NCS stations for critical functions such as responding to CUE calls, entering late members into the net, and continuing to use old data until all net members have changed over to updated data.

**UPDATES**

For periodic updates, the NCS assists the unit Signal Officer in the task of getting some ANCDs reloaded and new data manually distributed to net operators. On those special occasions when it is impossible or impractical to physically disseminate new data, it falls to the NCS to transmit TEKs, FH data, or SOI information by electronic transfer means. Depending upon the state of training and extent of experience, it may be necessary for the unit Signal Officer and communications specialists to assist NCSs in the use of electronic transfer procedures.

**SUMMARY OF TRANSFER METHODS**

TYPE OF DATA  MODE OF DISTRIBUTION	FH DATA					COM SEC		SOI
	NET ID	SYNC TIME	LOCK OUT	HOP SET	TSK	TEK	KEK	SOI EXT
PHYSICAL	YES	YES	YES	YES	YES	YES	YES	YES
ERF	YES	YES	YES	YES	YES	NO	NO	NO
BROADCAST	NO	NO	NO	NO	NO	NO	NO	YES
OTAR	NO	NO	NO	NO	NO	YES	NO*	NO

**Figure 7-1. Summary of Transfer Methods**

\* Although the KEK in receiving radios is automatically updated during an AK OTAR transfer, a KEK cannot be electronically transferred from one location to another:

**6.3. PRIMARY NCS TASKS**

**6.3a. Definition of Primary NCS Tasks**

- WHAT ARE THEY?** There are five tasks categorized as primary for SINCGARS NCS personnel. These five tasks, along with both Primary and Special Operator Tasks, enable a SINCGARS NCS to meet all normal communications requirements when the unit is in an operational situation.
- WHAT' S INVOLVED?** These five primary tasks involve partial transfer of COMSEC/FH data/SOI information from one ANCD to another: both Hot and Cold Start methods of net opening, and responding to CUE calls.
- WHAT' S REQUIRED?** All NCS personnel are expected to be able to perform these five primary tasks without assistance, other than reference to the NCS Pocket Guide, TM 11-5820-890-10-7. Operator Preventive Maintenance Checks and Services (PMCS) (see Chapter 8) are to be performed prior to performing operator or NCS tasks.

**6.3b. Summary of Primary NCS Tasks**

- PRIMARY TASK 1:** **Transfer Partial COMSEC/FH Data, ANCD to ANCD**  
 Used to download selected COMSEC keys or FH data elements from one ANCD to another. This task supplements Special Operator Task 1, "Transfer COMSEC/FH Data From ANCD to ANCD," which transfers complete data loads.
- PRIMARY TASK 2:** **Transfer Selected SOI Information, ANCD to ANCD**  
 Used when less than a complete SOI load is to be downloaded from one ANCD to another. This task supplements Special Operator Task 2 Alternate, "Transfer Full SOI information From ANCD to ANCD," which transfers the complete SOI file.
- PRIMARY TASK 3:** **Conduct Hot Start Net Opening**  
 This is the principal method used for net openings; operators load all required data and sync time and, at the prescribed net opening time, call the NCS and enter the secure. FH net.
- PRIMARY TASK 4:** **Conduct Cold Start Net Opening**  
 This is an alternate method for opening the net. It requires operators to load COMSEC and FH data, standby to receive an ERF containing sync time, and properly storing the ERF. It requires close coordination and correct operator actions. It may be used in situations where the NCS wants all operators to enter the net at the exact same time.
- PRIMARY TASK 5:** **Respond to CUE Calls**  
 This task is performed whenever the "CUE" message appears in the NCS' s RT display. In that response to a CUE message requires leaving the operational net, transmitting in SC mode, possibly sending an ERF, and probably displacing physically to avoid enemy direction finding, the NCS designates an Alternate NCS to respond to the CUE call.

**6.3c. Transfer Partial COMSEC/FH Data, ANCD to ANCD (Primary NCS Task 1)**

**DESCRIPTION**

In addition to transferring complete SOI files, quick reference or full SOIs, an NCS is expected to be able to transfer partial data loads. For example, performance of this task enables the NCS to transfer specific loadsets, Esets, COMSEC keys, TSKs, or sync time from one ANCD to another. This capability facilitates dissemination within the unit when less than total data is required. There are three options associated with this task, allowing the NCS to perform selected special functions.

**DETAILED FLOWCHART**

NCS personnel perform the actions required in each subtask. in the order shown. Results are shown as ANCD displays (dark bordered boxes), or as RT displays in the form of "RT display shows." Where appropriate, results are expressed as explanations of occurrences.

**TRANSFER PARTIAL COMSEC/FH DATA, ANCD TO ANCD**

SUBTASKS	ACTIONS	RESULTS
<p>a. Prepare Source ANCD for partial data transfer*</p>	(1) Turn ANCD ON	select. Soi <b>Radio</b> sUpervisor
	(2) Enter RADIO	Send Receive Database sEtop Comsec Time
	(3) Enter SEND	send to: Radio <b>Ancd</b> Stu Pc
	(4) Enter ANCD	Loadset** Database Time** Key** Eset** Mwod***
	(5) Enter LOADSET	select: Loadset (name) ENTR
	(6) Scroll (PgUP/PgDN) to loadset desired, ENTR	Do you want to include time? (Y/N)
	(7) Respond YES (unless you want to omit time)	Connect to ANCD and press [SEND] <b>(WAIT)****</b>

SUBTASKS	ACTIONS	RESULTS
<b>b. Prepare Target ANCD for partial data transfer</b>	(1) Turn ANCD ON	select: Soi <b>Radio</b> supervisor
	(2) Enter RADIO	Send <b>Receive</b> Database sEtuP Comsec Time
	(3) Enter RECEIVE	receive from: <b>Ancd</b> Cfd Stu PC Mx
	(4) Enter ANCD	<b>Loadset</b> Database Time Key Eset Mwod***
	(5) Enter LOADSET	Connect to ANCD and press [RCV] <b>(WAIT)</b> ****
<b>c. Perform data transfer</b>	(1) Press [SEND] on Source ANCD	Transfer successful [↓]
	(2) Press [RCV] on Target ANCD	select: <b>Replace</b> iNsert (data item name)*****
	(3) Enter REPLACE	Transfer successful (Task IS completed)

\* When replacing or overwriting keys, new COMSEC and FH data must be named the same as those to be replaced or overwritten.

\*\* You may select Loadset, Eset, Key, or Time. The item selected for transfer to the Target ANCD must be the same as that selected for the Source ANCD.

\*\*\* MWOD (multiple word of day) is a term used in loading procedure for Have Quick radios found in selected aircraft radios.

\*\*\*\* **Do not** press [SEND] until ready to press [RCV]. Then press [RCV] within 20 seconds of pressing [SEND].

\*\*\*\*\* This screen will appear only if the data item name exists in the Target ANCD.

**6.3d. Transfer COMSEC Key From ANCD to RT (NCS Option 1A)**

**DESCRIPTION**

This optional task enables an NCS to transfer COMSEC keys from an ANCD to a SINCGARS radio. It is a variation of Primary NCS Task 1. Although the flowchart below shows the detailed procedure for transfer of a COMSEC key to an RT, this procedure can also be used to transfer COMSEC keys from an ANCD to a KYK-13 or KYX-15 if desired.

**DETAILED FLOWCHART**

**TRANSFER COMSEC KEY FROM ANCD TO RT**

SUBTASK	ACTIONS	RESULTS
<b>a. Prepare ANCD for transfer of COMSEC key</b>	(1) Turn ANCD ON	select: Soi <b>Radio</b> sUpervisor
	(2) Enter RADIO	Send Receive Database sEtap <b>Comsec</b> Time
	(3) Enter COMSEC	vG Ld Rv Ak Mk vU
	(4) Enter LD	select: Tek* Kek
	(5) Enter TEK or KEK as desired	<b>Select key</b> qUit (name/number) ENTR
	(6) Select key and press ENTR	Select key <b>qUit</b> (key selected) XMT
	(7) Enter QUIT	Connect ANCD to RT** [↓]
<b>b. Transfer key from ANCD to RT</b>	(1) Connect ANCD to RT using fill cable, press	Press [LOAD] on RT***
	(2) Press RT [LOAD] / [STO] / [X]	Transfer of COMSEC key is completed

\* Remember that CUE and MAN channels use the TEK in channel 5. Do not change this key unless you are sure the new key is to be used for CUE and MAN channels also.

\*\* Connect ANCD to RT, or to KYK-13 or KYX-15.

\*\*\* The same procedure may be used for COMSEC devices.

**6.3e. Designate New Default Loadset (NCS Option 1B)**

**DESCRIPTION**

This optional task allows an NCS to change the designation of the default loadset stored in the ANCD. This function is useful during periodic updating, for example, when the current loadset is to be replaced by one which was carried in reserve in the ANCD database. By changing the default, the NCS makes it easy for operators or communications specialists to transfer a new loadset to other ANCDs of the unit, or to load the default loadset into radios.

**DETAILED FLOWCHART**

**DESIGNATE NEW DEFAULT LOADSET**

SUBTASKS	ACTIONS	RESULTS
Change default loadset	(1) Turn ANCD ON	select: Soi <b>Radio</b> supervisor
	(2) Enter RADIO	Send Receive Database <b>sEtu</b> p Comsec Time
	(3) Enter SETUP	select: <b>iCom</b> Nonicom
	(4) Enter ICOM*	select: <b>Loadset</b> None
	(5) Enter LOADSET	select: Loadset (name) ENTR (DI)**
	(6) Select loadset and press ENTR***	Select: iCom Nonicom
	(7) Press ABORT	Send Receive Database sEtu Comsec Time

\* Also use ICOM designation when preparing to fill an RCU.

\*\* Loadsets are identified with a "D" indicating defaultloadset, followed by an "I" for ICOM or an "N" for Non-ICOM.

\*\*\* ICOM fill will now load new/y designated loadset.

**6.3f. Change Eset in One Channel of RT (NCS Option 1C)**

**DESCRIPTION**

This optional task enables the NCS to change or replace the Eset (FH data) in one channel of the radio. The preferred solution to this change requirement is to load a new loadset. When loading a new loadset is infeasible, this procedure allows the FH data in one channel of the radio to be changed without interfering with other channel loadings.

**DETAILED FLOWCHART**

**CHANGE ESET IN ONE CHANNEL OF RT**

SUBTASKS	ACTIONS	RESULTS
Change Eset in one channel of loadset	(1) Turn ANCD ON	select: Soi <b>Radio</b> supervisor
	(2) Enter RADIO	Send Receive <b>Database</b> sEtuP Comsec Time
	(3) Enter DATABASE	select: Display <b>Modify</b> Remove Copy build*
	(4) Enter MODIFY	select: Loadset (name) ENTR (DI)
	(5) Select loadset and press ENTR	<b>Replace</b> Delete ESET #: (name)** ENTR
	(6) Enter REPLACE, select ESET, and press ENTR	select: <b>Eset</b> qUit
	(7) Enter ESET	select: Eset <b>(name)***</b> ENTR
	(8) Select new Eset and press ENTR	Modify another loadset element? (Y/N)
	(9) Respond NO	select: <b>Replace</b> iNsert (name)

\* The "bUild" feature should not be used unless you are specifically trained to perform this task. Serious database errors can occur if incorrect procedures are used.

\*\* At this point, select the Eset you wish to replace.

\*\*\* At this point, select your replacement Eset by name.

**6.3g. Transfer Selected SOI Information, ANCD to ANCD (Primary NCS Task 2)**

**DESCRIPTION**

Although Primary Operator Tasks 2 and 2 Alternate provide for the transfer of full or quick reference SOI Information, an NCS may at times need to transfer only selected items of SOI information. For example, it may be necessary to transfer only one SOI set (5 days of information). the detailed procedure shown below uses an SOI set for the example. Steps to be taken are the same for other categories of SOI information. This task involves preparing the Source and Target ANCD, plus performing the data transfer.

**DETAILED FLOWCHARTS**

**TRANSFER SELECTED SOI INFORMATION, ANCD TO ANCD**

SUBTASKS	ACTIONS	RESULTS
a. Prepare Source ANCD for selected SOI transfer*	(1) Turn ANCD ON	select: <b>Soi</b> Radio sUpervisor
	(2) Enter SOI	qRef Group Net sufX Pyro Tmpd <b>Set C/s</b> Find Memo
	(3) Enter SET	select: Choose <b>Send</b> Receive
	(4) Enter SEND	Scroll (↓/↑) & press ENTR to select SOI [↓]
	(5) Press down arrow	SOI Set: (name/nr) Edn: (name/tp)
	(6) Press ENTR to select SOI and edition desired	Do you want to transfer QREF?**(Y/N)
	(7) Respond NO	Do you want to specify groups to send? (Y/N)
	(8) Respond YES	Scroll (←/→) & press ENTR to select groups
	(9) Press ENTR to select groups desired	1 groups selected - Keep selecting? (Y/N)
	(10) Respond NO (when through selecting)	Do you want to specify a time pd to send? (Y/N)
	(11) Respond YES	Enter Time Pd (#-#) = > # #
	(12) Enter Time Period desired	Include Suffix & Smoke/Pyro data? (Y/N)
	(13) Respond YES	Send to: <b>Ancd</b> Pc Broadcast



SUBTASKS	ACTIONS	RESULTS
	(14) Enter ANCD	Do you want to save this new SOI set? (Y/N)
	(15) Respond YES	New SOI set name: = > ????????????
	(16) Enter SOI set name	Connect ANCD to ANCD [↓]
	(17) Connect ANCDs and press down arrow	Press [SEND] to send (WAIT)***
<b>b. Prepare Target ANCD for selected SOI transfer</b>	(1) Turn ANCD ON	select: <b>Soi</b> Radio sUpervisor
	(2) Enter SOI	qRef Group Net sufX Pyro Tmpd <b>Set</b> C/s Find Memo
	(3) Enter SET	select: Choose Send <b>Receive</b>
	(4) Enter RECEIVE	receive from: <b>Ancd</b> Pc Broadcast
	(5) Enter ANCD	Connect ANCD to ANCO [↓]
	(6) Press down arrow	Press [RCV] to receive (WAIT)***
<b>c. Perform transfer of selected SOI</b>	(1) Press [SEND] on Source ANCD	Processing. Please wait. (shows % of bytes sent)
		Sending of SOI data is completed
	(2) Press [RCV] on Target ANCD	Processing. Please wait. (shows number of bytes sent)
		Receive operation was successful

\* If you wish to transfer a complete SOI, refer to Special Operator Task 2 Alternate.

\*\* If this screen appears, respond NO. Either QREF or selected SOI information can be transferred using this procedure, but not at the same time. If you wish to transfer a QREF file, you may use this procedure or refer to Special Operator Task 2. (To develop a QREF file, merely scroll to SOI items desired and press "K" (for KEEP) to place each item in QREF

\*\*\* **Do not** press [SEND] until you are ready to press [RCV]. Then press [RCV] within 20 seconds of pressing {SEND}.

**6.3h. Conduct Hot Start Net Opening (Primary NCS Task 3)**

**DESCRIPTION**

This task represents a basic NCS requirement, to open the SINGARS secure, frequency hopping net. During use of the Hot Start net opening procedure, NCS responsibilities are primarily supervisory in that each operator loads the radio with COMSEC keys, FH data, and sync time in preparation for the net opening. Upon completing the ICOM fill (which loads COMSEC, FH data, and sync time into all six RT channels), the operator merely calls the NCS in secure, FH mode, and requests permission to enter the net. NCS requirements are limited to ensuring that operators are provided the required data for net opening and respond to operator requests for net entry.

**DETAILED FLOWCHART**

**CONDUCT HOT START NET OPENING**

SUBTASKS	ACTIONS	RESULTS
<b>a. Prepare NCS radio for Hot Start net opening</b>	(1) Load CUE, MAN, and SC freqs, as required	(Perform Primary Operator Task 1)
	(2) Load COMSEC keys, FH data, and sync time*	(Perform Primary Operator Task 2)
<b>b. Prepare net operators for Hot Start net opening</b>	(1) Ensure net ANCDs are properly loaded**	N/A
	(2) Advise operators when net is to be opened	N/A
<b>c. Open the net</b>	(1) Respond to individual operator calls	(Each operator calls as soon as ready to enter the net)
	(2) Admit individual operators into CT, FH net	(When all operators have called, Hot Start is complete)

\* The ANCD automatically converts current date to a two -digit Julian Date. There is no action required on the part of the operator.

\*\* Unit SOP should specify if net RTs are to be loaded by individual operators or by communications specialists and designated NCOs. Centralized loading of radios may be an attractive solution when the state of individual operator training is a consideration.

**6.3i. Conduct Cold Start Net Opening (Primary NCS Task 4)**

**DESCRIPTION**

The Cold Start net opening procedure has for most units been replaced by the simpler, less demanding, Hot Start method covered in Primary NCS Task 3, above. The Cold Start method remains an option for NCSs to use if desired. The Cold Start net opening procedure requires operators to load their radios with COMSEC keys and FH data, but not sync time. Sync time is passed electronically from the NCS to net members by ERF. Coordination is essential to ensure that all operators are ready when the ERF is sent and that they properly store the data. While the Cold Start method works, experience has shown that coordination requirements and operator actions make it a more demanding process than the Hot Start method. It is available for use whenever an NCS needs to bring all operators into the net at the exact same time.

**DETAILED FLOWCHART**

**CONDUCT COLD START NET OPENING**

SUBTASKS	ACTIONS	RESULTS
<b>a. Prepare NCS radio for Cold Start net opening</b>	(7) Load CUE, MAN and SC freqs, as required	(Perform Primary Operator Task 1)
	(2) Load COMSEC keys, FH data, and sync time*	(Perform Primary Operator Task 2)
<b>b. Prepare net operators for Cold Start net opening</b>	(1) Ensure all operator RTs are properly loaded	(Operators perform an ICOM fill less sync time)
	(2) Advise operators when the net is to be opened	(Operators must be standing by at exact net opening time)
<b>c. Send ERF at announced net opening time</b>	(1) Alert net that ERF is to be sent at this time**	(Helps operators note when ERF is received)
	(2) Press [LOAD] on RT	RT display shows "HLD" (Get data from what chan?)
	(3) Enter channel in which ERF data is stored	RT display shows "HF XXX," blinks and beeps
	(4) Press [ERF] on RT	RT display shows "SEND"

SUBTASKS	ACTIONS	RESULTS
d. Confirm receipt of ERF	(1) Allow operators time to store the ERF	(20-30 seconds should be adequate)
	(2) Direct operators to ACK receipt of ERF	(NCS and operators continue to use MAN in CT for ACK)
e. Make communications check	(1) Direct operators to go to SQ ON, operational chan	(Net shifts to the FH mode of communications)
	(2) Set NCS radio to SQ ON and operational chan	N/A
	(3) Check communications with net operators	(Note which operators do not respond)
	(4) Direct Alt NCS to bring all other operators into net***	Cold Start is complete when all operators have entered net

\* Sync time may be loaded into the radio from an ANCD, a PLGR, via ERF; or by use of the RT keypad. The preferred method is to load exact GPS time and Julian Date directly from an ANCD or PLGR.

\*\* Depending upon operational conditions and state of operator training, you may wish to have operators acknowledge this announcement,

\*\*\* Ensure that operators understand that if they fail for any reason to enter the net at the time the ERF is sent, they are to standby on MAN and wait for you to contact them there.

**6.3j. Respond to CUE Calls (Primary NCS Task 5)**

**DESCRIPTION**

An important feature of the SINCGARS radio is its ability to be contacted by a non-frequency hopping radio, or an FH radio lacking data or sync time, through a process known as “CUEing.” All that is required is for the calling radio to be on the prescribed CUE frequency, press the push-to-talk switch, and wait for a response. This action causes a “CUE” message to appear in the RT display of the NCS and Alternate NCSs.

**DETAILED FLOWCHART**

**RESPOND TO CUE CALLS**

SUBTASKS	ACTIONS	RESULTS
<b>a. Note CUE message in RT display*</b>	(1) Switch from operational channel to CUE, in CT	N/A
	(2) Call CUE caller using CUE chan and CT mode	(Keep SC messages as brief as possible)
<b>b. Assist CUE caller as required</b>	(1) Upon contact, direct caller to go to MAN and CT	N/A
	(2) Determine CUE caller's requirement	N/A
	(3) Provide CUE caller an ERF if required**	(See Primary NCS Task 4 or Special Operator Task 7)
	(4) Admit caller to net if authorized	N/A
<b>c. Resume normal communications</b>	(1) Return to operational channel	(Do not leave your net if an Alt NCS is available)
	(2) If enemy has DF capability move to new location	(Alt NCS should be prepared to displace frequently)

\* Either the NCS or Alt NCS may respond to CUE calls. The preferred solution is for an Alt NCS to respond to CUE calls, leaving the NCS free to control the net.

\*\* An Alt NCS may use the FH-M position to send an ERF on the MAN channel while the NCS continues to use FH-M on the operational channel without interfering with net sync time.

## **6.4. SPECIAL NCS TASKS**

### **6.4a. Definition of Special NCS Tasks**

<b>WHAT ARE THEY?</b>	There are five tasks categorized as special for SINCGARS NCS personnel. These five tasks enable a SINCGARS NCS to electronically transfer FH data (to include a TSK), SOI information, and COMSEC keys (TEK only).
<b>WHAT' S INVOLVED?</b>	The preferred method of updating these categories of data is by physical connection of ANCD to ANCD. When the tactical situation makes physical transfer impossible or impractical, these electronic transfer means may be used.
<b>WHAT' S REQUIRED?</b>	All SINCGARS NCS personnel should receive at least familiarization training in these tasks. In units which anticipate frequent mission-related requirements for electronic data transfer, NCS operators should be trained to proficiency. In that many units will but rarely have a need to use electronic data transfer, the assistance of the Signal Officer/NCOs may be required for their NCSs to perform these tasks correctly.

### **6.4b. Summary of Special NCS Tasks**

<b>SPECIAL NCS TASK 1:</b>	<b><u>Transfer Updated FH Data via Net Update ERF</u></b> Used for electronic transfer of FH data (hopset, net ID, TSK) from one location to another, Net update ERF may also include a change in sync time if desired.
<b>SPECIAL NCS TASK 2:</b>	<b><u>Transmit SOI information Using the Broadcast Mode</u></b> This is the procedure used for electronic transfer of SOI information from one location to another. Because of the time required to transfer SOI data by Broadcast, each transmission is normally limited to one time period.
<b>SPECIAL NCS TASK 3:</b>	<b><u>Send TEK to Other NCSs Using the MK Method of OTAR</u></b> This is the principal method of electronically transferring a TEK from one location to another. The MK (manual key) procedure moves TEK from a Source ANCD, through the Source NCS RT through the Target NCS RT, into the Target NCS' s ANCD.
<b>SPECIAL NCS TASK 4:</b>	<b><u>Send TEK to Net Operators Using the AK Method of OTAR</u></b> This is a method for disseminating a new TEK by electronic transfer with a net. The procedure moves the new TEK from the NCS' s ANCD, through the NCS' s radio, directly into the radios of net operators.
<b>SPECIAL NCS TASK 5:</b>	<b><u>Receive and Store TEK Sent by MK Method of OTAR</u></b> This is the procedure followed by Target NCSs when a Source NCS sends a TEK by MK OTAR (Special NCS Task 3, above). This task enables the receiving NCSs to store the electronically transmitted TEK in an ANCD, where it is readily available for further distribution within the unit when required.

**6.4c. Transmit Updated FH Data Via Net Update ERF (Special NCS Task 1)**

**DESCRIPTION**

This task enables the NCS to electronically transmit new FH data to net operators when distribution by physical connection of ANCD to ANCD is impossible or impractical. This procedure may be used to update (change) hopsets, TSKs, net IDs, and sync time. The task involves alerting net operators, sending the ERF using the net operational channel, confirming receive of the ERF, and making a communications check when the changed FH data is put into effect.

**DETAILED FLOWCHART**

**TRANSMIT UPDATED FH DATA VIA NET UPDATE ERF**

SUBTASKS	ACTIONS	RESULTS
<b>a. Prepare to send net update ERF</b>	(1) Obtain updated FH data; and effective time	(Obtain from SigO, ANCD, or SOI as appropriate)
	(2) Load new FH data into NCS radio*	(Perform ICOM fill or change Eset in one channel)
<b>b. Prepare net operators for net update ERF</b>	(1) Alert net that an update ERF is to be sent	(Wait until the net is clear of operational traffic)
	(2) Tell operators what channel to store ERF	(Facilitates channel change when data is effective)
	(3) Advise operators when new FH data is effective	(May be immediate or at a later specified time)
<b>c. Send net update ERF</b>	(1) Set FCTN to LD	(If NCS RT is not in FH-M, set it there for sending ERF)
	(2) Press [LOAD] on RT	RT display show "HLD _"
	(3) Enter channel where ERF data is stored	RT display shows "HF XXX," blinks, and beeps
	(4) Press [ERF] on RT keypad	RT display shows "SEND," beeps, and shows "HF XXX"
	(6) Change FCTN from LD back to SQ ON	N/A

SUBTASKS	ACTIONS	RESULTS
<b>d. Confirm receipt of ERF</b>	(1) Allow operators time to store net update ERF	(20-30 seconds should be adequate)
	(2) Have operators ACK receipt of ERF	N/A
	(3) Have Alt NCS repeat ERF if required by operators	(Allows NCS to control net and continue net operations)
<b>e. Make communications check</b>	(1) At proper time, change to update ERF data	N/A
	(2) Check communications using update ERF data	N/A
	(3) Have Alt NCS follow up for non-responsive operators	Net update ERF is completed

- *Store data to be sent by ERF in a channel other than your operational channel. Net update ERF is transmitted over the operational channel.*



**6.4d. Transfer SOI Information Using Broadcast Mode (Special NCS Task 2)**

**DESCRIPTION**

This procedure enables an NCS to send SOI Information electronically to net members wherever updating by physical connection of ANCD to ANCD proves to be impossible or impractical. The Broadcast Mode requires approximately two minutes to transmit one time period of a battalion SOI extract. The procedure includes a polling feature which allows the NCS to determine by automatic query if up to 16 net operators (designated by special ID numbers) did or did not receive the SOI information sent by Broadcast.

**DETAILED FLOWCHART**

**TRANSFER SOI INFORMATION USING BROADCAST MODE**

SUBTASKS	ACTIONS	RESULTS
a. Prepare NCS radio to send SOI by broadcast	(1) Ensure RT is set to SQ ON, CT, and FH-M	N/A (Normal NCS RT settings)
	(2) Change DATA from OFF to 1200	Broadcast (uses data mode set to 1200 bps)
b. Prepare ANCD for SOI data broadcast  # This screen will appear only if QREF file is stored in ANCD	(1) Turn ANCD ON	select: <u>Soi</u> Radio sUperVlsor
	(2) Enter SOI	qRef Group Net sufX Pyro Tmpd <u>Set</u> C/s Find Memo
	(3) Enter SET	select: Choose <u>Send</u> Receive
	(4) Enter SEND	Scroll ( ↑/↓ ) & press ENTR to select SOI set [↓]
	(5) Press down arrow	SOI Set: (name) Edn: (name)
	(6) Press (↑/↓) to display; and press ENTR to select	Do you want to transfer QREF?# (Y/N)
	(7) Respond NO	Do you want to specify groups to send? Y/ <u>N</u>
	(8) Respond YES	Scroll (↑/↓) & press ENTR to select groups [↓]
	(9) Press (↑/↓) to display; and press ENTR to select	1 group selected - keep selecting? (Y/ <u>N</u> )
	(10) Enter YES to continue; enter NO to quit	Do you want to specify a time pd to send? ( <u>Y</u> /N)

SUBTASKS	ACTIONS	RESULTS
	(11) Respond YES	Enter Time Pd (# - #) = > # #
	(12) Enter Time Period; and press ENTR	Include Suffix & Smoke/Pyro data? (Y/N)
	(13) Respond YES to include; respond NO to exclude	Send to: Ancd Pc <b>Broadcast</b> Stu
	(14) Enter BROADCAST	Enter ID for each polled ANCD; and 0 when done* [↓]
	(15) Press down arrow	Polled: 1234567890123456 = > # #
	(16) Enter IDs for polling (see example; press ENTR	Polled: 12*456**901*34*6 = > # #
	(17) Enter "0" to quit	Do you want to save this SOI set? (Y/N)
	(18) Respond YES (to save SOI data	New SOI set name: = > ??????????
	(19) Enter SOI set name; and press ENTR	Connect ANCD to RT AUD/DATA [↓]
	(20) Press down arrow	Press SEND to send <b>(WAIT)**</b>
<p><b>c. Prepare net operators for receipt of SOI Broadcast</b></p>	(1) Say:Standby for Broadcast follow my instructions/ACK	Alerts net members to an Immediate requirement
	(2) After ACK, say:Go to SQ ON,FH, CT DATA- 1200	Ensures net radios and ANCDs are properly prepared
	(3) Say:Turn ANCD ON	select: <b>Soi</b> Radio supervisor
	(4) Say:Enter SOI	qRef Group Net sufx Pyro Tmpd Set C/s Find Memo
	(5) Say:Enter SET	select: Choose Send <b>Receive</b>
	(6) Say:Enter <u>RECEIVE</u>	receive from: Ancd Pc <b>Broadcast</b> Stu
	(7) Say:Enter <u>BROADCAST</u>	Enter broadcast ID (1 - 16): = > # #

SUBTASKS	ACTIONS	RESULTS
	(8) Say: <u>Enter SOP broadcast ID: and press ENTR</u>	BROADCAST ID set to X Polling: ON/OFF {↓}
	(9) Say: <u>Press down arrow</u>	Connect ANCD to RT AUD/DATA {↓}
	(10) Say: <u>Connect ANCD to RT AUD/DATA; HS to Aud/Fill</u>	(Emphasize AUD/DATA for ANCD connection)
	(11) Say: <u>When ready, press down arrow and ACK</u>	Press RCV to receive <b>(WAIT)**</b>
<b>d. Send SOI information by Broadcast Mode</b>	(1) Say: <u>Standby, broadcast will now be sent; press RCV now; sending now</u>	Alerts operators that broadcast is about to be sent; coordinates pressing of SEND and RCV
	(2) Press [SEND] on NCS ANCD**	Processing. Please wait.
		Sending of SOI data completed

\* *If polling is used, the NCS ANCD will indicate which stations did and did not receive the broadcast. If polling is not used, the NCS should have net members acknowledge receipt of SOI data.*

\*\* *Do not press [SEND] until net members are ready at your direction to press [RCV]. Then press [SEND] within 20 seconds of having operators press [RCV].*

**6.4e. Send TEK to Other NCSs Using MK Method of OTAR (Special NCS Task 3)**

**DESCRIPTION**

This procedure allows an NCS to transfer a TEK (not a KEK) electronically, over-the-air-rekey (OTAR) to other NCSs. This capability is useful when the tactical situation or terrain makes it impossible or impractical to pass new TEK by physical connection of ANCD to ANCD. Receiving NCSs store the new TEK in their ANCDs. The new TEK can then be passed to operators by physical transfer. Special NCS Tasks 3 and 5 are performed together by Source and Target NCSs, respectively.

**DETAILED FLOWCHART**

**SEND TEK TO OTHER NCSs USING MK METHOD OF OTAR**

SUBTASKS	ACTIONS	RESULTS
<p><b>a. Prepare Source NCS radio to send MK OTAR*</b></p>	(1) Set FCTN to SQ ON	N/A
	(2) Set MODE to FH-M	N/A
	(3) Set COMSEC to CT	N/A
	(4) Set DATA to OFF	N/A
<p><b>b. Prepare Source ANCD to send MK OTAR</b></p>	(1) Turn ANCD ON	select: Soi <b>Radio</b> supervisor
	(2) Enter RADIO	Send Receive Database sEtap <b>Comsec</b> Time
	(3) Enter COMSEC	Vg Ld Rv Ak <b>Mk</b> vU
	(4) Enter MK	Select key qUIT (name/number)
	(5) Press PgDN to display; and ENTR to select	Connect to RT and press [SEND] <b>(WAIT)**</b>
	(6) Connect Source ANCD to RT using fill cable	N / A

SUBTASKS	ACTIONS	RESULTS
<p><b>c. Prepare Target NCSs to receive MK OTAR</b></p>	<p>(1) Say:Standby for MK OTAR, ACK</p>	<p>Target NCSs are alerted; CT contact is confirmed</p>
	<p>(2) After ACK, say:Make Special NCS Task 5 preparations; ACK when ready to receive MK OTAR</p>	<p>Readies Target NCSs to receive MK OTAR</p>
	<p>(3) After ACK, say:OTAR will now be sent; after receipt of OTAR return to chan 1</p>	<p>Provides final coordination guidance for MK OTAR</p>
<p><b>d. Send TEK by MK OTAR***</b></p>	<p>(1) Say:Go to chan 6 now; press [RCV] now</p>	<p>N/A</p>
	<p>(2) Go to chan 6 and press [SEND] now</p>	<p>Transfer in Progress/ 1 Keys Transferred</p>
	<p>(3) Return to chan 1</p>	<p>Prepares Source NCS radio for comm with Target NCSs</p>
	<p>(4) Wait 30 set after sending; say:OTAR completed; TEK ID is XXXXX: effective at (DTG), ACK****</p>	<p>Informs Target NCSs of TEK ID and effective time; advises Source NCS which stations did and did not receive OTAR</p>

\* In using the MK OTAR procedure, there is considerable advantage if an Alternate NCS takes the primary role in sending the OTAR. For example, an Alternate NCS can load the new TEK into a second SINCGARS radio, or into a TEK position other than that be used for the operational net. This means that once the OTAR has been sent, the Alternate NCS can monitor communications using both new and old TEKs, thus making it easier to bring in any stations that missed receiving the initial OTAR.

\*\* Do **not** press [SEND] until Target NCSs are ready to press [RCV]. Then press [SEND] within 20 seconds of directing them to press [RCV].

\*\*\* If distance or obstacles between NCS stations requires it, an RXMTstation may be used in transmitting an MK OTAR. Transmitting and receiving stations must have the same KEK loaded in channel 6. The fact that the RXMT link requires use of two net IDs does not change the requirement to use the same KEK.

\*\*\*\* The Alternate NCS notes which stations still need the OTAR, keeps one channel on the old TEK, and sends the MK OTAR to remaining Target NCS as contact is re-established, or at a prescribed time.

**6.4f. Send TEK to Net Operators Using AK Method of OTAR(Special NCS Task 4)**

**DESCRIPTION**

This procedure enables an NCS to transfer electronically a TEK (not a KEK) directly from the NCS ANCD to net member radios. In the AK method, the TEK transferred to net member radios automatically, and instantaneously, replaces the TEK being used. Also, the KEK in net member radios is automatically updated (changed) during the AK procedure. After sending a TEK by AK OTAR, the Source NCS must load the new TEK. While the AK method of OTAR requires no action on the part of receiving net members, it is quite demanding of the Source NCS.

**DETAILED FLOWCHART**

**SEND TEK TO NET OPERATORS USING AK METHOD OF OTAR**

SUBTASKS	ACTIONS	RESULTS
<b>a. Prepare Source NCS radio to send AK OTAR</b>	(1) Set FCTN to LD	N/A
	(2) Set MODE to FH-M	N/A
	(3) Set COMSEC to CT	N/A
	(4) Set DATA to OFF	N/A
<b>b. Prepare Source NCS ANCD to sent AK OTAR</b>	(1) Turn ANCD ON	select: Soi <b>Radio</b> supervisor
	(2) Enter RADIO	Send Receive Database sEtap <b>Comsec</b> Time
	(3) Enter COMSEC	vG Ld Rv <b>Ak</b> Mk vU
	(4) Enter AK	Select key quit (name/number)
	(5) Press PgU/PgDN to KEK(s) desired; then press ENTR	Select key <u>quit</u> (name/number) KEK
	(6) Enter QUIT	Select key qUit (name/number)
	(7) Press PgDN to TEK desired; then press ENTR	Connect to RT and press [SEND] <b>(WAIT)*</b>

SUBTASKS	ACTIONS	RESULTS
c. Send AK OTAR**	(1) Say:Standby for AK OTAR, <u>acknowledge</u>	Target operators are alerted, CT contact is confirmed
	(2) Press [SEND] on ANCD	Transfer in progress/ 1 Keys Transferred***  <b>Vg</b> <u>Ld</u> Rv Ak <u>Mk</u> vU
d. Load TEK sent by AK OTAR in NCS radio	(1) Enter LD	select: <b>Te</b> k Kek
	(2) Enter TEK	<b>Select key</b> qUit (name/number)
	(3) Press PgDN to display, and ENTR to select	Select key <b>qUit</b> (name/number) X MT
	(4) Enter QUIT	Connect ANCD to RT  [↓]
	(5) Connect ANCD to RT AUD/FILL, press [↓]	Press [LOAD] on RT
	(6) Press [LOAD] / [STO] / and [X]****	1 Keys Transferred  <b>Vg</b> Ld Rv Ak Mk <u>vU</u>

SUBTASKS	ACTIONS	RESULTS
e. Update KEK used for AK OTAR	(1) Set FCTN to LD and enter VU	<b>Select key</b> qUit (name/number)
	(2) Press PgDN to KEK desired; then press ENTR	Connect to RT and press [RCV]
	(3) Press RCV on ANCD	Transfer in Progress  Enter Text ID = > ??????????????????
	(4) Enter TEXT ID and press ENTR	Key updated successfully [↓]
	(5) Press down arrow	Select key qUit (name/number)
	(6) Press ABORT until screen shown appears	Vg Ld Rv Ak Mk vU
	(7) Enter LD	select: Tek <b>KeK</b>
	(8) Enter KEK	Select key qUit (name/number)
	(9) Press PgDN to display, and ENTR to select	Select key qUit (KEK X) XMT
	(10) Enter QUIT	Connect ANCD to RT [↓]
	(11) Press down arrow	Press [LOAD] on RT
	(12) Press [LOAD] / [STO] / [6]	Transfer in Progress/ 1 Keys Transferred

Do not press [SEND] until net members acknowledge readiness to receive the AK OTAR

\*\* Alternate NCS keeps radio on o/d TEK and KEK, sends AK OTAR to net members who missed original transmission as contact is established. If Alternate NCS has a second radio, new TEK should be loaded into that radio for monitoring of net traffic after original AK OTAR is sent.

- \*\* For ASIP: The sent key is automatically placed in the radio Temp Register and applied to the operational channel. This allows instant communication on new TEK, NCS simply changes channel out, then back into operational channel to contact any operator who did not receive the AK. The in/out step places NCS RT back to original TEK.

- \*\*\* Load new TEK into operational channel because that is where it is stored in net members' radios.



**6.4g. Receive and Store TEK Sent by MK Method of OTAR (Special NCS Task 5)**

**DESCRIPTION**

This task is performed by Target NCSs when a Source NCS electronically transmits a TEK using the MK method of OTAR. This procedure allows Target NCSs to store the new TEK in their ANCDs for physical distribution to net operators when required. The sending NCS directs receiving NCSs to perform this task as an integral part of the MK OTAR process. This task supplements Special NCS Task 3, "Send TEK to Other NCSs Using MK Method of OTAR."

**DETAILED FLOWCHART**

**RECEIVE AND STORE TEK SENT BY MK METHOD OF OTAR**

SUBTASKS	ACTIONS	RESULTS
a. Prepare radio for receipt of MK OTAR	(1) Set FCTN to SQ ON	N/A
	(2) Set COMSEC to CT	N/A
	(3) Set DATA to OFF	N/A
b. Prepare ANCD to receive MK OTAR	(1) Turn ANCD ON	select: Soi <b>Radio</b> sUpervisor
	(2) Enter RADIO	Send Receive Database sEtap <b>Comsec</b> Time
	(3) Enter COMSEC	Vg Ld <b>Rv</b> Ak Mk vU
	(4) Enter RV	Connect to RT Press [RCV] ( <b>WAIT</b> )*
	(5) Connect ANCD to RT AUD/FILL port	N/A
	(6) ACK to Source NCS when ready to receive OTAR	(Responds to Source NCS' s MK OTAR instructions)

SUBTASKS	ACTIONS	RESULTS
<b>c. Receive and store TEK sent by MK OTAR</b>	(1) When NCS directs, go to chan 6, and press RCV	Load in Progress
	(2) Enter Text ID provided by Source NCS	Enter Text ID => ??????????????????
	(3) Enter YES**	Do you want to skip Tag sequence? (Y/N)
		1 Keys Received

- Do not press [RCV] until directed to do so by the Source NCS.

\*\* The "Tag Sequence" involves many questions to which you will probably not know the answer. Use Tag Sequence only when specifically directed to do so by the Source NCS, who will then provide answers to the many questions involved. Otherwise, respond YES to skip the Tag Sequence.

# CHAPTER 7

## S I N C G A R S   A S S O C I A T E D   T A S K S

**IN THIS CHAPTER:**

<b>7.1</b>	<b>GENERAL .....</b>	<b>7-2</b>
<b>7.2</b>	<b>PRECISION LIGHTWEIGHT GPS RECEIVER (PLGR) TASKS .....</b>	<b>7-3</b>
a.	Definition of PLGR Tasks.....	7-3
b.	Summary of PLGR Tasks.....	7-3
c.	Obtain Date and GPS Zulu Time from PLGR (PLGR Task 1).....	7-4
d.	Manually Load PLGR Date and Zulu Time Into PLGR (PLGR Task 2).....	7-5
e.	Load PLGR Date and GPS Zulu Time Into SINGARS RT (PLGR Task 3).....	7-7
f.	Load PLGR Key from ANCD into PLGR (PLGR Task 4).....	7-9
<b>7.3</b>	<b>SECURE TELEPHONE UNIT (STU) TASKS.....</b>	<b>7-11</b>
a.	Definition of STU Tasks .....	7-11
b.	Summary of STU Tasks .....	7-11
c.	Send COMSEC Keys/FH Data From ANCD to ANCD via STU (STU Task 1).....	7-12
d.	Receive COMSEC Keys/FH Data Into ANCD Via STU (STU Task 2) .....	7-13
e.	Send SOI Information From ANCD to ANCD via STU (STU Task 3).....	7-14
f.	Receive SOI Information Into ANCD via STU (STU Task 4).....	7-16
<b>7.4</b>	<b>FREQUENCY HOPPING MULTIPLEXER (FHMUX) TASKS .....</b>	<b>7-17</b>

**7.1. GENERAL**

**SCOPE**

This chapter addresses three items of equipment associated with SINCGARS operations.

**PLGR**

The PLGR, in addition to its primary function of determining position location, serves as the principal source of correct Julian Date and exact GPS Zulu time for SINCGARS net sync time. Julian Date and GPS Zulu time can be downloaded from the PLGR by direct connection to the RT, or by manually loading PLGR time into an ANCD, with subsequent loading of the RT from the ANCD. Additionally, the ANCD can be used as the source of required PLGR keys.

**FHMUX**

FHMUX is a development item which when fielded will allow operation of up to four SINCGARS vehicular radios from a single antenna. Specific guidance regarding the FHMUX will be added to this manual when the system has been approved for fielding and firm procedures have been developed.

**STU**

By connecting the STU to an ANCD, it is possible to transfer COMSEC keys, FH data, and SOI information over commercial or military telephone circuits for unlimited distances. This capability enhances SINCGARS operations for widely dispersed units, and it could be especially useful during mobilization of Reserve Component forces.

## 7.2. PLGR TASKS

### 7.2a. Definition of PLGR Tasks

<b>WHAT ARE THEY?</b>	There are four PLGR tasks which enable a SINCGARS NCS to make use of PLGR-based, GPS Zulu time for net openings and maintaining exact SINCGARS sync time for the duration of operations, however extended they may be.
<b>WHAT' S INVOLVED?</b>	These four PLGR tasks involve reading Julian Date and Zulu time from the PLGR, manually loading PLGR time into an ANCD, electronically loading GPS time directly from the PLGR into a SINCGARS radio, and loading required keys into the PLGR from an ANCD.
<b>WHAT' S REQUIRED?</b>	NCS personnel and operators having ready access to a PLGR should become proficient in PLGR tasks.

### 7.2b. Summary of PLGR Tasks

<b>PLGR TASK 1:</b>	<b>Obtain Date and GPS Zulu Time from PLGR</b>  This task allows an NCS, or operator having a PLGR, to obtain Julian Date and exact GPS Zulu time directly from the PLGR.
<b>PLGR TASK 2:</b>	<b>Manually Load PLGR Date and Zulu Time Into ANCD</b>  This task enables the NCS, or operator having a PLGR, to manually load Julian Date and GPS Zulu time into an ANCD.
<b>PLGR TASK 3:</b>	<b>Load PLGR Date and GPS Zulu Time Into SINCGARS RT</b>  This task permits an NCS or SINCGARS operator to electronically transfer Julian Date and GPS Zulu time directly from the PLGR to the SINCGARS radio by physical connection.
<b>PLGR TASK 4:</b>	<b>Load PLGR Key From ANCD Into PLGR</b>  This PLGR task allows an NCS or SINCGARS operator to load a key from an ANCD into a PLGR whenever required.

**7.2c. Obtain Date and GPS Zulu Time From PLGR (PLGR Task 1)**

**DESCRIPTION**

This task enables the SINCGARS NCS or operator to determine Julian Date and GPS Zulu time directly from the PLGR

**DETAILED FLOWCHART**

**OBTAIN DATE AND GPS ZULU TIME FROM PLGR**

SUBTASKS	ACTIONS	RESULTS
a. Place PLGR into operation	(1) Press PLGR [ON] key	N/A
	(2) Observe PLGR perform self-test	(No action required of NCS or operator)
b. Select proper screen and TFOM	(1) At end of self-test, note this screen*	<b>FIX**</b> <b>FOM 5</b> <b>18T</b> <b>MGRS-New</b> <b>WK 82223e</b> <b>63528n</b> <b>EL-00027m</b> ↑/↓ P
	(2) Press down arrow on PLGR; note this screen	2124:43Z <b>TFOM 4***</b> <b>25-12-94</b> <b>SUN</b> <b>Speed too slow</b> <b>GS &lt; 1 mph</b> ↑/↓ P
c. Read date and time from PLGR screen	(1) Read date as <b>25-12-94****</b>	N/A
	(2) Read time as 2124 hours and 43 sec Zulu	PLGR Task 1 is completed.

\* In this section, PLGR screens are shown in double lined boxes while ANCD screens continue to be shown as dark bordered rectangles.

\*\* A battery powered PLGR will automatically go to standby as soon as satellites have been acquired.

\*\*\* Time Figure of Merit (TFOM) of 8 or less indicates that PLGR is tracking at least one satellite and PLGR time is GPS accurate. For TFOM 9, wait for PLGR to acquire satellites, at which time TFOM will change from 9 to 8 or less. (When first turned on, the PLGR may take as long as 15 minutes to acquire satellites.)

\*\*\*\* When the date read from the PLGR is entered into the ANCD, it is automatically converted to the two-digit Julian Date needed for SINCGARS sync time.

**7.2d. Manually Load PLGR Date and Zulu Time Into ANCD (PLGR Task 2)**

**DESCRIPTION**

This procedure enables an NCS or SINCGARS operator to manually load the date and time obtained from the PLGR into the ANCD. GPS date and Zulu time can then be transferred to other ANCDs and loaded into SINCGARS radios using the ICOM fill procedure.

**DETAILED FLOWCHART**

**MANUALLY LOAD PLGR DATE AND ZULU TIME INTO ANCD**

SUBTASK	ACTIONS	RESULTS
a. Determine GPS date and Zulu time	(1) Perform PLGR Task 1, as shown above	N/A
	(2) Read date and time from PLGR (with TFOM of 8 or less)	<b>2124:43Z</b> <b>TFOM 4</b> <b>25-12-94</b> <b>SUN</b> <b>Speed too slow</b> <b>GS &lt; 1 mph</b> ↑/↓ P
b. Prepare ANCD for loading date and time	(1) Turn ANCD ON	select: Soi Radio <b>sU</b> ppervisor
	(2) Enter SUPERVISOR	Are you authorized to use this feature? (Y/N)
	(3) Respond YES	WARNING - This could cause data loss [↓]
	(4) Press down arrow	Are you sure you want to continue? (Y/N)
	(5) Respond YES	Appl <b>Date</b> Time Setup Util Bit {MAIN}

SUBTASK	ACTIONS	RESULT
c. Load new date and time	(1) Enter DATE	Date is Sat 12-24-1994 New mm-dd-yy:
	(2) Enter new date in form of mm-dd-yy	Date is Sat 12-24-1994 New mm-dd-yy:12-25-94 [ENTR]
	(3) Press ENTR	Appl Date <b>Time</b> Setup Util Bit {MAIN}
	(4) Enter TIME	Time is 14:53:27 New hh:mm:ss:
	(5) Enter new time in form of hh:mm:ss	Time is 14:53:27 New hh:mm:ss:21:25:00 [ENTR]
	(6) Press [ENTR] when PLGR reads 25:00*	<b>Appl</b> Date Time Setup Util Bit {MAIN}
	(7) Enter APPL	SOI RADIO <b>RDS</b>
	(8) Enter RDS	select: Soi Radio** sUpervisor

\* Enter one minute beyond PLGR time and wait until PLGR seconds reach 00 to press ENTR on ANCD. Because the ANCD requires time to load, you may find that pressing ENTR on the ANCD when PLGR time reads :59 gives you a more accurate entry.

\*\* To check the accuracy of your ANCD time entry, enter RADIO, then TIME. You can then read ANCD time in running format and compare it with running PLGR time. If the two times are more than one second different, reload PLGR time into your ANCD.



**7.2e. Electronically Load PLGR Date and Zulu Time Into RT (PLGR Task 3)**

**DESCRIPTION**

This procedure allows an NCS or SINCGARS operator to transfer date and time directly from a PLGR into a SINCGARS radio. It represents the preferred method of loading sync time into an RT when a PLGR is available, especially for NCS personnel.

**DETAILED FLOWCHART**

**ELECTRONICALLY LOAD PLGR DATE AND GPS ZULU TIME INTO RT**

SUBTASKS	ACTIONS	RESULTS
<p><b>a. Prepare PLGR to perform transfer task</b></p>	(1) Turn PLGR ON	N/A
	(2) Observe PLGR perform its self-test	N/A
	(3) Note this PLGR screen appear	FIX                      FOM 5 18T                        MGRS- New WK 82223e              63528n EL-00027 m            ↑/↓ P
	(4) Press PLGR MENU key two times; note this screen	DATA-XFR            SV-SEL DOP-CALC             ALERTS SINCGARS             KOI-18 <span style="float: right;">&lt;more&gt; P</span>
	(5) Press PLGR right arrow four times to highlight SINCGARS	DATA-XFR            SV-SEL DOP-CALC             ALERTS <b>SINCGARS</b> KOI-18 <span style="float: right;">&lt;more&gt; P</span>
	(6) Press PLGR down arrow to select SINCGARS	SINCGARS Start time fill ACTIVATE                                      QUIT
	(7) Press PLGR left arrow to highlight ACTIVATE (Do NOT press down arrow yet)	SINCGARS Start time fill <b>ACTIVATE</b> QUIT

SUBTASKS	ACTIONS	RESULTS
<b>b. Prepare RT for time transfer from PLGR</b>	(1) Connect PLGR to RT AUD/FILL port	N/A
	(2) Set RT FCTN to LD	N/A
<b>c. Perform date/time transfer from PLGR to FIT</b>	(1) Press PLGR down arrow to select ACTIVATE	SINGARS Press LOAD key on radio QUIT
	(2) Press LOAD on RT	SINGARS time fill successful QUIT
	(3) Press PLGR down arrow to select QUIT	Date/time transfer is completed

**7.2 f. Load PLGR Key From ANCD Into PLGR (PLGR Task 4)**

**DESCRIPTION**

This procedure enables an NCS or PLGR operator to transfer a PLGR key from the ANCD to the PLGR when required.

**DETAILED FLOWCHART**

**LOAD PLGR KEY FROM ANCD INTO PLGR**

SUBTASKS	ACTIONS	RESULTS
a. Prepare <b>PLGR</b> for loading key	(1) Turn PLGR ON	N/A
	(2) Observe PLGR perform its self-test	N/A
	(3) Note when this screen appears	<b>FIX</b> <b>FOM 5</b> 18Y <b>MGRS- New</b> <b>WK 82223e</b> <b>63528n</b> <b>EL-00027m</b> ↑/↓ <b>P</b>
	(4) Connect W4 to PLGR, but not to ANCD yet	N/A
b. Prepare <b>ANCD</b> for loading PLGR key	(1) Turn ANCD ON	select: Soi <b>Radio</b> supervisor
	(2) Enter RADIO	Send Receive Database sEtap <b>Comsec</b> Time
	(3) Enter COMSEC	vG <b>Ld</b> Rv Ak Mk vU
	(4) Enter LD	select: <b>TeK</b> Kek
	(5) Enter TEK, press PgDN and ENTR to select	<b>Select key</b> qUit (name/number)
	(6) Press PgUP/PgDN to view, ENTR to select	Select key <b>qUit</b> (PLGR key name)                    XMT
	(7) Enter QUIT	Connect ANCD to RT <b>(WAIT)*</b> [↓]

SUBTASKS	ACTIONS	RESULTS
<b>c. Transfer PLGR key from ANCD to PLGR</b>	(1) Press ↓ ( <b>Do not</b> connect ANCD to RT)*	Press [LOAD] on RT**
	(2) Now connect W4 to ANCD	Key loaded

\* Do not connect W4 to ANCD until directed to do so by the ACTIONS column. Sequence of task requires that you connect W4 to PLGR, then select key to be transferred, and then connect W4 to ANCD. When you connect to W4 to the ANCD, the PLGR key is immediately transferred.

\*\* Ignore this reference to the RT; only the ANCD and PLGR are involved in this task

### **7.3. SECURE TELEPHONE UNIT (STU) TASKS**

#### **7.3a. Definition of STU Tasks**

**WHAT ARE THEY?**

There are four STU tasks which enable an NCS or communications specialist to transfer classified data over unlimited distances via commercial or military telephone circuits.

**WHAT' S INVOLVED?**

COMSEC keys, FH data (hopsets, TSK, and net IDs), and SOI information can be sent from ANCD to ANCD via a STU transfer.

**WHAT' S REQUIRED?**

It is assumed that the NCS or communications specialist performing these tasks is fully qualified in the employment of the STU for sending and receiving classified information. Only the four tasks shown below, involving use of the ANCD with the STU, represent required training.

#### **7.3b. Summary of STU Tasks**

**STU TASK 1:**

**Send COMSEC Keys/FH Data From ANCD to ANCD Via STU**

This task allows an NCS or communications specialist to send classified COMSEC keys and FH data from an ANCD at one location to an ANCD at another location, regardless of distance, by commercial or military telephone.

**STU TASK 2:**

**Receive COMSEC Keys/FH Data Into An ANCD Via STU**

This task enables an NCS or communications specialist to receive and store in an ANCD the COMSEC keys and FH data sent from another ANCD by telephone.

**STU TASK 3:**

**Send SOI Information From ANCD to ANCD Via STU**

This task permits an NCS or communications specialist to transmit classified SOI information from an ANCD at one location to an ANCD at another location by telephone.

**STU TASK 4:**

**Receive SOI Information Into An ANCD Via STU**

This task allows an NCS or communications specialist to receive and store in an ANCD that classified SOI information sent from one location to another by telephone.

**7.3c. Send COMSEC Keys/FH Data From ANCD to ANCD via STU (STU Task 1)**

**DESCRIPTION**

This task allow an NCS or communications specialist to send classified COMSEC keys (TEK and KEK) and FH data (hopsets, TSK, Net IDs) from an ANCD at one location to one at another location, regardless of distance, via commercial or military telephone circuits.

**DETAILED FLOWCHARTS**

**SEND COMSEC KEYS/FH DATA FROM ANCD TO ANCD VIA STU**

SUBTASKS	ACTIONS	RESULTS
a. Coordinate transfer by STU	(1) Contact receiver	N/A
	(2) Coordinate transfer preparations	Proper STU keys; 2400 BPS; PT/CT voice checked
b. Prepare ANCD for STU transfer	(1) Turn ANCD ON	select: Soi <b>Radio</b> Supervisor
	(2) Enter RADIO	<b>Send</b> Receive Database sEtop COMSEC Time
	(3) Enter SEND	send to: Radio Ancd <b>Stu Pc</b>
	(4) Enter STU	Loadset* Database* Time** Key* Eset* Mwod***
	(5) Enter Loadset/Database or Eset as desired	System high is (U)/(C)/(S)/(TS) [↓]
c. Select data to send	(1) Press 1, then PgUp/PgDN to view item	select: Loadset (example) 99INDIVA.LST (DI)
	(2) Press ENTR to select data item	Connect to STU and press [SEND] ( <b>WAIT</b> )****
d. Send data by STU transfer	(1) Ensure receiving station is ready for you to send	(Both STUs must be placed in secure data mode)
	(2) Press SEND	Sending final data/ Transfer successful [↓]

\* Loadset, database, key, or Eset may be selected for STU transfer.

\*\* Time cannot be transferred by STU.

\*\*\* The term "MWOD" (multiple word of day) is used in loading procedure for the Have Quick radio found in selected aircraft.

\*\*\*\* Do not press SEND until receiving station is ready to press RCV; see STU Task 2 for details.

**7.3d. Receive COMSEC Keys/FH Data Into ANCD via STU (STU Task 2)**

**DESCRIPTION**

This task enables an NCS or communications specialist to receive and store in an ANCD, those COMSEC keys and FH data, classified or unclassified, sent from another location via STU over telephone lines.

**DETAILED FLOWCHART**

**RECEIVE COMSEC KEYS/FH DATA INTO ANCD VIA STU**

SUBTASKS	ACTIONS	RESULTS
a. Coordinate STU transfer	(1) Receive initial call from sending station	N/A
	(2) Coordinate STU transfer preparations	(Proper STU keys; 2400 BPS; PT/CT voice checked)
b. Prepare ANCD for STU transfer	(1) Turn ANCD ON	select: Soi <b>Radio</b> sUperVlsor
	(2) Enter RADIO	Send <b>Receive</b> Database sEtop Comsec Time
	(3) Enter RECEIVE	receive: Ancd Cfd <b>Stu</b> Pc Mx
	(4) Enter STU	Loadset* Database* Time** Key* Eset* Mwod***
	(5) Enter Loadset/Database/Key/Eset as desired	Connect to STU and press [RCV] <b>(WAIT)</b> ****
c. Receive COMSEC/FH data by STU transfer	(1) Ensure you are ready for sender to press [SEND]	N/A
	(2) Place your STU in secure data mode	N/A
	(3) Press [RCV] in coordination with STU sender	Receiving final data/ Transfer successful

\* **Loadset, database, key, or Eset may be selected for the STU transfer.**

\*\* **Time cannot be transferred by STU.**

\*\*\* **The term "MWOD" is used in loading the Have Quick radio found in selected aircraft.**

\*\*\*\* **Do not press [RCV] until sending station is ready to press [SEND].**

**7.3e. Send SOI information From ANCD to ANCD via STU (STU Task 3)**

**DESCRIPTION**

This task permits an NCS or communications specialist to transmit SOI information by telephone, classified or unclassified, from an ANCD at one location to an ANCD at another location. Proficiency of the sender and receiver in the employment of the STU is a prerequisite for performance of this and the following STU task

**DETAILED FLOWCHART**

**SEND SOI INFORMATION FROM ANCD TO ANCD VIA STU**

SUBTASKS	ACTIONS	RESULTS
a. Coordinate SOI transfer by STU	(1) Contact receiver	N/A
	(2) Coordinate STU transfer preparations	(Proper STU keys; 2400 BPS; PT/CT voice checked)
b. Prepare ANCD for STU transfer	(1) Turn ANCD ON	select: <u>Soi</u> Radio sUpervisor
	(2) Enter SOI	qRef Group Net sufX Pyro Tmpd <u>Set*</u> C/s Find Memo
	(3) Enter SET*	select: Choose <u>Send</u> Receive
	(4) Enter SEND	Scroll (↑/↓) & press ENTR to select Set [↓]



SUBTASKS	ACTIONS	RESULTS
<b>c. Select SOI data to send</b>	(1) Scroll to Identify set	Set: (name/number) Edn, (name/time period) [↓]
	(2) Press ENTR to select set	Do you want to transfer QREF? (Y/N)**
	(3) Enter YES or NO**	Do you want to specify groups to send? (Y/N)***
	(4) Enter YES or NO***	Do you want to specify a time pd to send? (Y/N)***
	(5) Enter YES or NO***	include Suffix & Smoke/Pyro data? (Y/N)***
	(6) Enter YES or NO***	send to: Ancd Pc Broadcast <u>Stu</u>
	(7) Enter STU	Connect to STU and press [SEND] <b>(WAIT)</b> ****
<b>d. Send SOI information by STU transfer</b>	(1) Ensure receiving station is ready for you to send	(Both STUs must be placed in secure data mode)
	(2) Press [SEND]	Processing. Please wait (shows % of bytes sent)
		Sending of SOI data is completed [↓]

\* *Set is selected only as an example.*

\*\* *Either full or selected data can be sent by STU transfer, but they must be sent one at a time.*

\*\*\* *Any SO/ item may be selected for STU transfer.*

\*\*\*\* **Do not press [SEND] until you ensure the receiving station is ready to receive.**

**7.3f. Receive SOI Information Into An ANCD via STU (STU Task 4)**

**DESCRIPTION**

This task allows an NCS or communications specialist to receive and store in an ANCD, that SOI information, classified or unclassified, sent from another station by STU.

**DETAILED FLOWCHART**

**RECEIVE SOI INFORMATION INTO ANCD VIA STU**

SUBTASKS	ACTIONS	RESULTS
a. Coordinate SOI transfer by STU	(1) Receive initial call from sending station	N/A
	(2) Coordinate STU transfer preparations	(Proper STU keys; 2400 BPS; PT/CT voice checked)
b. Prepare ANCD for STU transfer	(1) Turn ANCD ON	select: <b>Soi</b> Radio supervisor
	(2) Enter SOI	qRef Group Net sufX Pyro TmPd <b>Set*</b> C/s Find Memo
	(3) Enter SET	select: Choose Send <b>Receive</b>
	(4) Enter RECEIVE	receive from: Ancd Pc Broadcast <b>Stu</b>
	(5) Enter STU	Connect to STU and press [SEND] ( <b>WAIT</b> )**
c. Receive SOI data sent by STU transfer	(1) Ensure you are ready for sender to [SEND]	N/A
	(2) Place your STU in secure data mode	N/A
	(3) Press [RCV] when sender presses [SEND]	Processing. Please wait (shows of of bytes sent)
		Sending of SOI data is completed [↓]

\* Set is selected only as an example. Any SOI item may be selected for transfer by STU.

\*\* Do not press [RCV] until sending station is ready to press [SEND].

**7.4. FREQUENCY HOPPING MULTIPLEXER (FHMUX) TASKS**

**DESCRIPTION**

This task allows an NCS to establish radio priority strategy for up to four radios when FHMUX is employed.

**DETAILED FLOWCHART**

**NCS OPERATIONS WITH MULTIPLEXER**

SUBTASKS	ACTIONS	RESULTS
<p><b>a. SET: POWER ON</b></p>	<p>Set: POWER toggle switch to ON.</p>	<p>The POWER indicator should illuminate continuously and the four BIT/FAULT indicators should illuminate for approximately five seconds after power-on and then extinguish upon successful completion of the self test. The POWER ON indicator should stay illuminated.</p>
<p><b>b. SET: RADIO PRIORITY</b></p>	<p>Get: Net Priority strategy.</p> <p>Set: RADIO PRIORITY to EQUAL to give all RTs equal communications priority.</p> <p>OR</p> <p>Set: RADIO PRIORITY to desired RT, 1A thru 2B, to give highest priority to a single RT</p> <p>OR</p> <p>Set: RADIO PRIORITY to RXMT 1A+1B if RT 1A and RT 1B are in the retransmit mode and they are to have higher priority than RTs 2A and 2B.</p>	<p>N/A</p>

THIS PAGE INTENTIONALLY  
BLANK.

# CHAPTER 8

## OPERATOR MAINTENANCE

**IN THIS CHAPTER:**

<b>8.1</b>	<b>SINGGARS RADIO MAINTENANCE .....</b>	<b>8-1</b>
	a. General .....	8-1
	b. PMCS Guidance .....	8-3
	c. PMCS for SINGGARS Radios .....	8-4
	d. Operator Troubleshooting Guides .....	8-7
<b>8.2</b>	<b>ASSOCIATED EQUIPMENT, OPERATOR MAINTENANCE .....</b>	<b>8-13</b>
	a. PMCS for Control, Receiver-Transmitter (RCU) .....	8-13
	b. PMCS for Control-Monitor (C-M) .....	8-17
	c. Vehicular Intercom (VIC) .....	8-18
	d. Loudspeaker (LS-671) .....	8-20
	e. Automated Net Control Device (ANCD)(AN/CYZ-10) .....	8-21
	f. Precision Lightweight GPS Receiver (PLGR)(AN/PSN-11) .....	8-22
	g. Frequency Hopping Multiplexer (FHMUX) .....	8-23
	h. Handheld Remote Control Radio Device (HRCRD) .....	8-24
<b>8.3</b>	<b>BATTERY REQUIREMENTS .....</b>	<b>8-25</b>
	a. General .....	8-25
	b. Manpack Radio/RCU Main Power .....	8-25
	c. Manpack Radio/RCU Hold Up Battery (HUB) .....	8-26
	d. Automated Net Control Device (ANCD) Main Power .....	8-27
	e. Precision Lightweight GPS Receiver (PLGR) Main Power/HUB .....	8-28

### 8.1. SINGGARS RADIO MAINTENANCE

#### 8.1 a. General

**BY DESIGN**

Your SINGGARS radio was designed to be highly reliable and as free as possible of maintenance requirements, especially for the operator. Your SINGGARS radio requires no periodic maintenance services. Preventive Maintenance Checks and Services are required of the operator before, during, and after operations.

**DEFINITION**

Preventive Maintenance Checks and Services (PMCS) means systematic caring, inspecting, and servicing of equipment to keep it in good condition and prevent breakdowns.

## STANDARDS

The purpose of PMCS is to ensure that your SINCGARS radios and associated items of equipment meet Army maintenance standards, which are summarized here as:

- Equipment is fully mission capable, or;
- Corrective actions are being (or have been) taken, and;
- Required repairs are being made (or have been requested of the proper maintenance level), and;
- Required supplies and repair parts are on hand (or have been requisitioned).

## REQUIREMENTS

As a SINCGARS radio operator, you are expected to do the following:

- Perform prescribed PMCS “Before Operations” steps each time you place the radio into operation.
- Periodically perform PMCS “During Operations” steps while the radio is being operated.
- Perform prescribed PMCS “After Operations” steps once your use of the radio has been completed.
- If authorized and able to do so, correct all faults, deficiencies, or problems you find while performing PMCS.
- If unable to correct a problem identified by PMCS, report it to your unit maintenance personnel.
- Maintain a DA Form 2404 (Equipment Inspection and Maintenance Worksheet) on your radio as required by your unit SOP or applicable Army Regulations regarding The Army Maintenance Management System (TAMMS). (You do not need to record problems that you fix.)

**8.1 b. PMCS Guidance**

**ITEM NUMBER**

The numerical sequence of those parts, components, or functions of your radio configuration that the PMCS direct be checked. "Cables" is one example of a PMCS item.

**INTERVAL**

This column indicates when each check is to be made. For SINCGARS radio configurations, only Before, During, and After (Operations) apply.

**ITEM  
TO BE  
INSPECTED**

The parts, components, or functions of your radio that the PMCS table tells you to check. "Self-Test" is an example. Items are shown in the order they are to be performed and may be referred to be Item Number or Name, as desired.

**PROCEDURE**

The Procedure column advises you of the checks to be made and steps to be taken. These are to be performed in the order listed in the PMCS table.

**NOT MISSION  
CAPABLE IF:**

The term "Mission Capable" means that your radio is on hand and ready to perform its combat mission as pertains to the item being checked. Your radio is "Not Mission Capable" when fault shown in this column is encountered and you are unable to correct the problem. Wherever a check does not have an entry in this column, problems should be corrected if possible but do not make the radio not mission capable.

**OPERATOR' S  
MANUAL**

In performing your PMCS, it may be necessary, or at least helpful, to refer to the many graphics, task performance procedures, and explanations found elsewhere in this operator' s manual. Proper performance of PMCS steps requires that you have been trained as an operator, know how to make best use of your Manual and Pocket Guide, and have had at least some experience with the radio. Although these PMCS are not difficult to perform, they do require an understanding of operator tasks and procedures.







Item Nr	When	Item to Check/Service	Operator Procedure	Not Fully Mission Capable IF:
7	Before	<b>DATA LOADING:</b> SC Freq COMSEC key FH data Sync time	a. Load SC freq. b. Load COMSEC key. Load FH data. d. Load sync time*** (electronic or manual).	a. SC freq will not load. b. COMSEC key will not load. FH data will not load. d. Sync time will not load.
8	Before During After	<b>COMM CHECK:****</b> Voice/data SC mode FH mode Plain text Cipher text RXMT mode	a. Check for sidetone. b. Check voice comm in SC- PT and FH -CT (check SQ OFF while in SC mode). c. If data comm is mission-required, check data comm in FH -CT using mission-related data device.***** d. If RXMT is mission-required, check RXMT in all mission - related modes.	a. Sidetone is not heard. b. Cannot communicate in SC-PT or FH-CT, voice mode. c. Cannot communicate in mission-required data mode using mission-related data device. d. Cannot retransmit in mission-related modes.

\* "Does not function properly" means that a control will not do what it is intended to do, for example, turning the FCTN knob does not change the radio's function. it may be necessary to wait until item 8 (Communications Check) to determine for sure that some controls do or do not function properly.

\*\* "Damaged and cannot be used" means that after visual inspection or operational check you determine that a piece of equipment, for whatever reason, is faulty and will not support your mission requirements or presents a safety hazard.

\*\*\* Use of the ICOM fill procedure is appropriate here, but separate checks of COMSEC keys, FH data, and sync time elements are required.

\*\*\*\* Operators having special requirements (NCSs for example) should check those functions that are important to mission operations (ERF for example). Skip this step if unit SOP or the tactical situation prohibits transmitting.

\*\*\*\*\* Unless your mission is likely to require use of data mode or retransmission operations, you do not need to perform these two checks.

**8.1 d. Operator Troubleshooting Guides****RELIABILITY**

While the reliability of the SINCGARS radio has been thoroughly proven in tests and troop unit experience, an operator can expect to encounter some problems, especially when the radio and associated equipment are used together for various reasons.

**PROBLEMS**

Four problems are experienced most often. They are:

- Loading RT with COMSEC and FH data from ANCD fails
- Operator is unable to contact the net NCS
- Operator hears no traffic on the net.
- Radio presents strange message or noise that will not clear.

**CAUSES**

Any of these problems may be caused by an equipment failure. But, these problems can also be caused by operator error, improperly set controls, weak batteries, loose connections, or use of wrong data - - to cite a few reasons.

**TS GUIDES**

The Troubleshooting Guides which follow offer the operator systematic procedures for identifying and eliminating common faults, helping the operator to maintain communications.

**UNIT  
MAINTENANCE**

When there is an equipment failure, or when your use of these Troubleshooting Guides fails to solve the problem, contact your Unit Maintainer.

**OPERATOR TROUBLESHOOTING GUIDE 1**  
**Loading RT With COMSEC/FH Data From ANCD Fails**

STEPS	CHECKS	ACTIONS
1. Perform ICOM Fill Again	(1) Does ANCD indicate that data is being transferred?	YES: Go to Step 2 NO: Continue
	(2) Does RT indicate that data has been received?	YES: Problem is solved NO: Go to Step 2
2. Verify ANCD Data Storage	Does ANCD contain a loadset?	YES: Continue NO: Load/replace ANCD,* cont
3. Ensure ANCD is Functional	(1) Is low battery light on?	YES: Replace btry, cont NO: Replace ANCD*, cont
	(2) Does ICOM fill now load RT?	YES: Problem is solved NO: Go to Step 4
4. Ensure Fill Cable is Serviceable	(1) Is cable damaged, cut, or broken?	NO: Continue YES: Replace cable*, cont
	(2) Is fill cable properly connected to ANCD & RT?	YES: Continue NO: Reconnect, cont
	(3) Does ICOM fill now load RT?	YES: Problem is solved NO: Go to Step 5
5. Re-run SINCGARS Radio PMCS	(1) Does RT pass all checks and tests?	YES: Continue NO: See Unit Maintenance
	(2) Does ICOM fill now load RT?	YES: Problem is solved NO: See Unit Maintenance

\* Where ACTION is to “replace” ANCD and fill cable, it is anticipated that the operator will borrow such item for the purpose of troubleshooting. If borrowing is not feasible, it will be necessary for the operator to contact Unit Maintenance to obtain a substitute item or get assistance with the problem.

## OPERATOR TROUBLESHOOTING GUIDE 2

### Operator is Unable to Contact the Net NCS\*

STEPS	CHECKS	ACTIONS
1. Verify Correct RT Control Settings	(1) Is FCTN switch set to SQ ON?	YES: Continue NO: Go to SQ ON, cont
	(2) Is CHAN switch set to net operational channel?	YES: Continue NO: Change CHAN, cont
	(3) Is COMSEC set to CT? (or PT if in use?)	YES: Continue NO: Reset COMSEC, cont
	(4) Is MODE set to FH? (or SC if in use?)	YES: Continue NO: Change MODE, cont
	(5) Is RF PWR set properly for NCS location?	YES: Continue NO: Change RF PWR, cont
	(6) Is VOL set to hear NCS or net traffic?	YES: Go to Step 2 NO: Reset VOL, go to Step 2
2. Verify Correct COMSEC Key is Loaded	(1) Is TEK loaded in operational channel?	YES: Continue NO: Reload/scroll TEK, cont
	(2) Can NCS now be contacted?	YES: Problem is solved NO: Go to Step 3
3. Verify Correct Net ID is Used	(1) Is correct Net ID loaded in operational channel?	YES: Continue NO: Reload FH data, cont
	(2) Can NCS now be contacted?	YES: Problem is solved NO: Go to Step 4
4. Verify Correct GPS Sync Time is Used**	(1) Are ANCD and RT times within +/- 2 seconds?	YES: Continue NO: Use passive LNE***, cont
	(2) Can NCS now be contacted?	YES: Problem is solved NO: Go to Step 5
5. Re-run SINCGARS Radio PMCS	(1) Does RT pass all checks and tests?	YES: Continue NO: See Unit Maintenance
	(2) Can NCS now be contacted?	YES: Problem is solved NO: See Unit Maintenance

\* If other traffic can be heard on the net, problem is assumed to rest with the NCS station.

\*\* ANCD time may not be valid if it has been more than 24 hours since ICOM fill of radio.

\*\*\* Passive late net entry (LNE).

### OPERATOR TROUBLESHOOTING GUIDE 3

#### Operator Hears No Traffic on the Net

STEPS	CHECKS	ACTIONS
1. Perform Passive Late Net Entry (LNE)	(1) Does RT display show " LF Xxx" ?	YES: Wait for traffic on net, cont NO: Adjust DIM switch, cont
	(2) Is traffic heard and "L" dropped from RT display?	YES: Problem is solved NO: Go to Step 2
2. Check VOL Control Setting	(1) Is VOL set high enough to hear traffic?	YES: Go to Step 3 NO: Adjust VOL, cont
	(2) Is traffic now heard?	YES: Problem is solved NO: Go to Step 3
3. Ensure That Handset, Headset, LS is Working	(1) Is handset, headset, LS operational?	YES: Go to Step 4 NO: Replace item, cont
	(2) Is traffic now heard?	YES: Problem is solved NO: Go to Step 4
4. Verify Sync Time*	(1) Are ANCD and RT times within +/- 2 seconds?	YES: Go to Step 5 NO: Reload sync time, cont
	(2) Is traffic now heard?	YES: Problem is solved NO: Go to Step 5
5. Verify FH Data	(1) Is there FH data loaded in the operational channel?	YES: Continue NO: Reload RT, cont
	(2) Is traffic now heard?	YES: Problem is solved NO: Continue
	(3) Is correct Net ID loaded in operational channel?	YES: Go to Step 6 NO: Change net ID, cont
	(4) Is traffic now heard?	YES: Problem is solved NO: Go to Step 6
6. Manpack Only** - Check Main Battery	(1) Does main battery need to bechanged?	YES: Replace battery, cont NO: Go to Step 7
	(2) Is traffic now heard?	YES: Problem is solved NO: Go to Step 7

STEPS	CHECKS	ACTIONS
7. Perform Hot Start Net Entry***	(1) Do COMSEC/FH data load in RT?	YES: Continue NO: Go to TS Guide 1
	(2) Is traffic now heard?	YES: Problem is solved NO: Continue****
	(3) Can NCS be contacted?	YES: Problem is solved NO: See Unit Maintenance

\* ANCD time may not be valid if it has been more than 24 hours since ICOM fill of radio.

• □ For vehicular radios, skip this step and continue with Step 7. Battery power can be checked by placing RF PWR in HI and pressing PTT. Signal display of 2 or less indicates your battery is weak.

\*\*\* Operator has option of using CUE and ERF method of late net entry in lieu of the Hot Start procedure if desired.

\*\*\*\* The possibility that there is no traffic on the net must be considered, so try to contact your NCS to check serviceability of your radio.

## OPERATOR TROUBLESHOOTING GUIDE 4

### Radio Presents Strange Message or Noise That Will Not Clear

STEPS	CHECKS	ACTIONS
1. Set FCTN to STBY, then back to SQ ON	Does message/noise clear?	YES: Problem is solved NO: Go to Step 2
2. Set FCTN to Z-FH*	Does display show "GOOD" ?	YES: Go to Step 3 NO: See Unit Maintenance
3. Set FCTN to OFF, wait 10 set, then back to Z-FH	Does display now show "GOOD" ?	YES: Go to Step 4 NO: See Unit Maintenance
4. Run RT Self-Test	Does self-test result in display showing "GOOD" ?	YES: Go to Step 5 NO: See Unit Maintenance
5. Perform ICOM Fill and Re- enter Net	Has message/noise cleared? **	YES: Problem is solved NO: See Unit Maintenance

\* Do not perform Steps 2 thru 5 unless the nature of your mission will permit you to be out of the net for a short period.

\*\* Steps 2 thru 5 are the equivalent of "re-booting" your radio. In that the SINCGARS radio is basically a computer, this procedure frequently works when other efforts to clear a strange message or noise do not.



## 0.2. ASSOCIATED EQUIPMENT

### SCOPE

This paragraph of your SINCGARS Operator's Manual briefly addresses the maintenance requirements of those items of equipment most often used in conjunction with your radio. The intent of this paragraph is to give you a summary of operator maintenance tasks and provide appropriate references from which more detailed information may be obtained.

## 8.2a. PMCS for Control, Receiver-Transmitter (RCU)

### DIFFERENCES

Major differences between the SINCGARS RT and RCU are these:

- RCU does not accept FH data; uses that data loaded into the companion RT
- RCU has speaker connection and switch in lieu of RT RXMT and ANT connectors.
- RCU FCTN switch has an intercom (ICM) position in lieu of the RT remote (REM) position.
- RCU SIG display lights when companion RT receives a signal.
- RCU [BATT] key on first press provides RCU battery life Indication, on second press provides RT battery life indication.
- If two-wire connecting RCU with RT is cut or disconnected (or RT FCTN is not set to REM), RCU display shows "OPEN."

**PREVENTIVE MAINTENANCE CHECKS AND SERVICES FOR**

**SINGGARS REMOTE CONTROL UNIT (RCU)**

(Control, Receiver-Transmitter, C- 11561 (C)/U)

Item Nr.	When	Item to Check/Service	Operator Procedure	Not Fully Mission Capable If:
1	Before During After	<b>CONTROLS:</b> SPKR RF PWR CHAN MODE FCTN DIM COMSEC VOL	<ul style="list-style-type: none"> <li>a. Check for cracked or broken controls.</li> <li>b. Check for loose controls.</li> <li>c. Check for frozen controls.</li> <li>d. Check for missing control knobs.</li> </ul>	<ul style="list-style-type: none"> <li>a. Broken control does not function.*</li> <li>b. Loose control does not function.*</li> <li>c. Frozen control does not function.*</li> <li>d. Knob missing and control does not function.*</li> </ul>
2	Before During After	<b>CABLES:</b> Audio/Data (W4) Field Wire (WD1)	<ul style="list-style-type: none"> <li>a. Check for missing cable or field wire.</li> <li>b. Check for proper installation of cable and field wire.</li> <li>c. Check for tightness of connectors.</li> <li>d. Check for obvious damage to cable or field wire.</li> </ul>	<ul style="list-style-type: none"> <li>a. Cable or field wire is missing.</li> <li>d. Cable or field wire is damaged and cannot be used**</li> </ul>
3	Before	<b>POWER:</b> Manpack  Vehicular  RCU	<ul style="list-style-type: none"> <li>a. Check for presence of RCU main battery.</li> <li>b. Check vehicle power availability.</li> <li>c. Move COMSEC from Z to PT, properly adjust DIM, move FCTN from OFF to Z-FH; and check that RCU display lights.</li> </ul>	<ul style="list-style-type: none"> <li>a. Main battery is missing; cannot be replaced.</li> <li>b. No vehicle power; cannot be corrected.</li> <li>c. RCU display does not light.</li> </ul>
4	Before	<b>SELF -TEST:</b> [Connect RCU to RT and set RT FCTN to REM)	<ul style="list-style-type: none"> <li>a. With RCU FCTN in Z-FH, check that RCU display shows "GOOD."</li> <li>b. Move RCU COMSEC to CT and check that alarm will clear.</li> <li>c. Move RCU FCTN to TST and check that RCU display shows "GOOD" at end.</li> </ul>	<ul style="list-style-type: none"> <li>a. RT display does not show "GOOD."</li> <li>b. COMSEC alarm will not clear.</li> <li>c. Self-test ends with other than "GOOD."</li> </ul>

Item Nr.	When	item to Check/Service	Operator Procedure	Not Fully Mission Capable If:
5	Before	<b>KEYPAD:</b> (Numbers 0-9)	With RCU set to CT, SC, LD, and channel shown:: a. Press <b>FREQ, CLR,</b> and enter: CUE:           31000 MAN:           32000 CHAN 1:       43000 CHAN 2:       54000 CHAN 3:       65000 CHAN 4:       76000 CHAN 5:       87000 CHAN 6:       87975 b. Press <b>STO</b> for each entry.	a. Any test frequency (0-9) cannot be entered.  b. Any test frequency (0-9) cannot be stored.
6	Before	<b>DATA LOADING:</b> SC Frequencies COMSEC Keys	a. Load SC frequencies  b. Load COMSEC keys***	a. SC frequency will not load in RCU. b. COMSEC key will not load in RCU.

Item Nr.	When	Item to Check/Service	Operator Procedure	Not Fully Mission Capable If:
7	Before During After	<b>COMM CHECK:</b> SC Mode FH Mode Plain Text Cipher Text Voice Data	a. Check for sidetone. b. Check ability to change RT channel from RCU. c. Check voice comm in SC-PT and FH-CT**** (Check SQ OFF while in SC mode). d. If data comm is mission-required, check data comm in FH-CT, using mission-related data device.**** e. Check intercomm capability between RCU and radio.	a. Sidetone is not heard. b. Cannot change RT channel from RCU c. Cannot communicate in SC-PT/FH-CT voice mode from RCU. d. Cannot communicate in mission-required data mode using mission-related data device.

\* “Does not function properly” means that a control will not do what it is intended to do, for example, turning the FCTN knob does not change the radio’s function. It may be necessary to wait until Item 7 (Communications Checks) to determine for sure that some controls do or do not function properly.

\*\* “Damaged and cannot be used” means that after visual inspection or operational check you determine that a piece of equipment, for whatever reason, is faulty and will not support your mission requirements or presents a safety hazard.

\*\*\* Use of the ICOM fill procedure is appropriate here, but only COMSEC keys are loaded into the RCU.

\*\*\*\* Skip steps “c” and “d” if unit SOP or tactical situation prohibits transmitting.

\*\*\*\*\* Unless your mission is likely to require use of data mode, you do not need to perform this check.

**8.2b. PMCS for Control-Monitor (C-M)**

**PREVENTIVE MAINTENANCE CHECKS AND SERVICES FOR  
SINGGARS CONTROL-MONITOR**

(Control-Monitor (C-M), C-11291/VRC Series)

<b>Item Nr.</b>	<b>When</b>	<b>Item to Check/Service</b>	<b>Operator Procedure</b>	<b>Not Fully Mission Capable If:*</b>
1	Before During After	CONTROLS: RADIO FCTN INIT DIM	a. Check for cracked or broken controls. b. Check for loose controls. c. Check for frozen controls. d. Check for missing control knobs.	
2	Before During After	CABLES: C-M Cable (CX-13290)	a. Check for presence. b. Check for proper installation of cable. c. Check for tightness of connectors. d. Check for obvious damage to cable.	
3	Before	SELF-TEST:	a. Perform C-M self-test. b. Test should result in "Gd."	
4	Before	CONTROL OF RT FUNCTIONS:	a. Check control of RF PWR. b. Check control of RT Mode. c. Check control of Channel. d. Check control of COMSEC.	

\* *The Control-Monitor is not essential to the operation of the SINGGARS radio with which it is used. Problems found with the Control-Monitor during PMCS are corrected or reported to Unit Maintenance, but they do not result in Not Fully Mission Capable determinations.*

**8.2c. Vehicular Intercommunication Set (WC) (AN/WC-1)**

<b>OPERATOR</b>	Operator level preventive maintenance requirements and PMCS for the VIC are covered in Chapter 3, TM 11-5830-340-12, Operator's and Organizational Maintenance Manual, Intercommunication Set, AN/VIC-1.
<b>UNIT MAINTENANCE</b>	Unit level preventive maintenance requirements and PMCS for the VIC are covered in Chapter 5, TM 11-5830-340-12, Operator's and Organizational Maintenance Manual, Intercommunication Set, AN/VIC-1. Unit level maintenance procedures for the VIC are also addressed in TM 11-5820-890-20-2, Unit Maintenance Manual, SINCGARS Ground ICOM Radio Sets.
<b>VIC PMCS</b>	Preventive Maintenance Checks and Services for the VIC system are shown below for the convenience of the SINCGARS operator using a VIC intercomm. For answers to technical questions concerning the VIC system, see the VIC manual cited above (TM 11-5830-340-12).
<b>NMC STATUS</b>	Radios in VIC-1 equipped vehicles can be operated directly, by-passing the VIC system if necessary. Intercom, however, is essential for the safe and effective operation of the combat vehicle. Thus, intercom is a Not Fully Mission Capable deficiency.

**PREVENTIVE MAINTENANCE CHECKS AND SERVICES FOR**  
**SINGGARS RADIOS USED WITH INTERCOMMUNICATIONS SET**  
**(AN/VIC-1)**

<b>item Nr.</b>	<b>When</b>	<b>Item to Check/Service</b>	<b>Operator Procedure</b>	<b>Not Fully Mission Capable If:</b>
1	Before During After	<b>CONTROLS:</b> MAIN PWR POWER ON/OFF INT ACCENT RADIO TRANS MONITOR SWITCHES	<ul style="list-style-type: none"> <li>a. Check for cracked or broken controls.</li> <li>b. Check for loose controls.</li> <li>c. Check for frozen controls.</li> <li>d. Check for missing control knobs.</li> </ul>	
2	Before During After	<b>CABLES:</b>	<ul style="list-style-type: none"> <li>a. Check for missing cables.</li> <li>b. Check for proper installation of cables.</li> <li>c. Check for tightness of connectors.</li> <li>d. Check for obvious damage to cables.</li> </ul>	
3	Before	<b>POWER:</b>	<ul style="list-style-type: none"> <li>a. Ensure VAA CB1 is ON.</li> <li>b. Ensure VIC AM - 1780 circuit breaker is ON.</li> <li>c. Turn Power Switch to NORM.</li> <li>d. Power lamp should light.</li> </ul>	
4	Before During After	<b>COMM CHECK:</b> Intercomm Radio "A" Radio "B"	<ul style="list-style-type: none"> <li>a. Check ability to talk on Intercom from all crew control boxes at ALL, INT ONLY, and A; CDR only at position C.</li> <li>b. Check ability to talk and listen to Radio "A" from all crew control boxes at ALL and A.</li> <li>c. Check ability to listen to Radio "B" from all crew control boxes at ALL and C.</li> </ul>	<ul style="list-style-type: none"> <li>a. Intercom does not function*</li> </ul>

\* Although the SINGGARS radios of a combat vehicle equipped with the VIC intercom system can operate without the VIC, many combat vehicles require the operational use of the intercom for internal vehicle command and control. Whether your VIC system being inoperative constitutes a Non -Mission Ready status will vary with combat vehicle type.

**8.2d. Loudspeaker (LS-671)**

**PREVENTIVE MAINTENANCE CHECKS AND SERVICES FOR LOUDSPEAKER (LS-671)**

Item Nr.	When	Item to Check/Service	Operator Procedure	Not Fully Mission Capable If:*
1	Before During After	<b>CONTROLS:</b>  POWER SWITCH VOLUME CONTROL	a. Check for cracked or broken controls. b. Check for loose controls. c. Check for frozen controls. d. Check for missing controls.	
2	Before During After	<b>CABLE:</b> LS-671 Cable (CX - 13292)	a. Check for presence. b. Check for proper installation of cable. c. Check for tightness of connectors. d. Check for obvious damage to cable.	
3	Before	<b>POWER:</b>  CB1 (VAA) LS-671 Power Switch LS-671 Power Indicator Lamp	a. Turn LS-671 Power Switch to ON. b. Turn VAA CB1 to ON. c. Check that VAA DS1 lights. d. Check that LS-671 Power Indicator Lamp lights.	
4	Before	<b>LS-671 CONTROL OF RT:</b>  RT OFF/ON Loudspeaker Volume Handset Volume	a. Check ability to turn RT OFF/ON from LS-671. b. Check control of LS-671 volume. c. Check control of handset volume when connected to LS - 671.	

\* The Loudspeaker LS-671 is not essential to the operation of the SINGARS radio with which it is used. Problems found with the LS-671 during PMCS are corrected or reported to Unit Maintenance, but they do not result in Not Fully Mission Capable determinations.



## 8.2e. Automated Net Control Device (ANCD) (AN/CYZ- 10)

### MAINTENANCE CONCEPT

The maintenance concept for the ANCD is for the unit level maintainer to requisition and repair all external parts in accordance with TM 11-5810-394-14&P. If the problem is internal, Unit Maintenance personnel will use BIT software to determine the operational status of the ANCD. If the BIT confirms that the ANCD is faulty, the unit will turn in the faulty ANCD through normal supply channels to the COMSEC depot. The unit will then requisition a replacement ANCD through normal supply channels. Also, replacement ANCDs are normally available at brigade and higher level Signal Offices for temporary loan to units needing replacement ANCDs. Unit SOP should indicate how temporary replacement ANCDs are to be provided to subordinate units.

### OPERATOR MAINTENANCE

ANCD operator maintenance tasks are:

- Check for frayed cables, loose nuts or screws, correct seating of connectors, and completeness of equipment, whenever required.
- Clean the display window and keypad as necessary for clarity.
- Replace the battery on an as required basis when prompted by the ANCD LOW BAT message.

### BATTERY REPLACEMENT PROCEDURE

- |     |  |
|-----|--|
| (1) | Using a coin or screwdriver, remove four screws and battery compartment cover from ANCD. |
| (2) | Remove the battery housing from the ANCD.  |
| (3) | Remove batteries from the battery housing and replace them, maintaining proper polarity. |
| (4) | Insert the battery housing into the ANCD, again ensuring proper polarity.                |
| (5) | Install the battery cover and tighten screws to a firm setting.                          |
| (6) | Turn the ANCD ON and verify that your battery change was successful.                     |

Figure 9-1. ANCD Battery Replacement

**REQUIREMENT**

All ANCD users, including operators, are required to change ANCD battery/batteries whenever change is needed. Batteries should be changed as soon as feasible after the LOW BAT message appears in the ANCD display window.

**PROTECTING  
STORED DATA**

The ANCD will retain stored data for two minutes after the batteries have been removed. This gives you plenty of time to replace the spent batteries with new ones without risk of losing your stored data.

**IF STORED DATA  
IS LOST**

If you lose your data while replacing batteries, you will need to have the internal ANCD software reactivated. Should you experience this situation, take your ANCD to your unit maintainer for reactivation and reloading.

**REFERENCES**

TB 11-5820-890-12, Operator and Unit Maintenance for AN/CYZ-10, Automated Net Control Device (ANCD).

TM 11-5810-394-14&P Operator's; Unit, Direct Support, and Specialized Repair Activity Maintenance Manual with Repair Parts and Special Tools List for Automated Net Control Device.

**8.2f. Precision Lightweight GPS Receiver (PLGR) (AN/PSN-11)**

**OPERATOR MAINTENANCE**

The replacement of main power and hold-up batteries is the primary operator requirement in PLGR maintenance.

**REFERENCE**

TM 11-5825-291 -13, Operations and Maintenance Manual, Satellite Signal Navigation Set, AN/PSN-11

**8.2g. Frequency Hopping Multiplexer (FHMUX)**

**PREVENTIVE MAINTENANCE CHECKS AND SERVICES (PMCS)**

<b>Item Nr.</b>	<b>When</b>	<b>Item to Check/Service</b>	<b>Operator Procedure</b>	<b>Not Fully Mission Capable If:</b>
1	Before	<b>CONTROLS:</b>  POWER SWITCH	a. <b>Place the POWER toggle switch to the ON position</b> and verify POWER ON indicator is illuminated.  b. <b>Watch the POWER indicator and the four BIT/FAULT indicators.</b> The POWER should illuminate continuously and the four BIT/FAULT indicators should illuminate for approximately five seconds after power-on and then extinguish upon successful completion of the self test. The POWER ON indicator should stay illuminated.	The POWER ON indicator does not illuminate and stay illuminated  OR  any of the four BIT/FAULT indicators does not illuminate then extinguish after five seconds.

**FHMUX TROUBLESHOOTING PROCEDURES**

<b>STEPS</b>	<b>CHECKS</b>	<b>ACTIONS</b>
1. Verify Power On/Bit	1. Place the POWER toggle switch into the ON position and verify POWER ON indicator is illuminated.	YES: Continue NO: Contact Maintenance
	2. Verify that the four BIT/FAULT indicators illuminate for approximately five seconds and then extinguish after power up. The POWER ON indicator should stay illuminated.	YES: Continue NO: (a) Make note of the BIT/FAULT Indicators that are illuminated.  (b) Inform unit maintenance of the failure including the status of the BIT/FAULT indicators noted above.

**8.2h. Handheld Remote Control Radio Device (HRCRD)**

**PREVENTIVE MAINTENANCE CHECKS AND SERVICES (PMCS)**

Item Nr.	When	Item to Check/Service	Operator Procedure	Not Fully Mission Capable If:*
1	Before During After	<b>CONTROLS:</b>  <b>LIGHT:</b>  <b>VOLUME:</b>	<p>To control radio function, press [SEL] until required function is highlighted (CHAN; COMSEC; RF POWER; MODE). Then press the [DOWN ARROW] until specific item you need appears in the display.</p> <p>To turn backlight on, press the light button. To turn the light off, press the light button a second time.</p> <p>To change the level of audio volume, rotate the volume control knob on the side of the HRCRD to reach desired level.</p>	<p>The POWER ON indicator does not illuminate and stay illuminated</p> <p>OR</p> <p>any of the four BIT/FAULT indicators does not illuminate then extinguish after five seconds.</p>
2	Before During After	<b>CABLE:</b>	<ul style="list-style-type: none"> <li>a. Check for proper installation.</li> <li>b. Check for tightness of connectors.</li> <li>c. Check for obvious damage to cable.</li> </ul>	
3	Before During After	<b>CONNECTORS:</b>	<ul style="list-style-type: none"> <li>a. Check for obvious damage to connectors.</li> <li>b. Check for missing O-rings.</li> <li>a. Check for bent/broken pins.</li> </ul>	
4	Before During After	<b>COMM CHECK</b>	<ul style="list-style-type: none"> <li>a. Check for sidetone.</li> <li>b. Check voice comm.</li> </ul>	<ul style="list-style-type: none"> <li>a. Cannot transmit or receive.</li> </ul>

\* HRCRD is MISSION CAPABLE AS LONG AS TRANSMIT AND RECEIVE FUNCTIONS ARE OPERABLE. If controls are not functioning, place radio function switch to normal operating position (SO ON)/(LD) and change functions via keypads/swithces.

**8.3. BATTERY REQUIREMENTS**

**8.3a. General**

**POWER SOURCE** Manpack radios, RCUs, ANCDs, and PLGRs all depend upon batteries for their main power source. Manpack and vehicular radios, RCUs, and PLGRs depend upon hold up batteries (HUB) for retention of stored data when main power is interrupted.

**PURPOSE** The objective of this paragraph is to offer users of SINCGARS radios and associated equipment general guides regarding the number of hours of a particular type usage each battery is expected to provide.

**CAUTION** It is important to understand that the times presented are the result of computations as well as experience. Hours of service will vary depending upon how long the battery was in storage prior to use, temperature when being used, and other factors which cannot be clearly defined. Even so, these times offer the using unit a basis for planning battery requirements.

**SCOPE** Approximate length of expected service is stated for each item and version of equipment, using the proper battery for each item.

**8.3b. Manpack Radio/RCU Main Power**

**MAIN POWER** Main power batteries used in the manpack radio and RCU are:

- Battery, Non-Rechargeable (Lithium) (BA-5590/U)
- Battery, Rechargeable (BB590/U)
- Battery, Rechargeable (BB390/U)

*(Note: The BB390A/U requires the following items for recharging, PP8444A/U universal portable charger and a BB-390 adapter (J-6358/P). A 24 volt vehicular cable is available for the PP-8444A/U. See AAL for NSN's. Only the Non-Rechargeable BA - 5590 is used in the following charts.)*

**MANPACK BATTERY**

**MANPACK RADIO MAIN POWER**

(BA-5590: Approximate Length of Expected Service; RF PWR in HI)

<b>VOICE/DATA; FH &amp; CT</b>	<b>RT-1523</b>	<b>RT-1523A/D</b>	<b>RT-1523B/C</b>	<b>RT-1523E</b>
Normal (OPR)*	18 Hr	30 Hr	26 Hr	33 Hr
Heavy (NCS)**	11 Hr	18 Hr	15 Hr	TBD
Standby (STBY)	3+ Mon	3+ Mon	3+ Mon	3+ Mon

\* Operator usage rate is defined as 9 minutes of receiving/monitoring to every 1 minute of transmitting, on average.

\*\* NCS usage rate is defined as 2 minutes of receiving/monitoring to every 1 minute of transmitting, on average.

**RCU  
BATTERY**

**RCU MAIN POWER**

(BA-5590: Approximate Length of Expected Service; RF PWR in HI)

<b>VOICE/DATA; FH &amp; CT</b>	<b>RCU</b>
Normal (OPR)*	48 Hr
Heavy (NCS)**	40 Hr
Standby (STBY)	3+ Mon

\* Operator usage rate is defined as 9 minutes of receiving/monitoring to every 1 minute of transmitting, on average.

\*\* NCS usage rate is defined as 2 minutes of receiving/monitoring to every 1 minute of transmitting, on average.

**8.3c. Manpack Radio/RCU Hold Up Battery (HUB)**

**HUB**

Hold-up battery used is:

- Battery, Non-Rechargeable (BA-5372/U)

**BATTERY**

**MANPACK RADIO/RCU HUB BATTERY**

(BA-5372: Approximate Length of Expected Service)

<b>TYPE OF USE</b>	<b>RT- 1523 Series</b>	<b>RCU</b>
Normal Back Up	6+ Mon	6+ Mon

**CAUTION**

**SINGARS HUB and ANCD batteries look similar and can be physically interchanged. The HUB battery is 6.5 Volts while ANCD batteries are 3 Volts each. If HUB batteries (3 of them) are mistakenly placed in the ANCD, it will be destroyed. Placing one ANCD battery in the RT HUB position will cause the RT to lose its fill of data. Therefore, be sure you know which battery goes where. Always read the label before installing either HUB or ANCD batteries!**

**8.3d. Automated Net Control Device (ANCD) Main Power**

**ANCD MAIN POWER**

Batteries used are:

3 Duracel (3 Volt) (BA-5123/U)\*

**BATTERY LIFE**

**ANCD MAIN POWER (Requires 3 Batteries)**

(BA-5123: Approximate Length of Expected Service)

<b>TYPE OF USE</b>	<b>ANCD</b>
NORMAL (primarily SOI references)	30 Hr
HEAVY (NCS-frequent data transfers)	10 Hr
LOADED in OFF position	2+ Mon

\* *Use of Alkaline batteries in the ANCD may cause damage to the equipment and is strongly discouraged.*

**8.3e. Precision Lightweight GPS Receiver (PLGR) Main Power/HUB**

**PLGR BATTERIES**

Batteries used are:

- Lithium, Non-rechargeable (BA-5800/U)
- Nickel Cadmium, Rechargeable (Rockwell #221-0134-010)
- AA Alkaline (8), Non-rechargeable (WB101)
- AA Lithium (8), Non-rechargeable (L-91)
- Lithium, Non-rechargeable (HUB) (LS6 BA) (HUB)

**MAIN/HUB BATTERIES**

**PLGR MAIN POWER AND HUB BATTERIES**

(Approximate Length of Expected Service)

<b>TYPE OF USE</b>	<b>BA-5800</b>	<b>NiCad</b>	<b>WB101</b>	<b>L-91</b>	<b>LSGBA*</b>
Sync Time only**	48 Hr	7 Hr	9 Hr	19 Hr	1 year
Automatic Standby (Continuous)	10 Hr	2 Hr	2 Hr	4 Hr	1 year

\* *This is the HUB battery*

\*\* *PLGR is used as a source of SINCGARS sync time, to include electronic loading of RT when required. PLGR is not used for navigation in this computation.*



## APPENDIX A

### REFERENCES

#### A.1. **SCOPE**

This appendix lists all forms, field manuals, technical manuals, and miscellaneous publication references in this manual.

#### A.2. **FORMS**

DA Form 2028

Recommended Changes to Publications and Blank Forms.

DA Form 2028-2

Recommended Changes to Equipment Technical Publications

SF 361

Transportation Discrepancy Report (TDR).

SF 364

Report of Discrepancy (ROD).

SF 388

Product Quality Deficiency Report.

#### A.3. **FIELD MANUAL**

FM 11-32

Combat Net Radio Operations.

FM 21-11

Artificial Respiration.

FM 24-18

Tactical Single-Channel Radio Communication Techniques.

#### A.4. **TECHNICAL BULLETINS**

TB 11-5820-890-10-2

AN/PSC-7 Radio Set

TB 11-5820-890-10-3

Wireline Adapter Interconnect Cable, CX-13310/VRC

TB 11-5820-890-10-4

Variable Format Message Entry Device, AN/GSC-21

TB 11-5820-890-10-5

Tactical Fire Direction System, AN/GSC-10

TB 11-5820-890-10-6

Lightweight Digital Fax, AN/UXC-7

TB 11-5820-890-10-7

Secure Net Radio Interface Unit, KY-90

TB 11-5820-890-10-8

Battery Computer System, AN/GYK-29

TB 11-5820-890-10-9

Digital Message Device, AN/PSG-2

TB 11-5820-890-10-10

FIST-V Digital Message Device, AN/PSG-5

TB 11-5820-890-10-11

Maneuver Control System (MCS)

TB 11-5820-890-10-12

Lightweight TACFIRE

**TM 11-5820-890-10-8**

TB 11-5820-890-10-13	Mortar Ballistic Computer, M23 (MBC)
TB 11-5820-890-10-14	Loudspeaker, LS -671
TB 11-5820-890-10-15	Operation of AN/TPQ-36 Firefinder
TB 11-5820-890-10-16	Operation of Battery Computer System to Gun Display Unit
TB 11-5820-890-10-17	Operation of AN/PSC-3 Radio Set
TB 11-5820-890-10-18	Operation of AFATDS System AN/GYG-1 (U) 1, 2, 3, &4

**A.5. TECHNICAL MANUALS**

TM 11-5810-394-14 & P	Operator' s; Unit, Direct Support, and Specialized Repair Activity Maintenance Manual with Repair Parts and Special Tools List for Automated Net Control Device.
TM 11-5820-890-10-6	SINGARS ICOM Ground Radio Operator' s Pocket Guide
TM 11-5820-890-10-7	SINGARS ICOM Ground Radio NCS Pocket Guide
TM 11-5825-291-13	Operations and Maintenance Manual, Satellite Signal Navigation Set, AN/PSN-11
TM 750-244-2	Procedure for Destruction of Electronics Materiel to Prevent Enemy Use

**A.6. MISCELLANEOUS PUBLICATIONS**

AR 735-244-2	Reporting of Item and Packaging Discrepancies
DA Pam 25-30	Consolidated Index of Army Publications and Blank Forms.
DA Pam 738-750	The Army Maintenance Management System.
SB 11-624	Warning Notice for Vehicles in Which Radios are Mounted.

**JULIAN DATE CALENDAR (REGULAR YEAR)**

DAY/MO	JAN	FEB	MAR	APR	MAY	JUN	JUL	AUG	SEP	OCT	NOV	DEC
1	01	32	60	91	21	52	82	13	44	74	05	35
2	02	33	61	92	22	53	83	14	45	75	06	36
3	03	34	62	93	23	54	84	15	46	76	07	37
4	04	35	63	94	24	55	85	16	47	77	08	38
5	05	36	64	95	25	56	86	17	48	78	09	39
6	06	37	65	96	26	57	87	18	49	79	10	40
7	07	38	66	97	27	58	88	19	50	80	11	41
8	08	39	67	98	28	59	89	20	51	81	12	42
9	09	40	68	99	29	60	90	21	52	82	13	43
10	10	41	69	00	30	61	91	22	53	83	14	44
11	11	42	70	01	31	62	92	23	54	84	15	45
12	12	43	71	02	32	63	93	24	55	85	16	46
13	13	44	72	03	33	64	94	25	56	86	17	47
14	14	45	73	04	34	65	95	26	57	87	18	48
15	15	46	74	05	35	66	96	27	58	88	19	49
16	16	47	75	06	36	67	97	28	59	89	20	50
17	17	48	76	07	37	68	98	29	60	90	21	51
18	18	49	77	08	38	69	99	30	61	91	22	52
19	19	50	78	09	39	70	00	31	62	92	23	53
20	20	51	79	10	40	71	01	32	63	93	24	54
21	21	52	80	11	41	72	02	33	64	94	25	55
22	22	53	81	12	42	73	03	34	65	95	26	56
23	23	54	82	13	43	74	04	35	66	96	27	57
24	24	55	83	14	44	75	05	36	67	97	28	58
25	25	56	84	15	45	76	06	37	68	98	29	59
26	26	57	85	16	46	77	07	38	69	99	30	60
27	27	58	86	17	47	78	08	39	70	00	31	61
28	28	59	87	18	48	79	09	40	71	01	32	62
29	29		88	19	49	80	10	41	72	02	33	63
30	30		89	20	50	81	11	42	73	03	34	64
31	31		90		51		12	43		04		65

**JULIAN DATE CALENDAR (LEAP YEAR)**

1	01	32	61	92	22	53	83	14	45	75	06	36
2	02	33	62	93	23	54	84	15	46	76	07	37
3	03	34	63	94	24	55	85	16	47	77	08	38
4	04	35	64	95	25	56	86	17	48	78	09	39
5	05	36	65	96	26	57	87	18	49	79	10	40
6	06	37	66	97	27	58	88	19	50	80	11	41
7	07	38	67	98	28	59	89	20	51	81	12	42
8	08	39	68	99	29	60	90	21	52	82	13	43
9	09	40	69	00	30	61	91	22	53	83	14	44
10	10	41	70	01	31	62	92	23	54	84	15	45
11	11	42	71	02	32	63	93	24	55	85	16	46
12	12	43	72	03	33	64	94	25	56	86	17	47
13	13	44	73	04	34	65	95	26	57	87	18	48
14	14	45	74	05	35	66	96	27	58	88	19	49
15	15	46	75	06	36	67	97	28	59	89	20	50
16	16	47	76	07	37	68	98	29	60	90	21	51
17	17	48	77	08	38	69	99	30	61	91	22	52
18	18	49	78	09	39	70	00	31	62	92	23	53
19	19	50	79	10	40	71	01	32	63	93	24	54
20	20	51	80	11	41	72	02	33	64	94	25	55
21	21	52	81	12	42	73	03	34	65	95	26	56
22	22	53	82	13	43	74	04	35	66	96	27	57
23	23	54	83	14	44	75	05	36	67	97	28	58
24	24	55	84	15	45	76	06	37	68	98	29	59
25	25	56	85	16	46	77	07	38	69	99	30	60
26	26	57	86	17	47	78	08	39	70	00	31	61
27	27	58	87	18	48	79	09	40	71	01	32	62
28	28	59	88	19	49	80	10	41	72	02	33	63
29	29	60	89	20	50	81	11	42	73	03	34	64
30	30		90	21	51	82	12	43	74	04	35	65
31	31		91		52		13	44		05		66

TIME ZONE MAP

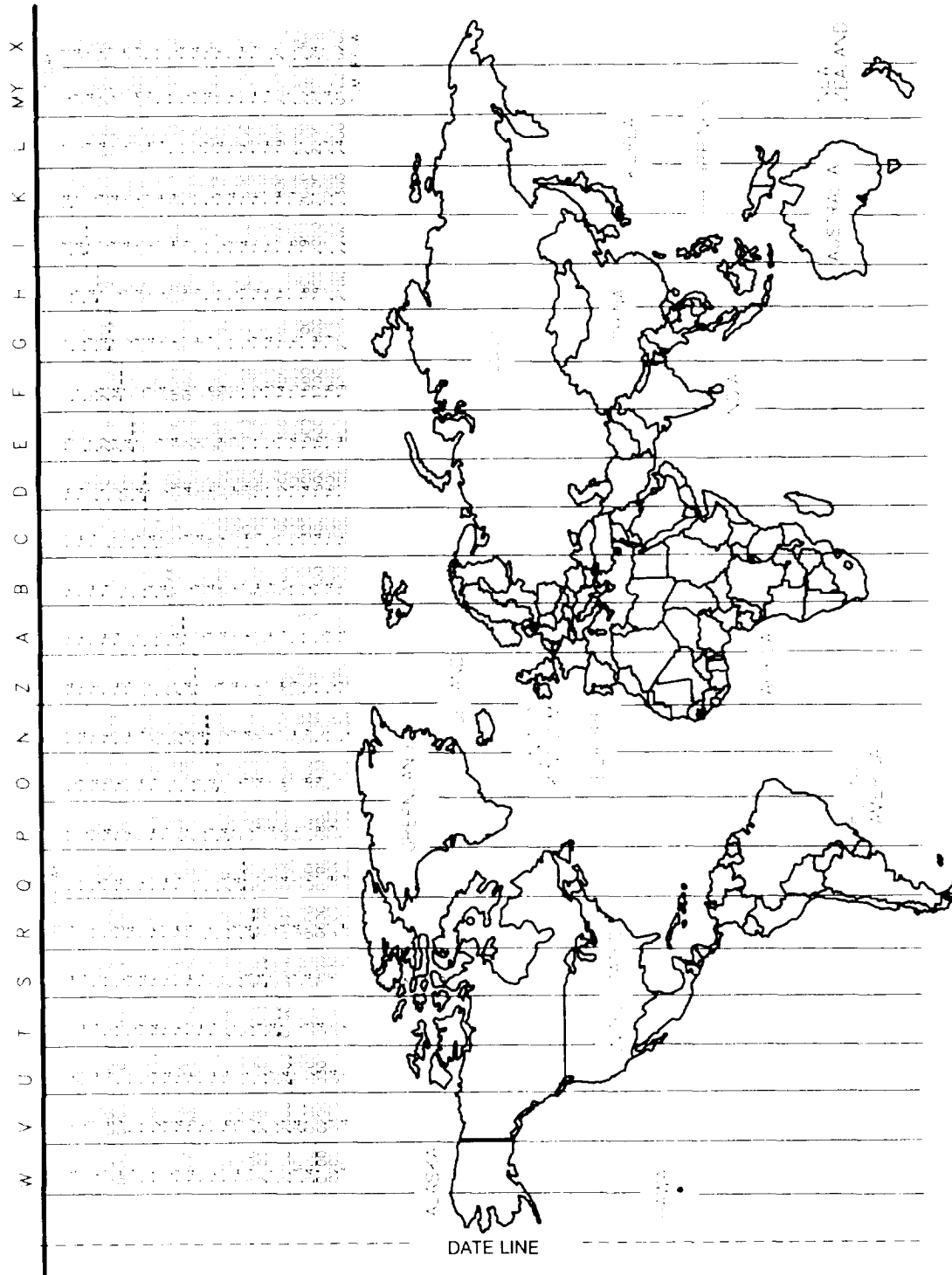

## APPENDIX B

### COMPONENTS OF END ITEM AND BASIC ISSUE ITEMS LISTS

---

#### SECTION I

#### INTRODUCTION

##### B.1. **SCOPE**

This appendix lists components of end item for Radio Sets AN/PRC-119A/D/F and AN/VRC-87A/D/F thru AN/VRC-92A/D/F, and AN/VRC-87C to help you inventory items required for safe and efficient operation.

##### B.2. **GENERAL**

The Components of End Item List is found at Section II.

This listing is for informational purposes only and is not authority to requisition replacements. These items are part of the end item, but are removed and separately packaged for transportation or shipment. As part of the end item, these items must be with the end item whenever it is issued or transferred between property accounts. The list is divided into sublistings for each radio set. Illustrations are furnished to assist you in identifying the items.

##### B.3. **EXPLANATION OF COLUMNS**

The following explains the columns found in the tabular listings.

- a. **Column (1), Illustration Number (Illus No.).** This column indicates the number of the illustration showing the item.
- b. **Column (2), National Stock Number.** This column indicates the national stock number assigned to the item and will be used for requisitioning purposes.
- c. **Column (3), Description.** This column indicates the federal item name and if required, a minimum description to identify and locate the item. The last line for each item indicates the CAGEC (in parentheses), followed by the part number.
- d. **Column (4), Unit of Measure (U/M).** This column indicates the measure used in performing the actual operational maintenance function. This measure is expressed by a two-character alphabetical abbreviation (e.g., ea, in, pr).
- e. **Column (5), Quantity Required (Qty Reqd).** This column indicates the quantity of the item authorized to be used with/on the equipment.

SECTION II. COMPONENTS OF END ITEM

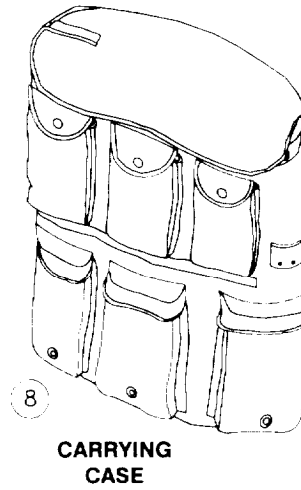
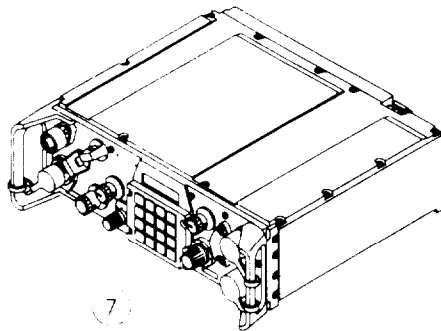
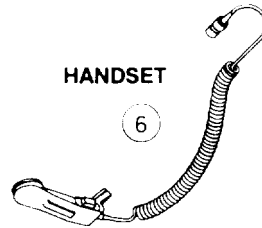
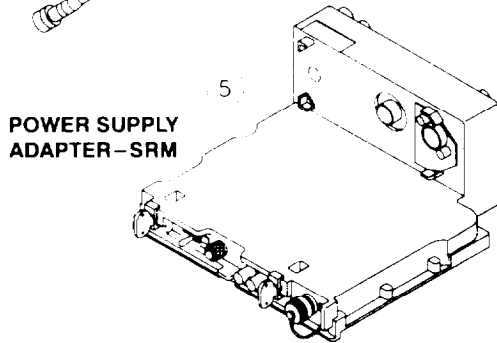
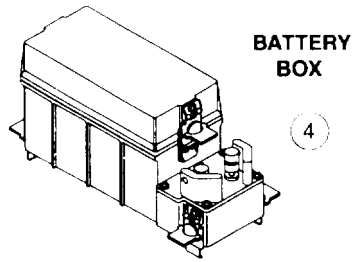
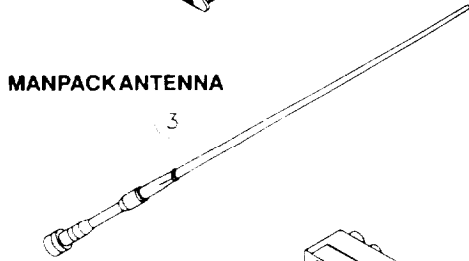
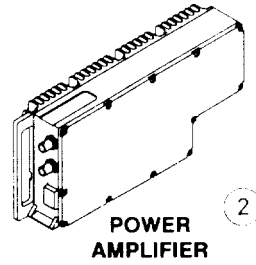
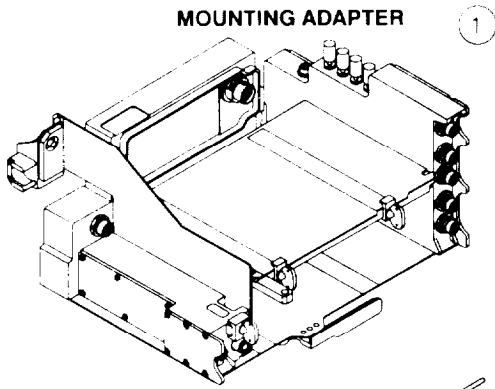

## SECTION II. COMPONENTS OF END ITEM

Continued

**CONTROL CABLE**  
CX-13291

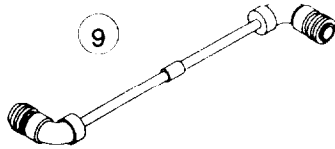

**RF CABLE**  
CG-3856

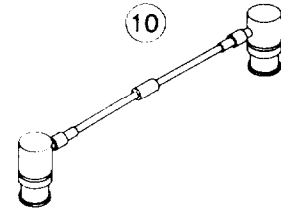

**W2 CABLE**

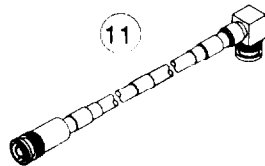

**W4 CABLE**

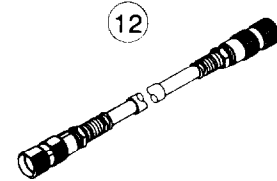

**POWER CABLE**  
(BETWEEN MOUNTS)  
CX-13303

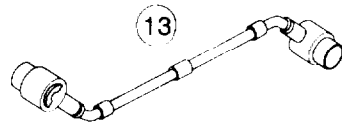

**MOUNTING BASE**  
MT-6353

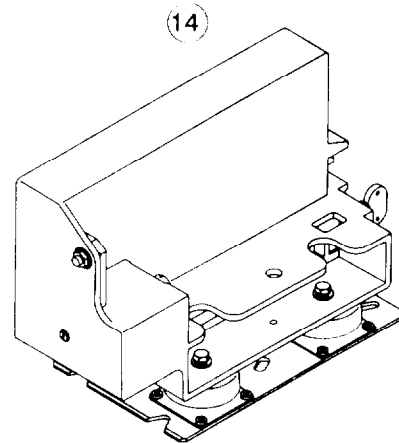

**SPECIAL PURPOSE**  
**CABLE**  
CX-13314

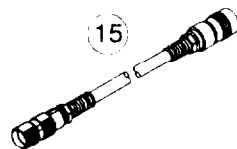

**LEVER, LOCKING**

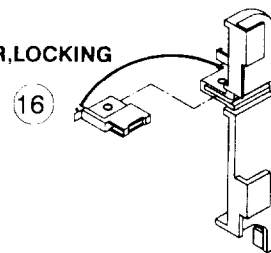

## SECTION II. COMPONENTS OF END ITEM

Continued

W4 CABLE

17

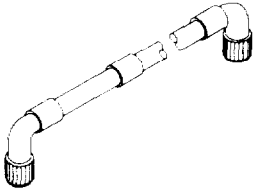

HANDHELD REMOTE CONTROL  
RADIO DEVICE  
C-12493/U

18

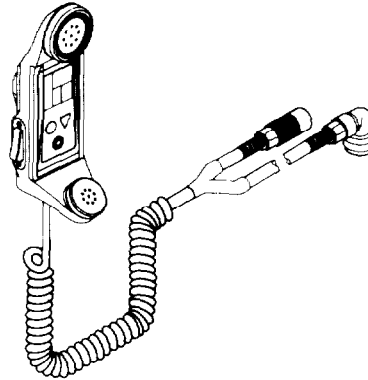

BATTERY BOX  
CY-8523C/PRC

19

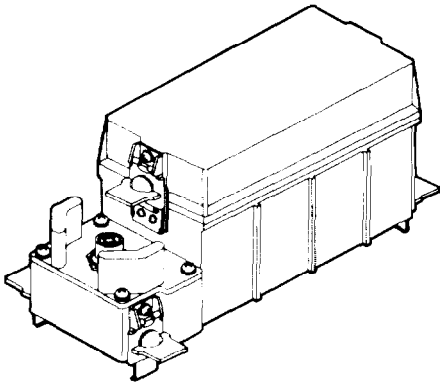

RECEIVER-TRANSMITTER, RADIO  
RT-1523E(C)/U

20

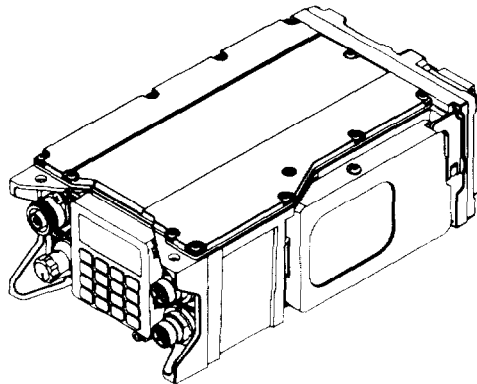

LEVER, LOCKING (ASIP)

21

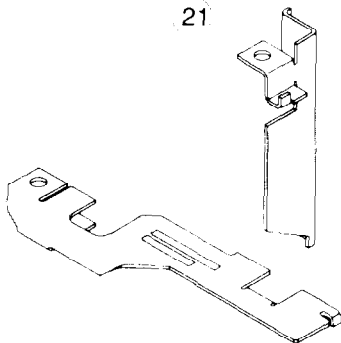



SECTION II. COMPONENTS OF END ITEM Continued

(1) Illus No.	(2) National Stock Number	(3) Description (CAGEC) and Part Number	(4) U/M	(5) Qty Reqd
3	5820-01-267-9482 5820-01-421-0801 5820-01-451-8252	<b>RADIO SET AN/PRC-119A (MANPACK)</b> <b>RADIO SET AN/PRC-119D (MANPACK) ****</b> <b>RADIO SET AN/PRC-119F (MANPACK) *****</b> ****(Denotes SIP)***** (Denotes ASIP)		
4	5985-01-235-9189	<b>Antenna Manpack:</b> AS-3683/PRC (80063) A3132025-1	ea	1
19	6160-01-284-4200 6160-01-304-2034	<b>Battery Box:</b> CY-8523A/PRC (80063) A3018381-1* CY-8523B/PRC (80063) A3132600-1* *(Required for MP SIP RT as an RCU)	ea	1
6	6160-01-424-8514	<b>CY-8523C/PRC (80063) A3249648-1**</b> **(Required for MP radio using HRCRD)	ea	1
18	5965-00-043-3463	<b>Handset/HRCRD;</b> H-250/U (80058) (or) Handheld Remote Control Radio Device:***	ea	1
8	5895-01-432-8370	C-12493/U (80063) A3249865-1 **(Requires use of Battery Box, CY-8523C/PRC)	ea	1
7	5820-01-322-3477 5895-01-461-4505	<b>Carrying Case, Radio</b> (80063) A3142076-1 (80063) A3142076-2	ea	1
20	5820-01-234-8093 5820-01-318-7990 5820-01-365-2725 5820-01-363-6929 5820-01-410-8981 5820-01-444-1219	<b>Receiver-Transmitter, Radio:</b> RT-1523(C)/U (80063) A3018860-1 RT-1523A(C)/U (80063) A3131300 RT-1523B(C)/U (80063) A3018860-5 RT-1523C(C)/U (80063) A3249545-1 ****(or) RT-1523D(C)/U (80063) A3137700**** RT-1523E(C)/U (80063) A3267334 *****	ea	1
1	5820-01-267-9480 5820-01-351-5259 5820-01-451-8248	<b>RADIO SET AN/VRC-87A (SHORT RANGE)</b> <b>RADIO SET AN/VRC-87D (SHORT RANGE)****</b> <b>RADIO SET AN/VRC-87F (SHORT RANGE)****</b>		
12	5895-01-188-8819 5895-01-304-8389 5895-01-334-3164 5895-01-421-0093 5895-01-422-8781 5895-01-444-1218	<b>Amplifier-Adapter, Vehicular (VAA)</b> AM-7239/VRC (80063) A3013365-1 AM-7239A/VRC (80063) A3132035-1 AM-7239B/VRC (80063) A3148136-1 AM-7239C/VRC (80063) A3245066-1****(or) AM-7239D/VRC (80063) A3163600**** AM-7239E/VRC (80063) A3267335*****	ea	1
17	5995-01-310-0335	<b>Cable Assembly, Special Purpose (W4)</b> (80063) A3103735--7 (or)	ea	1
7	5995-01-426-6728	(80063) A3255571 (RT to VAA) ****	ea	1
7	5820-01-234-8093 5820-01-318-7990	<b>Receiver-Transmitter, Radio:</b> RT-1523(C)/U (80063) A3018860-1 RT-1523A(C)/U (80063) A3131300	ea	1

# Denotes Dismount Components

SECTION II. COMPONENTS OF END ITEM Continued

(1) Illus No.	(2) National Stock Number	(3) Description (CAGEC) and Part Number	(4) U/M	(5) Qty Reqd
	5820-01-267-9480	RADIO SET AN/VRC-87A		
	5820-01-351-5259	RADIO SET AN/VRC-87D (continued)****		
	5820-01-351-5259	RADIO SET AN/VRC-87F (continued)*****		
	5820-01-365-2725	RT-1523B(C)/U (80063) A3018860-5		
	5820-01-363-6929	RT-1523C(C)/U (80063) A3249545-1 ****(or)		
	5820-01-410-8981	RT-1523D(C)/U (80063) A3137700****		
	5820-01-444-1219	RT-1523E(C)/U (80063) A3267334*****		
16	5340-01-430-4723	<b>Lever, Locking (80063)</b>	ea	1
2	5340-01-456-7985	Lever, Locking (ASIP) (80063) A3256669-1*****		
	5820-01-267-9481	RADIO SET AN/VRC-88A (SHORT RANGE / DISMOUNT)		
	5820-01-352-1694	RADIO SET AN/VRC-88D****		
	5820-01-452-8735	RADIO SET AN/VRC-88F****		
1		<b>Amplifier-Adapter, Vehicular (VAA)</b>	ea	1
	5895-01-188-8819	AM-7239/VRC (80063) A3013365-1		
	5895-01-304-8389	AM-7239A/VRC (80063) A3132035-1		
	5895-01-334-3164	AM-7239B/VRC (80063) A3148136-1		
	5895-01-421-0093	AM-7239C/VRC (80063) A3245066-1****(or)		
	5895-01-422-8781	AM-7239D/VRC (80063) A3163600****		
	5895-01-444-1218	AM-7239E/VRC (80063) A3267335*****		
12	5995-01-310-0335	<b>Cable Assembly, Special Purpose (W4)</b>	ea	1
		(80063) A3103735-7 (or)		
17	5995-01-426-6728	(80063) A3255571 (RT to VAA) ****	ea	1
3	#	<b>Antenna Manpack:</b>		
	5985-01-235-9189	AS-3683/PRC (80063) A3132025-1	ea	1
4	#	<b>Battery Box:</b>	ea	1
	6160-01 -284-4200	CY-8523A/PRC (80063) A3018381-1* (or)		
	6160-01 -304-2034	CY-8523B/PRC (80063) A3132600-1* (or)		
	6160-01 -424-8514	CY-8523C/PRC (80063) A3249648-1**		
6	#	<b>Handset/HRCRD;</b>		
	5965-00-043-3463	H-250/U (80058) (or)	ea	1
		Handheld Remote Control Radio Device.***		
18	5895-01-432-8370	C-12493/U (80063) A3249865-1	ea	1
8	#	<b>Carrying Case, Radio</b>	ea	1
	5820-01-322-3477	(80063) A3142076-1		
	5895-01-461-4505	(80063) A3142076-2		
7		<b>Receiver-Transmitter, Radio:</b>	ea	1
	5820-01-234-8093	RT-1523(C)/U (80063) A3018860-1		
	5820-01-318-7990	RT-1523A(C)/U (80063) A3131300		
	5820-01-365-2725	RT-1523B(C)/U (80063) A3018860-5		
	5820-01-363-6929	RT-1523C(C)/U (80063) A3249545-1 ****(or)		
	5820-01-410-8981	RT-1523D(C)/U (80063) A3137700****		
20	5820-01-444-1219	RT-1523E(C)/U (80063) A3267334*****		
16	5340-01-430-4723	<b>Lever, Locking (80063)</b>	ea	1
21	5340-01-456-7985	Lever, Locking (ASIP) (80063) A3256669-1*****		

# Denotes Dismount Components

SECTION II. COMPONENTS OF END ITEM Continued

(1) Illus No.	(2) National Stock Number	(3) Description (CAGEC) and Part Number	(4) U/M	(5) Qty Reqd
1	<b>5820-01-267-9479</b> <b>5820-01-420-6619</b> <b>5820-01-451-8247</b>  5895-01-188-8819 5895-01-304-8389 5895-01-334-3164 5895-01-421-0093 5895-01-422-8781 5895-01-444-1218	<b>RADIO SET AN/VRC-89A (LONG/SHORT RANGE)</b> <b>RADIO SET AN/VRC-89D****</b> <b>RADIO SET AN/VRC-89F*****</b>  <b>Amplifier-Adapter, Vehicular (VAA)</b> AM - 7239/VRC (80063) A3013365-1 AM - 7239A/VRC (80063) A3132035-1 AM - 7239B/VRC (80063) A3148136-1 AM - 7239C/VRC (80063) A3245066-1**** (or) AM - 7239D/VRC (80063) A3163600**** AM - 7239E/VRC (80063) A3267335*****	ea	1
2	5895-01-195-4844 5895-01-306-8093 5895-01-407-2627	<b>Amplifier, Radio-Frequency: (PA)</b> AM - 7238/VRC (80063) A3013357-1 AM - 7238A/VRC (80063) A3132135-1 AM - 7238B/VRC (80063) A3210919-1	ea	1
11	5995-01-304-2026	<b>Cable Assembly, Radio- Frequency (W2)</b> (80063) A3013824-21-3 (RT to PA)	ea	1
12	5995-01-310-0355	<b>Cable Assembly, Special Purpose (W4)</b> (80063) A3103735 - 7 (or)	ea	2
17	5995-01-426-6728	(80063) A3255571 (RT to VAA) ****	ea	2
7	5820-01-234-8093 5820-01-318-7990 5820-01-365-2725 5820-01-363-6929 5820-01-410-8981	<b>Receiver-Transmitter, Radio:</b> RT - 1523(C)/U (80063) A3018860-1 RT - 1523A(C)/U (80063) A3131300 RT - 1523B(C)/U (80063) A3018860-5 RT - 1523C(C)/U (80063) A3249545-1 **** (or) RT - 1523D(C)/U (80063) A3137700 ****	ea	2
20	5820-01-444-1219	RT - 1523E(C)/U (80063) A3267334 *****		
16	5340-01-392-0048	<b>Lever, Locking (80063)</b>	ea	1
21	5340-01-456-7985	Lever, Locking (ASIP) (80063) A3256669-1*****		
1	<b>5820-01-267-9481</b> <b>5820-01-420-6618</b> <b>5820-01-451-8246</b>	<b>RADIO SET AN/VRC-90A (LONG RANGE)</b> <b>RADIO SET AN/VRC-90D (LONG RANGE)****</b> <b>RADIO SET AN/VRC-90F (LONG RANGE)*****</b>	ea	1
1	5895-01-188-8819 5895-01-304-8389 5895-01-334-3164 5895-01-421-0093 5895-01-422-8781 5895-01-444-1218	<b>Amplifier-Adapter, Vehicular (VAA)</b> AM - 7239/VRC (80063) A3013365-1 AM - 7239A/VRC (80063) A3132035-1 AM - 7239B/VRC (80063) A3148136-1 AM - 7239C/VRC (80063) A3245066-1**** (or) AM - 7239D/VRC (80063) A3163600**** AM - 7239E/VRC (80063) A3267335*****	ea	1
2	5895-01-195-4844 5895-01-306-8093 5895-01-407-2627	<b>Amplifier, Radio-Frequency: (PA)</b> AM - 7238/VRC (80063) A3013357-1 AM - 7238A/VRC (80063) A3132135-1 AM - 7238B/VRC (80063) A3210919-1	ea	1

# Denotes Dismount Components

SECTION II. COMPONENTS OF END ITEM Continued

(1) Illus No.	(2) National Stock Number	(3) Description (CAGEC) and Part Number	(4) U/M	(5) Qty Reqd
11	5820-01-267-9481	RADIO SET AN/VRC-90A (LONG RANGE)	ea	1
	5820-01-420-6618	RADIO SET AN/VRC-90D (LONG RANGE)****		
	5820-01-451-8246	RADIO SET AN/VRC-90F (LONG RANGE)*****		
12	5995-01-304-2026	Cable Assembly, Radio-Frequency (W2) (80063) A3013824-21-3 (RT to PA)	ea	2
	5995-01-310-0355	Cable Assembly, Special Purpose (W4) (80063) A3103735-7 (or)		
17	5995-01-426-6728	(80063) A3255571 (RT to VAA) ****	ea	2
	7	Receiver-Transmitter, Radio:		
20	5820-01-234-8093	RT-1523(C)/U (80063) A3018860-1	ea	2
	5820-01-318-7990	RT-1523A(C)/U (80063) A3131300		
	5820-01-365-2725	RT-1523B(C)/U (80063) A3018860-5		
	5820-01-363-6929	RT-1523C(C)/U (80063) A3249545-1 **** (or)		
	5820-01-410-8981	RT-1523D(C)/U (80063) A3137700****		
	5820-01-444-1219	RT-1523E(C)/U (80063) A3267334*****		
1	5820-01-267-9478	RADIO SET AN/VRC-91A (LONG/SHORT-	ea	1
	5820-01-420-6621	RADIO SET AN/VRC-91D**** RANGE/DISMOUNT)		
	5820-01-451-8249	RADIO SET AN/VRC-91F*****		
	5895-01-188-8819	Amplifier-Adapter, Vehicular (VAA)		
	5895-01-304-8389	AM-7239/VRC (80063) A3013365-1		
	5895-01-334-3164	AM-7239A/VRC (80063) A3132035-1		
	5895-01-421-0093	AM-7239B/VRC (80063) A3148136-1		
5895-01-422-8781	AM-7239C/VRC (80063) A3245066-1**** (or)			
2	5895-01-444-1218	AM-7239D/VRC (80063) A3163600****	ea	1
	5895-01-195-4844	AM-7239E/VRC (80063) A3267335*****		
	5895-01-306-8093	Amplifier, Radio-Frequency: (PA)		
11	5895-01-407-2627	AM-7238/VRC (80063) A3013357-1	ea	1
	5995-01-304-2026	AM-7238A/VRC (80063) A3132135-1		
	5995-01-304-2026	AM-7238B/VRC (80063) A3210919-1		
12	5995-01-304-2026	Cable Assembly, Radio- Frequency (W2) (80063) A3013824-21-3 (RT to PA)	ea	1
	5995-01-310-0355	Cable Assembly, Special Purpose (W4) (80063) A3103735-7 (or)		
17	5995-01-426-6728	(80063) A3255571 (RT to VAA) ****	ea	2
	3	Antenna Manpack:		
4	5985-01-235-9189	AS-3683/PRC (80063) A3132025-1	ea	1
	6160-01-284-4200	Battery Box:		
	6160-01-304-2034	CY-8523A/PRC (80063) A3018381-1*		
	6160-01-424-8514	CY-8523B/PRC (80063) A3132600-1*		
		CY-8523C/PRC (80063) A3249648-1**		

# Denotes Dismount Components

SECTION II. COMPONENTS OF END ITEM Continued

(1) Illus No.	(2) National Stock Number	(3) Description (CAGEC) and Part Number	(4) U/M	(5) Qty Reqd
	5820-01-267-9478 5820-01-420-6621 5820-01-451-8249	<b>RADIO SET AN/VRC-91A (LONG/SHORT- RADIO SET AN/VRC-91D**** RANGE/DISMOUNT) RADIO SET AN/VRC-91F**** (continued)</b>		
6	# 5965-00-043-3463	<b>Handset/HRCRD; H-250/U (80058) (or) Handheld Remote Control Radio Device:***</b>	ea	1
18	5895-01-432-8370	C-12493/U (80063) A3249865-1	ea	1
8	#	<b>Carrying Case, Radio</b>	ea	1
	5820-01-322-3477 5895-01-461-4505	(80063) A3142076-1 (80063) A3142076-2		
7		<b>Receiver-Transmitter, Radio:</b>	ea	2
	5820-01-234-8093 5820-01-318-7990 5820-01-365-2725 5820-01-363-6929 5820-01-410-8981	RT-1523(C)/U (80063) A3018860-1 RT-1523A(C)/U (80063) A3131300 RT-1523B(C)/U (80063) A3018860-5 RT-1523C(C)/U (80063) A3249545-1 ****(or) RT-1523D(C)/U (80063) A3137700****		
20	5820-01-444-1219	RT-1523E(C)/U (80063) A3267334****		
16	5340-01-430-4723	<b>Lever, Locking (80063)</b>	ea	1
21	5340-01-456-7985	Lever, Locking (ASIP) (80063) A3256669-1****		
	5820-01-267-9477 5820-01-421-2605 5820-01-451-8250	<b>RADIO SET AN/VRC-92A (LONG RANGE/LONG RANGE) RADIO SET AN/VRC-92D**** RADIO SET AN/VRC-92F****</b>		
1		<b>Amplifier-Adapter, Vehicular (VAA)</b>	ea	1
	5895-01-188-8819 5895-01-304-8389 5895-01-334-3164 5895-01-421-0093 5895-01-422-8781 5895-01-444-1218	AM-7239/VRC (80063) A3013365-1 AM-7239A/VRC (80063) A3132035-1 AM-7239B/VRC (80063) A3148136-1 AM-7239C/VRC (80063) A3245066-1****(or) AM-7239D/VRC (80063) A3163600**** AM-7239E/VRC (80063) A3267335****		
2		<b>Amplifier, Radio-Frequency: (PA)</b>	ea	2
	5895-01-195-4844 5895-01-306-8093 5895-01-407-2627	AM-7238/VRC (80063) A3013357-1 AM-7238A/VRC (80063) A3132135-1 AM-7238B/VRC (80063) A3210919-1		
14	5975-01-235-1962	<b>Mounting Base, Electrical Equipment</b> MT-6353/VRC (80063) A3014053-1	ea	1
9	5995-01-222-4209	<b>Cable Assembly, Special Purpose</b> CX-13291/VRC (80063) A3104037	ea	1
10	5995-01-219-7025	<b>Cable Assembly, Radio</b> CG-3856/VRC (80063) A3014032-3	ea	1
11	5995-01-304-2026	<b>Cable Assembly, Radio-Frequency (W2)</b> (80063) A3013824-21-3 (RT to PA)	ea	1
		<b>Cable Assembly, Special Purpose (W4)</b>	ea	2
12	5995-01-310-0335	(80063) A3103735-7 (or)		
17	5995-01-426-6728	(80063) A3255571 (RT to VAA) ****		

# Denotes Dismount Components

SECTION II. COMPONENTS OF END ITEM Continued

(1) Illus No.	(2) National Stock Number	(3) Description (CAGEC) and Part Number	(4) U/M	(5) Qty Reqd
13	5820-01-267-9477 5820-01-421-2605 5820-01-451-8249 5995-01-300-9324	RADIO SET AN/VRC-92A (LONG RANGE/LONG RANGE) RADIO SET AN/VRC-92D**** RADIO SET AN/VRC-92F***** (continued) <b>Cable Assembly, Power</b> CX-13303/VRC (80063) A3014040-9 (VAA to PA)	ea	1
7	5820-01-234-8093 5820-01-318-7990 5820-01-365-2725 5820-01-363-6929 5820-01-410-8981	<b>Receiver-Transmitter, Radio:</b> RT-1523(C)/U (80063) A3018860-1 RT-1523A(C)/U (80063) A3131300 RT-1523B(C)/U (80063) A3018860-5 RT-1523C(C)/U (80063) A3249545-1 **** (or) RT-1523D(C)/U (80063) A3137700****	ea	2
20 16 21	5820-01-444-1219 5340-01-392-0048 5340-01-456-7985	RT-1523E(C)/U (80063) A3267334***** <b>Lever, Locking (80063)</b> Lever, Locking (ASIP) (80063) A3256669-1*****	ea	1
5	5820-01-304-2045 6130-01-284-4195	<b>RADIO SET AN/VRC-87C (SINGLE RADIO MOUNT)</b> <b>Adapter, Power Supply (PSA)</b> MX-10862/VRC (80063) A3018352-1	ea	1
15	5995-01-323-2729	<b>Cable Assembly, Special Purpose</b> CX-13314/VRC (80063) A3142069-1	ea	1
7	5820-01-234-8093 5820-01-318-7990 5820-01-365-2725	<b>Receiver-Transmitter, Radio:</b> RT-1523(C)/U (80063) A3018860-1 RT-1523A(C)/U (80063) A3131300 RT-1523B(C)/U (80063) A3018860-5	ea	1

# Denotes Dismount Components

### **SECTION III. BASIC ISSUE ITEMS**

There are no BII items associated with SINCGARS Radio Configurations.

THIS PAGE INTENTIONALLY  
BLANK.



## APPENDIX C

### ADDITIONAL AUTHORIZATION LIST

#### SECTION I. INTRODUCTION

**C.1. SCOPE**

This appendix lists additional items you are authorized for the support of Radio Sets AN/PRC-119A/D/F and AN/VRC-87A/D/F through AN/VRC-92A/D/F and AN/VRC-87C.

**C.2. GENERAL**

This list identifies items that do not have to accompany the radio set and that do not have to be turned in with it. These items are all authorized to you by CTA, MTOE, TDA, or JTA.

**C-3. EXPLANATION OF COLUMNS**

National stock numbers, descriptions, and quantities are provided to help you identify and request the additional items you require to support this equipment. The items are listed in name and grouped into equipment types.

### SECTION II. ADDITIONAL AUTHORIZATION LIST

(1) National Stock Number	(2) Description (CAGEC) and Part Number	(3) U/M	(4) Qty Auth
	<b>Antenna, Manpack:</b>		
5985-01-340-1043	AS-4266/PRC (80063) A3167657-1 (extended range) or	ea	1
5985-01-425-7305	AS-4266A/PRC (80063) A3256531-1	ea	1
	<b>Bar, Latch (Locking Lever):</b>		
5340-01-430-4723	Bar, Latch (80063) A3256492	ea	1
5340-01-456-7985	<b>Bar, Latch (ASIP) (80063) A3256669-1</b>	ea	1
	<b>Batteries:</b>		
6135-01-214-6441	Battery, Non-rechargeable, BA-5372/U (Lithium hold up) <b>(80058)</b>	ea	1
6135-01-036-3495	Battery, Non-rechargeable, BA-5590/U (Lithium manpack primary power)		1
5135-01-063-3918	Battery, Rechargeable, BA-590/U (80058)	ea	1
5140-01-419-8187	Battery, Rechargeable, BA-390/U Manpack primary power <b>(80058)</b>	ea	1
6135-01-462-4442	Case, <b>Battery</b> Assembly (80063) A3272554-1	ea	1
3130-01-427-9604	Charger, Manpack Battery PP-8444	ea	*
5940-01-427-9710	Adapter, AP-390	ea	*
5940-01-427-9395	Adapter Cable, 24 VDC	ea	*
5935--01-462-6624	Adapter Connector (2Wire) (80063) A3272557-1	ea	*
	<b>Control, Receiver-Transmitter:</b>		
5895-01-277-2680	C-11561 (C)/U (80058) (Initially issued with the following components: LS-685/U 1 ea, Battery Box CY-8523A/PRC or CY-8523B/PRC 1 ea, and Handset H-250/U 1 ea. This issue is at time of SINCGARS fielding only).		

\*As Required

**SECTION II. ADDITIONAL AUTHORIZATION LIST** Continued

(1) National Stock Number	(2) Description (CAGEC) and Part Number	(3) U/M	(4) Qty Auth
5340-01-461-4741	Strap Assembly Hand (80063) A3274735-1	ea	*
	<b>Data Transfer Device:</b>		
5810-01-343-1194	AN/CYZ-10 (ANCD) (98230)	ea	*
	<b>Loudspeaker:</b>		
5965-01-222-1420	LS-671/VRC (80058) (Radio System)	ea	1
5965-01-295-1125	LS-685/U (80058) (RCU ONLY)	ea	1
	<b>Cable Assembly, Special Purpose:</b>	ea	1
5995-01-358-1078	CX-13292/VRC (80058) (50ft) (VAA to LS-671)	ea	1
5995-01-382-6869	CX-13292/VRC (80058) (100ft) (VAA to LS-671)	ea	1
5995-01-244-0016	CX-13298/VRC (80058) A3014033-1 (5 in)	ea	1
5995-01-286-2701	CX-13298/VRC (80058) A3014033-2 (15 ft)	ea	1
5995-01-303-0308	CX-13308/VRC (80058) (AN-PSG-2, 2A, 5 Adapter Cable)	ea	1
5995-01-312-7932	CX-13310/VRC (80058) (HYX-57 Adapter Cable)	ea	1
5995-01-379-9743	CX-13311/VRC (80058) (MST-20 Adapter Cable)	ea	1
5995-01-365-2519	CX-13312/VRC (80058) (AN/PSC-3 Adapter Cable)	ea	1
5995-01-323-9033	CX-13402/VRC (80058) (TACFIRE Magic Cable)	ea	1
5995-01-335-7878	CX-13404/VRC (80058) (KY-90 Adapter Cable)	ea	1
5995-01-348-2264	CX-13417/VRC (80058) (Splitter Cable)	ea	1
5995-01-387-4422	CX-13465/VRC (80058) (Digital Adapter Cable)	ea	1
5995-01-379-9689	CX-13467/VRC (80058) (ANCD Fill Cable 18 in)	ea	1
TBD	CX-13490/VRC A3210567 8 ft (FA Extender Cable)	ea	1
TBD	Cable, Special Purpose (SIP/ASIP RT to PC)	ea	1
	<b>Adapter:</b>		
5810-01-026-962;	HYX-57/TSEC (98230) ON241760	ea	1
5935-01-462-6624	Adapter, 2-wire (ASIP RCU)	ea	*
	<b>INSTALLATION KIT, ELECTRONIC EQUIPMENT</b>	ea	1
	MK- (mounts AN/VRC-87A/D/F through AN/VRC-92A/D/F Radio Sets and Ancillary equipment in vehicles) (80063)		
	<b>REFER TO DA PAM 25-30 FOR LISTINGS OF INDIVIDUAL KITS.</b>		

## APPENDIX E

### REFERENCE DATA

#### (Nomenclature Cross-Reference List, Abbreviations, and Glossary)

<b>NOMENCLATURE CROSS-REFERENCE LIST</b>
--

<u>COMMON NAME</u>	<u>OFFICIAL NOMENCLATURE</u>
Battery (HUB)	Battery, Non-rechargeable, BA-5372/U
Battery (main power)	Battery, BA-5590/U (Lithium)
Battery box	Battery Box, CY-8523/A/B/PRC
Battery tray	Tray, Battery, CY-8664/VRC
Cable set (FHMUX)	Cable Assembly Set, Electrical Equipment, CX-13436/VRC
Control-monitor	Control-Monitor, C-11291/A/VRC
Dismount radio	AN/VRC-88A/-91A
FHMUX	Multiplexer, Frequency Hopping, TD-1456/VRC
Field pack	Carrying Case, Radio
Fill device	Automated Net Control Device, AN/CYZ-10
Handset	Handset, H-250/U
HRCRD	Handheld Remote Control Radio Device, C-12493/U
Loudspeaker	Loudspeaker, LS-671/VRC, or LS-685/U
Manpack antenna	Antenna, Manpack, AS-3683/PRC or AS-4266/PRC
Manpack radio	AN/PRC-119A
Mounting base	Mounting Base, MT-6352/A/VRC
Power amplifier	Amplifier, Radio Frequency, AM-7238/A/B/VRC
Power amplifier mount	Mounting Base, MT-6353/VRC
Radio	Receiver-Transmitter, RT-1523/A/B/C/D/E(C)/U
Remote control unit	Control, Receiver-Transmitter (RCU), C-11561 (C)/U
Single radio mount	Mounting Base, MT-6576/VRC
Vehicular amplifier adapter	Amplifier-Adapter, Vehicular, AM-7239/A/B/C/D/E/VRC
Vehicular antenna	Antenna, Vehicular, AS-3900/VRC or AS-3916/VRC
Vehicular radio	AN/VRC-874AD/F, 87C, 88A/D/F, 89A/D/F, 90A/D/F, 91A/D/F, 92A/D/F
VIC system	intercommunications Set, AN/VIC-1 (V)
Wire line adapter	Adapter, Wire Line, HYX-57/TSEC

**ABBREVIATIONS**

<b>Abbreviation</b>	<b>Description</b>	<b>Abbreviation</b>	<b>Description</b>
AAL	additional authorization list	CM	control monitor/centimeter
ACK	acknowledge	CMSC	communications security
AD	analog data	COEI	component of end item
AK	automatic keying	COMM-EX	communications exercise
ANCD	automated net control device	COMSEC	communications security
ANT	antenna	C/S	sign, countersign
APPL	application	CT	cipher text
ATTN	attention	CVC	combat vehicle crew
AUD	audio	DA	Department of the Army
BATT	battery	DF	direction finding
BII	basic issue item	DN	down
BIT	built in test	DTD	data transfer device
BPS	bits per second	ECCM	electronic counter-counter measures
BRK	breaker	EDM	enhanced data mode
BRT	bright	EIR	equipment improvement recommendation
CAGEC	commercial and government entity code	ENTR	enter
CCI	controlled cryptographic item	EPLRS	enhanced position location reporting system
CDR	commander	ER	error
CFD	common fill device	ERF	electronic remote fill
CH	channel	ESET	FH data for one channel
CHAN	channel	EXT	external
CHG	change	FCTN	function
CID	combat identification	FH	frequency hopping
CIK	cryptographic ignition key	FH-M	frequency hopping- master
CKT	circuit	FHMUX	frequency hopping multiplexer
CLR	clear	FIST-V	fire support vehicle
CLSGN	call sign		

Abbreviation	Description	Abbreviation	Description
FM	frequency modulation	LB	pound
FOM	figure of merit	LCD	liquid crystal display
FQMER	frequency management error	LD	load
FR	response failure	LDE	local control data
FREQ	frequency	LNE	late net entry
GD	good	LO	low
GOTST	go to test	LOS	line of sight
GPS	global positioning system	LOUT	lockout
GRP	group	LR	long range
HH	hours	LR/LR	long range/long range
HI	high	LTR	letter
HR	hand receipt	M	medium
HRCRD	handheld remote control radio device	MAN	manual
HS	handset	MB	mounting base
HUB	hold --up battery	MHZ	megahertz
HZ	hertz	MK	manual keying
ICM	intercomm	MM	minutes
ICOM	integrated COMSEC	MP	manpack
ID	identification	MSE	mobile subscriber equipment
IF	intermediate frequency	MSRT	mobile subscriber radio telephone
INC	internet controller	MT	mount
INIT	initiate	MX	fill device
INT	intercomm	N	new or enhanced data mode
IP	internet protocol	NAV	navigation
JD	Julian Date	NCS	net control station
KEK	key encryption key	NOGPS	GPS device not attached
KG	kilogram	NOKEY	required key missing
KHZ	kilohertz	NRI	net radio interface
		NUM	number

Abbreviation	Description	Abbreviation	Description
OFST	offset	RWI	radio wire integration
OPR	operator	RXMT	retransmission
OTAR	over-the-air-rekey	SA	situational awareness
PA	power amplifier	SC	single channel
PAM	pamphlet	SDM	SINGARS data mode
PC	personal computer	SETDR	set data rate
PCKT	packet	SIG	signal
PLGR	precision lightweight GPS receiver	SIGO	signal officer
PM	“permanent” memory	SINGARS	single channel ground and airborne radio system
PMCS	preventive maintenance checks and services	SIP	system improvement program
POS	position	SNAP	steerable null antenna processor
PSA	power supply adapter	SLPA	SINGARS low profile antenna
PT	plain text	SOI	signal operating instructions
PTRX	plain text message being received	SOP	standing operating procedure
PTT	push-to-talk	SQ	squelch
PWR	power	SPKR	speaker
PYRO	pyrotechnic	SR	short range
QREF	quick reference	SR-D	short range radio with dismount kit
RCU	remote control unit	SR/LR	short range/long range
RCV	receive	SR/LR-D	short range/long range radio with dismount kit
REM	remote	SRM	single radio mount
RF	radio frequency		
ROD	report of discrepancy		
RT	receiver-transmitter		
RCU(RT)	SIP RT used as remote control unit (RCU)		
RV	receive variable		

<b>Abbreviation</b>	<b>Description</b>	<b>Abbreviation</b>	<b>Description</b>
STBY	stand by	TSK	transmission security key
STO	store	TST	test
STU	secure telephone unit	UD	update
SUFY	suffix	UTIL	utility
SYNC	synchronize	VAA	vehicular amplifier adapter
TB	technical bulletin	VAR	variable
TCP	transmission control protocol	VEH	vehicular
TD	time delay	VHF	very high frequency
TDR	transportation discrepancy report	VIC	vehicular intercom set
TEK	traffic encryption key	VOL	volume
TF	tacfire of task force	WHSP	whisper
TM	technical manual	WP	way-point
TMPD	time period	XMIT	transmit
TRANS	transmission	YY	years
		z	zero

<b>GLOSSARY</b>
-----------------

**TERM****DEFINITION**

Alternate net control station	Net member operators designated by the NCS to complete net openings, respond to CUE calls, displace after using SC mode if appropriate, and take over for NCS when requested.
Automated net control device	Hand- held computer used for loading RT with COMSEC, FH data, and sync time; also replace paper SOI.
Battery life indicator	Number read from manpack RT display providing an estimate of battery power used and remaining.
Broadcast	Method of transmitting SOI information from one ANCD to another using SINCGARS data mode.
Channel	RT switch positions in which COMSEC keys and FH data, or single channel frequencies, may be loaded, stored, and used.
Cold start net opening	Method of opening a FH net in which each member loads COMSEC and FH data and stands by for receipt of sync time sent electronically by the NCS.
COMSEC keys	Traffic Encryption Key (TEK) and Key Encryption Key (KEK) required for cipher text communications and over-the-air-rekey operations.
CUE channel/frequency	SC frequency and designated channel used to contact net NCS when caller has non-FH radio or has lost contact with the FH net; may also be used as normal SC channel.
Electronic counter-countermeasures	Use of FH technique to significantly reduce the impacts of enemy jamming and avoid enemy direction finding capabilities.
Electronic remote fill (ERF)	Method by which an NCS electronically updates FH data of net members and transmits sync time for cold start net openings.
Enhanced data modes	Capabilities of the SINCGARS SIP radio in which forward error correction, speed, range, and accuracy of data transmission are materially improved. Four enhanced data rates (1200N, 2400N, 4800N, and 9600N) and two new modes (Packet and RS-232) are provided by the SIP/ASIP radio. Packet data mode can be used only with the FBCB2 system.
External (used with GRM - 122)	EXT, an option found under the RCU key of the SIP radio, represents a future capability of the radio and is not currently used. ASIP radio is in EXT mode automatically when proper interface and software is detected. When the radio is set to this mode, the front panel controls of the RT are disabled, allowing control to be performed from the peripheral device. Ensure you do not accidentally select EXT mode. <u>ICOM</u> Radio versions of the SINCGARS radio having integrated COMSEC but not equipped with SIP features. Components are identified as RT-1523, RT-1523A, RT-1523B and AM-7239, AM-7239A, AM -72398.



**TERM****DEFINITION**

FBCB2 Hardware	A term that refers to the various forms of computers used in vehicular radio configurations for data communications during army digitization experiments. FBCB2 computers range from commercial off-the-shelf items to fully militarized computers. The interface from FBCB2 computers to the SINCGARS SIP/ASIP radio system is via an RS-232 port of the computer to the SIP/ASIP VAA J6 connector.
FBCB2 Software	UNIX-based software developed especially for support of Task Force XXI operations and used in FBCB2 hardware. FBCB2 software, when employed with the SIP/ASIP RT and SIP/ASIP VAA, provides situational awareness reporting, internet operations, and SINCGARS to EPLRS automatic interface. The host interface to the SINCGARS SIP/ASIP radio system uses the commercial TCP/IP family of communications protocols specified in the Army Technical Architecture (ATA).
Frequency hopping (FH) data	Hopset, lockouts if used, TSK, net ID, and sync time required for FH communications.
FH-Master	Mode position used by the NCS in which the NCS RT helps maintain sync time in all net radios.
Holding memory	RT temporary memory used for loading, retrieving, and sending fill data.
Hot start net opening	Method of opening a FH net in which net operators load all required COMSEC, FH data, and sync time from their ANCD and merely call the NCS to check into the net.
Internet	The terms used to indicate the capability of data messages to pass automatically from one SINCGARS net to another and from a SINCGARS to an EPLRS net to reach a single addressee or broadcast sub-net. The SIP/ASIP VAA controls internet operations through the software, addresses, and routing tables stored in its memory. The internet capability is available only when the SIP/ASIP radios are employed with the FBCB2 system.
Intranet replay	The capability available when packet data mode and the FBCB2 system are used which allows a single SIP/ASIP radio to relay a data message to its addressee within the same frequency hopping net. After the transmitting station tries unsuccessfully several times to reach the addressee station, software in the SIP/ASIP VAA causes the intranet relay station to retransmit the message. The intranet feature is entirely automatic, requiring no action on the part of the intranet relay station operator. This represents a future capability and is currently not used.
Line of sight (LOS)	Straight line path between two radios that is required for best communications.
Loadset	All COMSEC keys, FH data, and sync time required to load all six RT channels for frequency hopping, cipher text mode of communications.

**TERM**

**DEFINITION**

Lockouts	Feature of hopset that precludes use of selected frequencies; also used to expand the number of frequencies contained in a hopset.
Manual channel/frequency	SC frequency and designated channel used for transmission and receipt of ERFs during cold start net openings; may also be used for normal SC channel.
Manpack radio	Configuration consisting of RT battery, battery box, antenna, handset, and carrying case; carried on the back of the operator for dismounted operations.
Net control station (NCS)	Single designated station per net requiring use of the FH-M mode position and performance of net control tasks: assisted and supported by designated alternate NCS stations as warranted by operational requirements.
Net identification (ID)	Three-digit number from 000 to 999 designating specific nets within a given TSK.
Net members	All net stations other than the NCS and designated alternate NCSs.
Offset	Feature allowing SC frequencies to be changed by plus or minus 5 or 10 KHz to reduce the effect of enemy jamming or other interference.
Over-the-air-rekey (OTAR)	Procedure by which TEK may be electronically transmitted from NCS to NCS, or from NCS to net members.
Packet	New data mode in which data messages are divided into frames smaller than 1800 bytes each for processing over SINCGARS voice/data nets. The packet data mode (PCKT) can be used only with the FBCB2 hardware and software system.
“Permanent” memory	RT random access memory (RAM) location where data is stored and used; data in “permanent memory may be retrieved if desired; retention of data in “permanent” memory depends upon main power or HUB battery.
Precision lightweight GPS receiver (PLGR)	Hand-held device providing GPS time for use as sync time in SINCGARS radios.
Primary tasks	Those operator and NCS tasks which are essential to adequate job performance.
Retransmission (RXMT)	Feature of SINCGARS radio that enables SC or FH traffic to automatically pass from one RXMT RT to another, thus increasing the effective range to that of two radios.
Scanning	Feature of SINCGARS radio that search all SC channels for traffic; cannot be used in the FH mode of operation.
Scrolling	Procedure by which a TEK may be move from one RT channel to another; does not apply to key stored in channel 6.
Single channel (SC)	Mode of communication using one designated frequency.

**TERM****DEFINITION**

System Improvement Program

Process by which army materiel managers systematically improve equipment capabilities to meet established operational requirements. The SIP/ASIP radio is a product of a SINCGARS System Improvement Program.

Special tasks

Those operator and NCS tasks which may be required in job performance; these tasks entail additional training to achieve operator proficiency.

Updating

Electronic or physical procedures by which COMSEC, FH data, and SOI information are changed; performed at prescribed intervals and as the need arises.

Vehicular radios

Radio configurations consisting of one or two RTs, mounting base, vehicular amplifier adapter, power amplifier, power amplifier adapter, power supply adapter, antennas, loudspeakers, and handsets as appropriate; these radios are installed in vehicles using specified installation kits.

Zero

Procedure by which stored data (COMSEC, FH data, sync time, and SC frequencies) may be cleared from the RT.

THIS PAGE INTENTIONALLY  
BLANK.

## I N D E X

<b><u>SUBJECT</u></b>	<b><u>PAGE</u></b>
Antennas .....	4-32
Antenna, OE-254 .....	4-34
Anti-jamming actions .....	5-69
Associated equipment maintenance .....	8-13
Automated Net Control Device (ANCD) .....	3-2
Capabilities .....	3-2
Characteristics .....	3-3
Loads and updating .....	4-23
Main power battery requirements .....	8-27
Operator controls .....	5-19
Operator maintenance .....	8-21
Physical data .....	3-3
Battery life condition indicator .....	5-64
Battery requirements .....	8-25
Battery requirements, SIP .....	2-17
Hold-Up Battery .....	2-18
HUB .....	2-17
Main power .....	2-17
Manpack radio .....	2-17
Power source .....	2-17
RCU (RT) .....	2-18
Broadcast procedure for SOI information .....	4-27
Cabling .....	2-29
Change Eset in one channel (task) .....	6-11
Change net ID (task) .....	5-60
Cipher Text (CT) operations .....	4-3
Cold Start net opening procedure .....	4-17
Common Connections .....	2-13
Common ZULU time .....	4-11
COMSEC Alarm .....	4-2
Conduct Cold Start net opening (task) .....	6-15
Conduct Hot Start net opening (task) .....	6-14
Conduct retransmission (RXMT) operations (task) .....	5-56
Connectors, ASIP RT .....	2-11
Connectors, SIP RT .....	2-10

<b><u>SUBJECT</u></b>	<b><u>PAGE</u></b>
Consolidated index of Army publications and blank forms .....	1-3
Control-Monitor (C-M) .....	2-37
Components.. .....	2-37
Operator controls .....	5-22
Performance data .....	2-38
Physical data. ....	2-38
Control, Receiver-Transmitter (RCU) .....	2-35
Components .....	2-35
Operator controls .....	5-18
Performance data. ....	2-38
Physical data. ....	2-36
Cross - net communications .....	4-12
CUE and ERF (Electronic Remote Fill) method of late net entry .....	4-21
Designate new default loadset (task) .....	6-10
Electronic updating .....	4-24
Electronic Remote Fill (ERF) procedure for FH data .....	4-26
Equipment improvement recommendations .....	1-3
Frequency hopping (FH) communications .....	4-6
Advantages .....	4-9
Capabilities .....	4-6
Data .....	4-6
Synctime .....	4-7
Frequency Hopping Multiplexer (FHMUX) .....	3-5
Components .....	3-5
Performancedata .....	3-6
Physicaldata .....	3-5
Operator maintenance .....	8-23
Tasks .....	7-17
General information .....	1-2
Hand receipt (-HR) manuals .....	1-3
Handheld Remote Control Radio Device (HRCRD) .....	3-12
HRCRD .....	3-13
Operator maintenance .....	8-24
Hot Start net opening procedure .....	4-16
Option for late net entry .....	4-19
ICOM Fill of Receiver-Transmitter (RT) .....	4-15
Integrated Communications Security (ICOM) .....	4-2

<b><u>SUBJECT</u></b>	<b><u>PAGE</u></b>
Julian Date and GPS Zulu Time .....	4-10
Jamming/anti-jamming actions .....	5-69
Late net entry (LNE), passive method .....	4-18
Load COMSEC/FH data/sync time into RT using ICOM fill procedure (task) ....	5-32
Load date and Zulu time into SINCGARS Receiver-Transmitter (RT) (task) ....	7-7
Load Precision Lightweight GPS Receiver (PLGR) key from ANCD into PLGR (task) .....	7-9
Load single channel frequencies into Receiver-Transmitter (RT) (task) .....	5-30
Loading and clearing offset frequencies .....	5-67
Loadsets .....	4-13
Long manpack antenna .....	4-32
Long Range/Long Range (LR/LR) Radio components .....	2-24
Long Range (LR) Radio components .....	2-22
Loudspeake (LS-671) .....	2-39
Components .....	2-39
Operator controls .....	5-24
Operator maintenance .....	8-20
Performance data. ....	2-40
Physicaldata .....	2-39
Maintenance forms, records, reports .....	1-2
Manpack Radio .....	2-14
Antenna, long .....	4-32
Components .....	2-14
General .....	2-14
Performancedata .....	2-16
Physical data. ....	2-15
Hold up battery (HUB) requirements .....	8-26
Main power battery requirements .....	8-25
Manually load date and Zulu time into Precision Lightweight GPS Receiver (PLGR) (task) .....	7-5
Net Control Station .....	6-3
Responsibilities .....	6-3
Tasks, general .....	6-2

<b><u>SUBJECT</u></b>	<b><u>PAGE</u></b>
Netmanagement .....	4-46
Discipline.. .....	4-46
Mobile Subscriber Equipment (MSE) compatibility .....	4-48
Operator proficiency .....	4-48
Role of Alternate NCS .....	4-47
Role of the NCS .....	4-47
Role of Signal Officers/NCOs .....	4-49
Special task performance .....	4-48
Net opening, general .....	4-13
Cold Start procedure .....	4-17
Hot Start procedure .....	4-16
Obtain date and GPS Zulu time from Precision Lightweight GPS Receiver (PLGR) (task) .....	7-4
Obtain SOI information from Automated Net Control Device (ANCD) (task) . . .	5-37
Operator .....	5-5
Controls .....	5-5
Maintenance .....	8-1
Tasks, general .....	5-2
Technical .....	5-13
Troubleshooting guides .....	8-7
Over-The-Air-Rekey (OTAR) procedures .....	4-24
Sending TEK by AK method of OTAR .....	6-26
Sending TEK by MK method of OTAR .....	6-24
Receiving TEK sent by MK method of OTAR .....	6-29
Passive method of late net entry .....	4-18
Perform Cold Start net opening (task) .....	5-51
Perform CUE and ERF (Electronic Remote Fill) late net entry method (task) ....	5-55
Pet-form Hot Start net opening (task) .....	5-34
Perform Passive Late Net Entry method (task) .....	5-36
Periodic updating .....	4-22
Of Communications Security (COMSEC) keys .....	4-22
Of Frequency Hopping (FH) data .....	4-22
Of Signal Operating Instructions (SOI) information .....	4-22
Ofsynctime .....	4-22
Precise Global Positioning System (GPS) time .....	4-11



<u>SUBJECT</u>	<u>PAGE</u>
Precision Lightweight GPS Receiver (PLGR) .....	3 - 4
Capabilities .....	3 - 4
Characteristics .....	3 - 4
Main power/HUB requirements .....	8-28
Operator controls .....	5-21
Operator maintenance .....	8-22
Physicaldata .....	3 - 4
Tasks .....	7 - 3
Tasks, definition .....	7 - 3
Tasks, summary .....	7 - 3
Preventive Maintenance Checks and Services (PMCS) .....	8 - 4
For Control-Moniotor (C-M) .....	8-17
For Remote Control Unit (RCU) .....	8-13
For SINCGARS radios .....	8 - 4
Guidance.. .....	8 - 3
Primary Net Control Station (NCS) tasks .....	6 - 6
Definition .....	6 - 6
Summary.. .....	6 - 6
Primary operator/preparation tasks .....	5-28
Definition .....	5-28
Summary.. .....	5-28
Purpose of manual .....	1 - 1
Radios, manpack .....	2-14
Radios, vehicular .....	2-19
Receive and store Traffic Encryption Key (TEK) sent by MK method of OTAR (task) .....	6-29
Receive COMSEC key/FH data into ANCD via STU (task) .....	7-13
Receive net update ERF (Electronic Remote Fill) from Net Control Station (task) .....	5-53
Receive SOI information into ANCD via Secure Telephone Unit (STU) (task) .....	7 - 16
Receiver characteristics .....	2 - 4
Receiver-Transmitter (RT) .....	2 - 2
Capabilities .....	2 - 2
Model differences .....	2 - 4
Operator controls .....	5 - 5
Physicaldata .....	2 - 6

<b><u>SUBJECT</u></b>	<b><u>PAGE</u></b>
Reloading sync time method of late net entry .....	4-20
Remote Control Unit (RCU) .....	2-35
Components .....	2-35
Hold up battery requirements .....	8-26
Main power battery requirements .....	8-25
Operator controls .....	5-18
Performancedata .....	2-36
Physical data. ....	2-36
Remoting capabilities .....	4-34
Using Control-Monitor .....	4-42
Using Loudspeaker, LS-671 .....	4-41
Using Receiver-Transmitter (RT) as RCU .....	4-40
Using Remote Control Device, C2329/GRA-39 .....	4-45
Using Remote Control Unit (RCU) .....	4-34
Using Wire Line Adapter, HYX-57 .....	4-44
Reporting equipment improvement recommendations .....	1-3
Reporting errors and recommending improvements .....	1-3
Respond to CUE calls (task) .....	6-17
Retransmission (RXMT) operations .....	4-28
Capability modes .....	4-29
General .....	4-28
Procedures .....	4-30
RT Messages .....	2-12
RT Physical Data .....	2-13
Scanning capability .....	5-68
Scope of manual .....	1-1
Scrolling communications security (COMSEC) keys .....	5-68
Secure communications .....	4-2
Secure Telephone Unit (STU) .....	3-8
Capabilities .....	3-8
Characteristics .....	3-8
Definition of tasks .....	7-11
Physicaldata .....	3-9
Summary of tasks .....	7-11
Tasks .....	7-11
Security classification and marking .....	1-3
Select RT preparation settings from MENU .....	5-29

<b><u>SUBJECT</u></b>	<b><u>PAGE</u></b>
Send COMSEC Key/FH data from ANCD to ANCD via STU (task) .....	7-12
Send data via RS-232 mode .....	5-63
Send ERF (Electronic Remote Fill) as part of retransmission (RXMT) operation (task) .....	5-58
Send SOI information from ANCD to ANCD via Secure Telephone Unit (STU) (task) .....	7-14
Send Traffic Encryption Key (TEK) to net operators using AK method of OTAR (task) .....	6-26
Send Traffic Encryption Key (TEK) to other NCSs using MK method of OTAR (task) .....	6-24
Short Range/Long Range (SR/LR) Radio components .....	2-23
Short Range/Long Range (SR/LR) Radio with dismount components .....	2-24
Short Range (SR) Radio components .....	2-21
Short Range (SR) Radio with dismount components .....	2-22
Short Range (SR) Radio with Single Radio Mount (SRM) components .....	2-32
SINCGARS associated tasks .....	7-1
SINCGARS low profile antenna (SLPA) .....	4-33
SINCGARS radio maintenance .....	8-1
SINCGARS Receiver-Transmitter (RT) .....	2-2
Single channel (SC) communications .....	4-4
Capabilities .....	4-4
Limitations .....	4-5
Required usage .....	4-5
Single Radio Mount (SRM) Radio .....	2-32
Perfomancedata .....	2-34
Physicaldata .....	2-33
SIP/ASIP Receiver-Transmitter .....	2-8
SIP/ASIP RT Keypad .....	2-8
SIP/ASIP VAA .....	2-9
Special Net Control Station (NCS) tasks .....	6-18
Definition of tasks .....	6-18
Summary of tasks .....	6-18
Special operator tasks .....	5-42
Definition of tasks .....	5-42
Summary of tasks .....	5-43
Special operator tasks (SIP/ASIP) .....	5-62
Start-up procedure .....	5-3

<b><u>SUBJECT</u></b>	<b><u>PAGE</u></b>
Technical .....	2 - 8
Traffic Encryption Key (TEK) .....	4 - 3
Transfer COMSEC/FH data from ANCD to ANCD (task) .....	5-45
Transfer COMSEC key from ANCD to RT (task) .....	6 - 9
Transfer full SOI information from ANCD to ANCD (task) .....	5-49
Transfer partial COMSEC/FH data from ANCD to ANCD (task) .....	6 - 7
Transfer Quick Reference (QREF) SOI information from ANCD to ANCD (task) .	5-47
Transfer selected SOI information from ANCD to ANCD (task) .....	6 - 12
Transmit SOI information using Broadcast mode (task) .....	6-21
Transmit updated FH data via net update ERF (Electronic Remote Fill) (task) . .	6-19
Transmitter characteristics .....	2 - 3
Two-digit Julian date .....	4 - 10
Use SIP/ASIP RT as an RCU .....	5-62
VAA Connectors (A/B models) .....	2-25
VAA Connectors (C/D models) .....	2-27
Vehicular Intercom set (VIC) .....	3-10
Capabilities .....	3-10
Characteristics .....	3-10
Operator controls .....	5-25
Operator maintenance .....	8-18
Physical data. ....	3-11
Vehicular (Veh) radios .....	2-19
Performance data. ....	2-31
Physical data. ....	2-30
Zulutime.. .....	4-10



THEN ... JOT DOWN THE DOPE ABOUT IT ON THIS FORM. CAREFULLY TEAR IT OUT. FOLD IT AND DROP IT IN THE MAIL.

# SOMETHING WRONG WITH THIS PUBLICATION

FROM: (PRINT YOUR UNIT'S COMPLETE ADDRESS)  
 Commander  
 Stateside Army Depot  
 ATTN: AMSTA-US  
 Stateside, N.J. 07703-5007

DATE SENT  
 10 July 1975

PUBLICATION NUMBER TM 11-5820-890-10-8	PUBLICATION DATE 23 Jan 74	PUBLICATION TITLE Radar Set AN/PRC-76
---	-------------------------------	--

BE EXACT PIN-POINT WHERE IT IS				IN THIS SPACE TELL WHAT IS WRONG AND WHAT SHOULD BE DONE ABOUT IT:
PAGE NO	PARA-GRAPH	FIGURE NO	TABLE NO	
2-25	2-28			<p>Recommend that the installation antenna alignment procedure be changed throughout to specify a 2° IFF antenna lag rather than 1°.</p> <p>REASON: Experience has shown that with only a 1° lag, the antenna servo system is too sensitive to wind gusting in excess of 25 knots, and has a tendency to rapidly accelerate and decelerate at gusts, causing strain to the drive train. Hunting is minimized by adjusting the lag to 2° without degradation of operation.</p>
3-10	3-3		3-1	<p>Item 5, Functional Column. Change "2 dB" to "3 dB".</p> <p>REASON: The adjustment procedure for the TRANS POWER FAULT indicator calls for a 3 dB (500 watts) adjustment to light TRANS POWER FAULT indicator.</p>
5-6	5-8			<p>and new step f.1 to read, "Replace cover plate removed in step above."</p> <p>REASON: To replace the cover plate.</p>
		FO-3		<p>Zone C 3. On J1-2, change "+24 VDC" to "+5 VDC".</p> <p>REASON: This is the output line of the 5 VDC power supply. +24 VDC is the input voltage.</p>

TEAR ALONG DOTTED LINE

SAMPLE

PRINTED NAME, GRADE OR TITLE AND TELEPHONE NUMBER SSG I. M. DeSpiritof 999-1776	SIGN HERE 
--	---------------

FILL IN YOUR  
UNIT'S ADDRESS

FOLD BACK

DEPARTMENT OF THE ARMY

\_\_\_\_\_  
\_\_\_\_\_

OFFICIAL BUSINESS



TEAR ALONG DOTTED LINE

U.S. Army  
ATTN: AMSE  
Fort Monmouth, New Jersey 07703-5007

**SAMPLE**



FILL IN YOUR  
UNIT'S ADDRESS

FOLD BACK

DEPARTMENT OF THE ARMY



OFFICIAL BUSINESS



TEAR ALONG DOTTED LINE

**U.S. Army CECOM  
ATTN: AMSEL-LC-LM-LT  
Fort Monmouth, New Jersey 07703-5007**



# SOMETHING WRONG WITH THIS PUBLICATION



THEN ... JOT DOWN THE DOPE ABOUT IT ON THIS FORM. CAREFULLY TEAR IT OUT. FOLD IT AND DROP IT IN THE MAIL.

FROM: (PRINT YOUR UNIT'S COMPLETE ADDRESS)

DATE SENT

PUBLICATION NUMBER

TM 11-5820-890-10-8

PUBLICATION DATE

1 December 1998

PUBLICATION TITLE

OPERATOR'S MANUAL; SINGGARS  
GROUND COMBAT NET RADIO, ICOM

BE EXACT PIN-POINT WHERE IT IS

IN THIS SPACE TELL WHAT IS WRONG  
AND WHAT SHOULD BE DONE ABOUT IT:

PAGE  
NO

PARA-  
GRAPH

FIGURE  
NO

TABLE  
NO

TEAR, .G DOTTED LINE.

PRINTED NAME, GRADE OR TITLE AND TELEPHONE NUMBER

SIGN HERE

FILL IN YOUR  
UNIT'S ADDRESS

FOLD BACK

DEPARTMENT OF THE ARMY



OFFICIAL BUSINESS



TEAR ALONG DOTTED LINE

**U.S. Army CECOM  
ATTN: AMSEL-LC-LM-LT  
Fort Monmouth, New Jersey 07703-5007**



FILL IN YOUR  
UNIT'S ADDRESS

FOLD BACK

DEPARTMENT OF THE ARMY



OFFICIAL BUSINESS



TEAR ALONG DOTTED LINE

**U.S. Army CECOM  
ATTN: AMSEL-LC-LM-LT  
Fort Monmouth, New Jersey 07703-5007**

By Order of the Secretary of the Army:

Official:

  
JOEL B. HUDSON  
*Administrative Assistant to the  
Secretary of the Army*  
05842

DENNIS J. REIMER  
*General, United States Army*  
Chief of Staff

DISTRIBUTION:

To be distributed in accordance with the initial distribution number (IDN) 369784 requirements for TM 11-5820-890-10-8.

☆ U.S. GOVERNMENT PRINTING OFFICE: 1999-710-117/80152





